

4995-1
OWNER'S MANUAL
4995

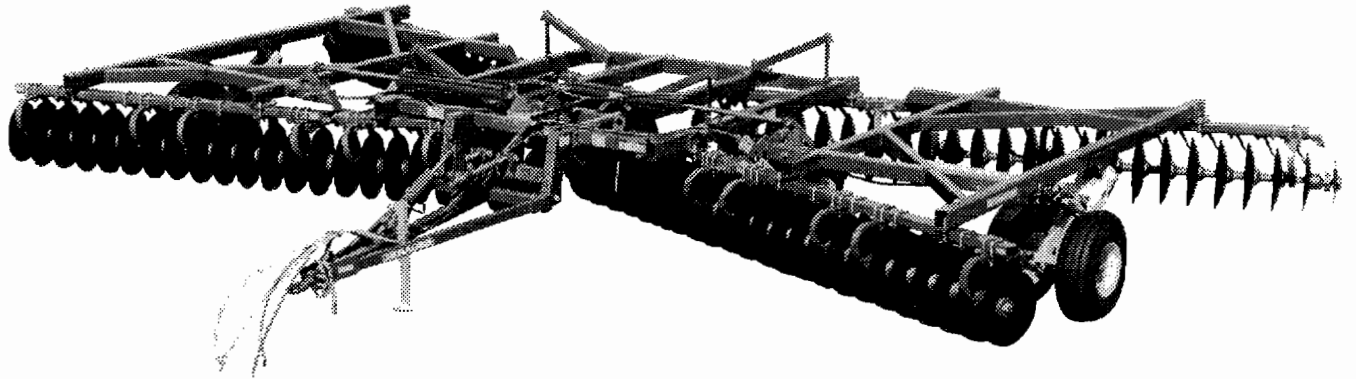

FLEX-WING TANDEM DISC HARROW

4995 SERIES

KRAUSE

P.O. BOX 2707, 305 SOUTH MONROE STREET HUTCHINSON, KANSAS 67504-2707



A note to our customers, parts managers and dealers:

This manual has been prepared to assist you in the proper use, daily care, and operation of your new Krause equipment. It contains specific information on the many built-in features of your equipment, the accessories and options that are available, general specifications, and instructions for making minor adjustments.

Read this manual carefully before operating your Krause equipment, and keep it in a convenient location for later reference.

In order to ensure that you have the most current owner's manual available for your implement, we have added a revision code to each manual. Please note the information listed below and specify when placing service calls or ordering parts.

Manual for Model: 4995

This manual covers models beginning with Serial No. 1026

Owner's Manual #: 4995-1A

Parts Manual #: 4995-2A

Rev.: A

ISSUED TO:

ISSUED BY:

Owner's Name

Krause Dealer

Mailing Address

City

City

State

State

Date of Purchase

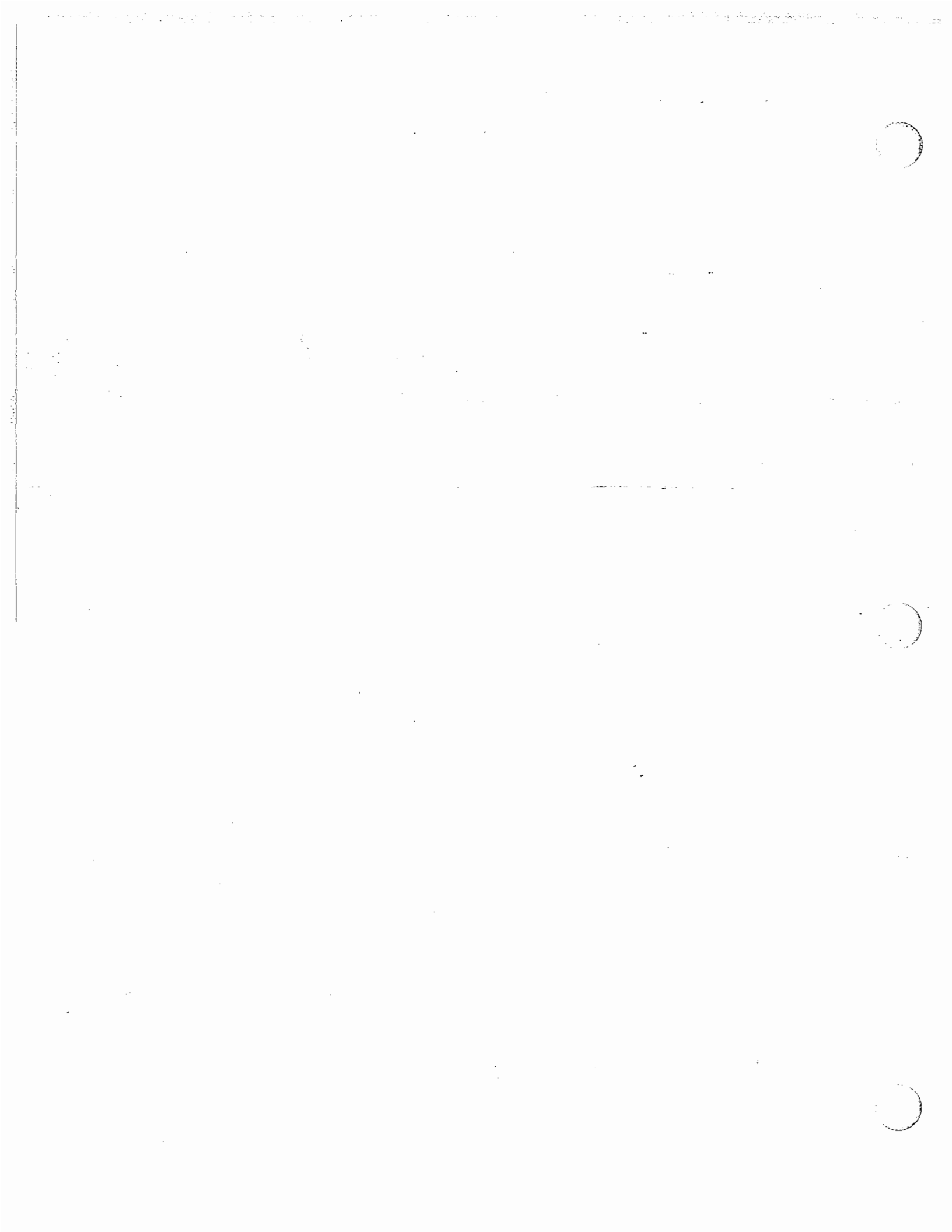

Warranty Policy

(Krause Serial Numbered Wholegoods purchased subsequent to 7/1/99)

Note: All warranty work must be accomplished by a Krause Corporation Authorized Service Center rated to perform maintenance on Krause Corporation Products.

A. KRAUSE CORPORATION ("KRAUSE") LIMITED WARRANTY.

- (1) Subject to the limitations and conditions hereinafter set forth, Krause warrants, at the time of delivery by Krause to be free from (i) defects in materials or workmanship, and (ii) defects in design that in the view of the state of the art as of the date of manufacture should have been foreseen provided, however, that the defect must be discovered and reported to Krause within the periods specified as follows. For a period of one year all new serial numbered production agricultural units covered by this warranty; for a period of thirty-six (36) months the tongue weldment, center frame weldment, wing frame weldments, disc harrow gang bearings and K-Tine field cultivator shanks.
 - (2) Krause does not warrant disc blades, shanks, hydraulic cylinders, accessories and other parts not manufactured by it, but supplied with or as a part of its products. Krause will, however, obtain and pass on any adjustments provided by the manufacturers of such parts under these manufacturer's warranties. Tires supplied on Krause products, will be warranted by the tire manufacturer's retail outlets.
 - (3) The entire extent of Krause's liability shall be limited to that of either reimbursing Buyer for its costs of purchasing a rebuilt, over-hauled or repaired part from either Krause or a proper Krause Authorized Service Center or, at Krause's election, reimbursing buyer for its costs of having the part repaired at a proper Krause Authorized Service Center. If Krause elects not to repair the part and if neither a rebuilt, over-hauled or repaired part is, in Krause's opinion, timely available then Krause will reimburse buyer for its costs of purchasing a new part from either Krause or a proper Krause Authorized Service Center. The labor necessary to remove from the product such part or parts and to install in the product such part or parts, as well as any repair made as the result of improper installations by Krause, shall be covered by this warranty, provided the work is performed at a proper Krause Authorized Service Center.* If return of the defective part is required, it must be returned shipping prepaid to Krause. Krause's limited warranty will apply to any part repaired or replaced by a proper Krause Authorized Service Center pursuant to Krause's Limited Warranty: however, the applicable warranty for such part repaired or replaced shall be limited to the unexpired portion of Krause's Limited Warranty described in paragraph (1) or (2) above, as applicable. In other words, the warranty period of the part repaired or replaced does not start over from the date of reinstallation.
- *[Krause Corporation will repair or replace, free of charge, any part of the product found to be defective, within the specified warranty periods, after an inspection of the part has deemed it to be defective. Inspection must be performed by an authorized agent of Krause Corporation, or returned to the Krause factory for inspection and disposition. Warranty labor will be considered during the first year of warranty only. Krause Corporation will establish and publish an hourly flat rate for shop labor and reimbursement during the first year of the warranty period. Krause Corporation does not allow credit for the cost of travel time, mileage or hauling as a warranty allowance. During the remaining second and third year, when applicable, Krause will repair or replace the defective part, without consideration of labor charges.]
- (4) Routine services (such as inspections, field settings, adjustments, etc.) and replacement of items which deteriorate from expected normal wear and tear or exposure (such as paint, tires, hoses, blades, sweeps, etc.) are not covered by this Limited Warranty. Such routine services and replacements required during the course of operation are not considered to be the result of any defect in the product.

B. LIMITATIONS APPLICABLE TO KRAUSE'S LIMITED WARRANTY.

- (1) Krause will be relieved of all obligations and liability under this warranty if:
 - (i) The alleged defect in the part is due to misuse or neglect on the part of someone other than Krause;
or
 - (ii) Krause's identification mark or name or serial number has been removed from the part in question;
or
 - (iii) The product and/or equipment have not been maintained, operated or stored either in accordance with applicable manuals, communications or other written instructions of Krause or any manufacturer of the part involved, or in accordance with applicable regulations and advisory circulars unless buyer shows that such maintenance, operation or storage was not a contributory cause of the defect; or
 - (iv) The part in question has been modified or altered after delivery other than by the manufacturer or in accordance with a modification or alternation scheme approved in writing by the manufacturer; or
 - (v) The product is used for purposes other than conventional owner/operator usage. Usage not considered conventional owner/operator includes, but is not limited to, operation conditions that consist of rocks or other obstructions.
- (2) For the purpose of this Warranty, no part of the product or equipment will be regarded as breaching the limited warranty merely because, subsequent to its delivery, some modification or alteration becomes necessary for product improvements or in order to meet a change in the requirements of any applicable regulation.
- (3) TO THE EXTENT ALLOWED BY APPLICABLE LAW, BUYER WAIVES AS TO KRAUSE ALL OTHER WARRANTIES, WHETHER OF MERCHANTABILITY, FITNESS OR OTHERWISE, THERE ARE NO WARRANTIES WHICH EXTEND BEYOND THE DESCRIPTION ON THE FACT HEREOF.
- (4) TO THE EXTENT ALLOWED BY APPLICABLE LAW, THE OBLIGATIONS OF KRAUSE SET FORTH HEREIN SHALL BE THE EXCLUSIVE REMEDIES FOR ANY BREACH OF WARRANTY HEREUNDER, AND, TO THE SAME EXTENT, KRAUSE SHALL NOT BE LIABLE FOR ANY GENERAL, CONSEQUENTIAL OR INCIDENTAL DAMAGES, INCLUDING, WITHOUT LIMITATION, ANY DAMAGES FOR DIMINUTION OF MARKET VALUE, LOSS OF USE OR LOSS OF PROFITS, OR ANY DAMAGES TO THE PRODUCT CLAIMED BY BUYER OR ANY OTHER PERSON OR ENTITY UPON THE THEORIES OF NEGLIGENCE OR STRICT LIABILITY IN TORT.
- (5) ANY ACTION BY BUYER FOR BREACH OF THIS WARRANTY BY EITHER KRAUSE OR SELLER MUST BE COMMENCED WITHIN (1) YEAR AFTER THE CAUSE OF ACTION ACCRUES.

Establishing Customer Warranty

Dealer's Obligation

1. It is the responsibility of the dealer to complete a **Delivery Report and Warranty Registration** form. The form should contain the model, serial number, delivery date, along with the complete dealer and customer address. This form must be signed by the dealer and customer upon physical delivery of the product to the customer. The dealer must complete the **pre-delivery check list** provided on the Delivery Report and Warranty Registration form.
2. Dealer will review the **Predelivery Check List** located in the front of the owner's manual with the customer and / or operator. This should be signed by the dealer at time of delivery to the retail customer.
3. The dealer will review the **Customer Review Sheet** located at the front of the owner's manual with the customer and / or operator. This should be signed by the dealer representative and the customer.
4. An authorized Krause dealer will submit **warranty claims** on behalf of the customer. All claims must be handled through the dealer. They will then be given to the Krause District Manager for inspection and approval. Warranty requests must be filed within 60 days from completion of the repair for consideration.
5. It is the dealer's responsibility to **service** the warranty on products sold through said dealership.

This warranty gives you specific rights, and you may also have other rights which vary from state to state.

4995 SERIES WING TANDEM DISC HARROW CUSTOMER REVIEW SHEET

CUSTOMER _____ DATE _____

ADDRESS _____

DEALER _____

ADDRESS _____

MODEL _____ SERIAL NUMBER _____

1. ___ Owner's manual provided.
2. ___ Warranty card filled out and mailed.
3. ___ Review safety warnings and cautions as listed in this owner's manual.
4. ___ Review recommended maximum road speed, width, and height for this implement.
5. ___ Review field operation speeds, horsepower, depth and rock conditions.
6. ___ Demonstrate the proper use of the road lock valve and wing lock pins.
7. ___ Explain the hydraulic depth control system (See page O8 in this manual).
8. ___ Review limitations of additional weight and transport speed when adding attachments.
9. ___ Explain the importance of maintaining the tool through lubrication, checking that bolts are kept tight, and replacement of worn or broken parts.
10. ___ Recommend that a safety chain be used with the implement.
11. ___ Check wheel lug bolts frequently until they become set.
12. ___ Explain lighting requirements for your area.

DEALER _____ DATE _____

CUSTOMER _____ DATE _____

Table of Contents

Rev.3/00

WARRANTY			
DEALER PREDELIVERY CHECK SHEET	1	MAIN ROCKER ASSEMBLY	P9
CUSTOMER REVIEW SHEET	2	WING ROCKER ASSEMBLY	P11
TABLE OF CONTENTS	3	CENTER SECTION WALKING BEAM	P12
SPECIFICATIONS	4	WING SECTION WALKING BEAM	P13
GENERAL INFORMATION DRAWING	5	WING HUB ASSEMBLY	P14
SAFETY DECALS	6	DISC BLADES, WHEELS & TIRES	P15
OPERATION SECTION		SPACER SPOOLS	P16
SAFETY FIRST	01	TIE RODS	P17
ABOUT YOUR TANDEM DISC	02	ROCK FLEX BEARING ARM ASSEMBLY	P18-P19
PREPARING FOR OPERATION	02	RIGID SCRAPERS	P20
PREPARING THE TRACTOR	03	EXTENSION TRASH BAR ASSEMBLIES	P21
HYDRAULIC SYSTEM	03	SPRING LOADED SCRAPER ASSEMBLY	P23
HITCHING & UNHITCHING	03	DOUBLE SCRAPER ASSEMBLY	P24
Hitching To The Tractor	03	TRAIL HITCH ASSEMBLY	P25
Unhitching From The Tractor	04	PACKER HITCH	P26
TRANSPORTING	04	GAUGE WHEEL ASSEMBLY - ACCESSORY	P27
Transport Lock Valve	04	HYDRAULIC HOSE W/PLASTIC HANDLE GRIPS	P28
Raising The Wings	05	Wing Lift Hydraulics	P29
Lowering The Wings	05	Depth Control Hydraulics (Series)	P31
Transport Safety	05	Optional Hose Kit (Tongue Plumbed w/3rd Tractor Coupler)	P33
Hitch Pin	06	Eaton Hydraulic Cylinders:	
FIELD ADJUSTMENTS	06	3-3/4" Prince Series Cylinder Assembly	P34
Front to Rear Leveling	06	4" x 8" Prince Series Cylinder Assembly	P35
Center Rocker Timing Link	07	4-1/4" x 8" Prince Series Cylinder Assembly	P36
Leveling The Wings	07	Prince 3" x 8" Tongue Cylinder Assembly	P37
Hydraulic Depth Control Adjustment	08	Prince 4-1/2" x 40" Wing Lift Cylinder Assembly	P38
UNDERSTANDING YOUR DEPTH CONTROL SYSTEM	08	DECALS & REFLECTORS	P39
Rigid Scraper Adjustment	09	LIGHT KIT ACCESSORY	P40
Spring Loaded Scraper Adjustment	09	ASSEMBLY SECTION	
FIELD OPERATION	010	GENERAL INFORMATION PHOTOGRAPH	A2
Working Depth	010	SAFETY & ASSEMBLY AREA INFORMATION	A3
Flexibility	010	PART LOCATIONS	A3
Turning In The Field	010	MODEL NUMBERS	A3
General Information	011	CENTER FRAME HALVES	A4
STORAGE SUGGESTIONS	011	TONGUE ASSEMBLY	A5
SERVICING	011	CENTER ROCKER ASSEMBLY	A8
General Maintenance	011	CENTER GANG ATTACHMENT	A9
Lubrication	011	WING FRAME ASSEMBLY	A13
Wheel Bearings	011	WING ROCKER ASSEMBLY	A16
Disc Gangs	012	DEPTH STOP LINKAGE	A18
Repair Parts	012	HYDRAULICS ASSEMBLY	A18
Hydraulics	013	DECAL ATTACHMENT	A24
Avoid Heating Near Pressurized Fluid Lines	013	FINAL CHECK	A24
HYDRAULIC SUGGESTED REMEDIES SECTION	014	LIGHT KIT ASSEMBLY INSTRUCTION SHEET	A25
TESTING FOR INTERNAL HYDRAULIC LEAKS	014 - 017	MODELS 4995-28N & 4995-28NR PLACEMENT	A27
Case 1 & Case 2	015	MODELS 4995-28W & 4995-28WR PLACEMENT	A29
Case 3 & Case 4	016	MODELS 4995-28W & 4995-28WR PLACEMENT	A31
Case 5 & Case 6	017	MODELS 4995-31N & 4995-31NR PLACEMENT	A33
SUGGESTED REMEDIES FOR FIELD PROBLEMS	018-019	MODELS 4995-31W & 4995-31WR PLACEMENT	A35
		MODELS 4995-31W & 4995-31WR PLACEMENT	A37
		MODELS 4995-34N & 4995-34NR PLACEMENT	A39
		MODELS 4995-34W & 4995-34WR PLACEMENT	A41
		MODELS 4995-34W & 4995-34WR PLACEMENT	A43
		MODELS 4995-36W & 4995-36WR PLACEMENT	A45
		MODELS 4995-36W & 4995-36WR PLACEMENT	A47
PARTS SECTION			
MAIN FRAME & GANG BEAM ASSEMBLY	P3		
TONGUE ASSEMBLY	P5		
WING FRAMES & GANG BEAMS	P7		

4995 SPECIFICATIONS

RIGID MODELS								9/99
MODEL	TOTAL NO. OF DISC BLADES INCLUDING EXTENSIONS	SPACING	DISC BLADE SIZE	ASAE CUT WIDTH	CENTER SECTION CUT WIDTH	WING SECTION CUT WIDTH	WHEEL SPACING CENTER SECTION	WHEEL SPACING WING SECTION
4995-28W	78	9-1/8"	22"/24"	28' 2"	12' 4"	7' 11"	82/136	246/303
4995-28N	86	8"	22"	27' 6"	12' 4"	7' 7"	82/136	246/303
4995-31W	86	9-1/8"	22"/24"	31' 1"	12' 4"	9' 5"	82/136	282/341
4995-31N	94	8"	22"	30' 0"	12' 4"	8' 10"	82/136	282/341
4995-34W	94	9-1/8"	22"/24"	33' 11"	12' 4"	10' 10"	82/136	307/364
4995-34N	106	8"	22"	33' 10"	12' 4"	10' 9"	82/136	307/364
4995-36W	98	9-1/8"	22"/24"	35' 5"	12' 4"	11' 7"	82/136	307/364
ROCK FLEX MODELS								
4995-28WR	78	9-1/8"	22"/24"	28' 2"	12' 4"	7' 11"	82/136	246/303
4995-28NR	86	8"	22"	27' 6"	12' 4"	7' 7"	82/136	246/303
4995-31WR	86	9-1/8"	22"/24"	31' 1"	12' 4"	9' 5"	82/136	282/341
4995-31NR	94	8"	22"	30' 0"	12' 4"	8' 10"	82/136	282/341
4995-34WR	94	9-1/8"	22"/24"	33' 11"	12' 4"	10' 10"	82/136	307/364
4995-34NR	106	8"	22"	33' 10"	12' 4"	10' 9"	82/136	307/364
4995-36WR	98	9-1/8"	22"/24"	35' 5"	12' 4"	11' 7"	82/136	307/364

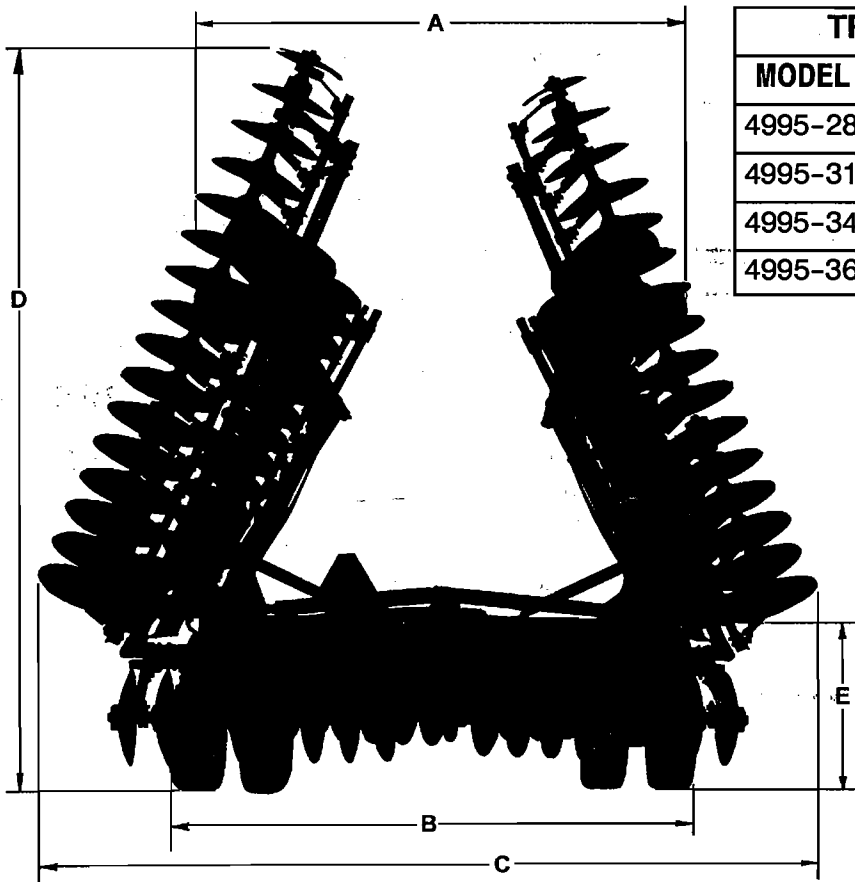

TRANSPORT INFORMATION					
MODEL	A	B	C	D	E
4995-28	13' 0"	11' 9"	16' 2"	12' 0"	3' 0"
4995-31	11' 6"	11' 9"	16' 2"	13' 6"	3' 0"
4995-34	11' 6"	11' 9"	16' 2"	15' 0"	3' 0"
4995-36	11' 6"	11' 9"	16' 2"	15' 9"	3' 0"

NOTE: Addition of tine or spike attachments may increase overall transport width and height of the implement.

G E N E R A L I N F O R M A T I O N

 READ ALL SAFETY DECALS ON THE UNIT AND READ ALL SAFETY INSTRUCTIONS ON THE BACK COVER AND THROUGHOUT THE BOOK

 IMPORTANT: GREASE THESE LOCATIONS AFTER EVERY 24 HOURS OF USE.

READ OPERATING INSTRUCTIONS IN THIS BOOK FOR DETAILED INFORMATION

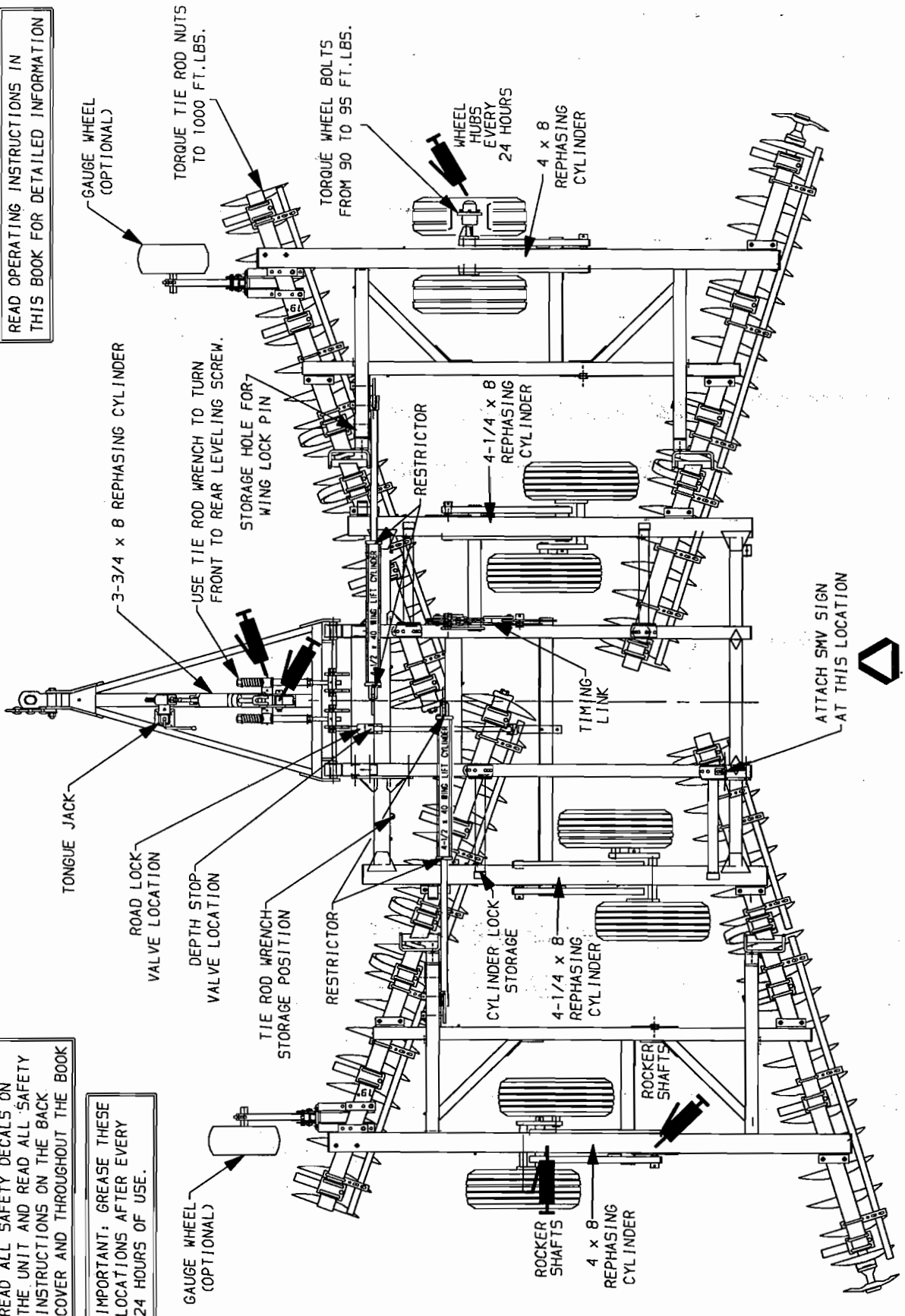

SAFETY DECALS

⚠ CAUTION

READ AND UNDERSTAND YOUR OPERATOR'S MANUAL. OBSERVE ALL CAUTION, WARNING &/OR DANGER INSTRUCTIONS AND OTHER SAFETY PRACTICES

1. Stop tractor engine and set hand brake before working on or under implement.
2. Do not allow anyone to ride on implement. Do not allow anyone on tractor except operator.
3. Make certain that everyone is clear before moving implement or activating any controls that may cause movement of implement, hydraulics, or any components.
4. Operate with increased caution on slopes and near ditches where there is a possibility that the tractor or implement could overturn.
5. Before transporting, install wing locks, transport locks, and safety chain. The towing vehicle must weigh more than the implement.
6. Before transporting, clean off reflectors and make certain SMV emblem is clearly visible.
7. Maximum transport speed is 15 MPH on best road surface.
8. Store with wings and implement on ground.
9. Lower wings when working on or around implement.
10. Regularly inspect bolts & pins in hitch, wheel hubs, cylinders & transport locks.

FAILURE TO OBSERVE SAFETY INSTRUCTIONS AND SAFETY PRACTICES CAN CAUSE PROPERTY DAMAGE, SERIOUS BODILY INJURY, &/OR DEATH.

74-117

⚠ WARNING

Escaping fluid under pressure can penetrate the skin causing serious injury. Avoid the hazard by relieving pressure before disconnecting hydraulic lines. Tighten all connections before applying pressure.

Search for leaks with a piece of cardboard. Protect hands and body from high pressure fluids.

If an accident occurs, see a doctor immediately. Any fluid injected into the skin must be surgically removed within a few hours or gangrene may result.



INSPECT the hose assembly before each use.

REPLACE the hose assembly immediately if:

- A. The jacket of the hose appears abnormal.
- B. You have reason to believe it may be abnormal.
- C. There is any fluid leakage.
- D. The couplings are damaged.
- E. The hose is damaged or kinked.
- F. The reinforcement is visible through the jacket.

74-276

⚠ WARNING



CONTACT WITH A POWER LINE OR OTHER OBSTRUCTION CAN CAUSE DAMAGE, SERIOUS BODILY INJURY OR DEATH.

BE AWARE OF THE IMPLEMENT TRANSPORT WIDTH AND HEIGHT. WATCH WIDTH AND HEIGHT CLEARANCES WHEN MOVING THE IMPLEMENT.

HARROW ATTACHMENTS WILL ADD TO TRANSPORT HEIGHT AND WIDTH. FOR YOUR SAFETY, MEASURE OVERALL WIDTH AND HEIGHT OF THE IMPLEMENT AFTER INSTALLING HARROWS OR ANY OTHER ATTACHMENT TO THE IMPLEMENT.

74-121

⚠ WARNING

CYLINDERS MUST BE CHARGED WITH OIL BEFORE IMPLEMENT OR WINGS ARE LOWERED. LOWERING WITHOUT PURGING ALL AIR FROM THE HYDRAULIC CYLINDERS MAY RESULT IN PERMANENT AND EXTENSIVE DAMAGE.

1. Remove rod end pins from cylinders.
2. Block up rod end of cylinder to allow freedom of movement while extending and retracting cylinder rod.
3. Cycle cylinder sufficient times to remove all air.
4. Reconnect cylinder rod end pin.

74-113

⚠ WARNING



FAILURE OF HYDRAULIC COMPONENTS OR ACCIDENTAL OPERATION OF HYDRAULIC CONTROLS CAN ALLOW IMPLEMENTS OR WINGS TO FALL AND CAUSE SERIOUS BODILY INJURY OR DEATH!

1. Keep everyone clear when raising or lowering implement.
2. Install all transport lock pins when working on or under implement.
3. Check for adequate overhead and side-to-side clearance before raising or lowering wings.
4. Make certain all hydraulic systems are full of oil and free of air before raising or lowering wings or implement. Check operator's manual for detailed instructions.

74-102

74-108 RED REFLECTOR

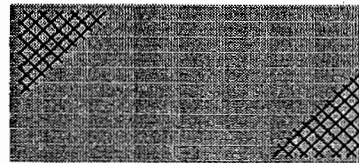

74-107 AMBER REFLECTOR

⚠ WARNING



PINCH POINT

STAY CLEAR OF THIS AREA!

SERIOUS PERSONAL INJURY MAY OCCUR.

74-349

⚠ WARNING

TO AVOID INJURY CLOSE LOCK VALVE BEFORE TRANSPORTING OR SERVICING MACHINE.

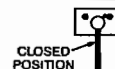

74-384

⚠ WARNING

TO AVOID INJURY DURING ASSEMBLY OR MAINTENANCE, INSTALL LOCK CHANNEL(S) OVER EXTENDED CENTER CYLINDER ROD(S).



74-387

See page P39 in this manual for proper location of decals.

OPERATING SECTION

OPERATING INSTRUCTIONS

Elimination of the hazards listed in this manual should not be construed as providing guarantees that the equipment will meet or exceed all standards or regulations, or will be completely safe to all personnel. The operator should inspect and review the implement after it is in his possession for adequacy in safety for the function for which it will be used.



READ ALL THE SAFETY DECALS ON THE IMPLEMENT AND REVIEW THE SAFETY FIRST SUGGESTIONS ON THE BACK OF THIS MANUAL TO REFRESH YOUR MEMORY. WATCH FOR THE SAFETY SYMBOL, AND READ THE INFORMATION THAT FOLLOWS. THIS IS FOR YOUR OWN PROTECTION.

ABOUT YOUR TANDEM DISC

This tandem disc was designed for medium primary to finish work and can be pulled over a wide range of field speeds ranging from 3.5 to 6 m.p.h., with maximum working depth under normal conditions of 6.5 inches. Do not exceed 5 m.p.h. in rocky conditions.

Horsepower requirements will be about 6 HP per foot of cut in average soil conditions. See your Krause dealer about a "DISC HARROW SELECTION GUIDE" for additional information.

Adding attachments should be limited to KRAUSE original equipment options, or light duty tine or spike harrows that weigh no more than 30 pounds per foot of cut width. Additions of harrows will make the disc "tail heavy" and the tongue jack must then be moved to the rear when the disc is parked or stored. (See "Hitching and Unhitching")

PREPARING THE TANDEM DISC FOR OPERATION



Caution: Lower implement to the ground before making the following inspections. If implement is not lowered, any hydraulic failure could cause the unit to drop suddenly, causing personal injury.

1. Inspect for any loose bolts.
2. Check disc gangs for tight tie rod nuts and clinched cotter pins.
3. Look at the top of each bearing arm and check to see if it is flush with the bottom of the frames. See page O12 "DISC GANGS".
4. Check tire pressure. Inflate 10.00 x 15, 8-Ply tires to 40 PSI.



Caution: Frequently check to see that the wheel lug bolts are torqued 90 to 95 Ft. Lbs. The bolts may work loose, resulting in the loss of a wheel and subsequent loss of control of the tool and/or tractor. Check again after the first 1/2 mile of initial transport.

5. Make sure that all grease zerks locations have been sufficiently greased. Grease zerks will be found on rocker shaft bearings, regreaseable disc gang bearings, adjustment screws, and wheel hubs. USE EXTREME CAUTION WHEN WORKING AROUND DISC BLADES.

6. Check and adjust tightness of wheel bearings before operation, after the first week and periodically thereafter. (See Service Section of this manual)

PREPARING THE TRACTOR

Read your tractor owner's manual. It will describe safe methods of operation. Make sure your tractor has proper added ballast, and that its hydraulic system is full of oil and working properly. Check tractor brakes and warning lights, make sure they are in working order.

HYDRAULIC SYSTEM

Inspect the hydraulic system for tell-tale leaks and loose fittings. Tighten if needed. When assembling your hydraulic system, the JIC and O-Ring fittings and hoses do not require tape or liquid sealers. **MAKE SURE** a restrictor (YELLOW COLOR) is installed in all wing lift cylinder ports. If not previously filled, your hydraulic system will require 40 quarts of your tractor manufacturer's recommended oil. Read the Service Section of your tractor owner's manual for identification of the manufacturer's recommended oil. Read the Service Section "HYDRAULICS" on page O13 before filling your hydraulic system.

When working with rephasing rocker cylinders, be sure all of the cylinders are mounted in proper sequence. Hoses must be attached in the proper order, and all air bled from the hoses and cylinders. See pages O13 under HYDRAULICS. If after some time, one cylinder of the series should start to close for no apparent reason, oil is probably leaking past the O-Ring and an O-Ring kit should be installed by a Krause Dealer.

REPAIR OF HYDRAULIC CYLINDERS SHOULD BE MADE BY AN AUTHORIZED KRAUSE DEALER ONLY.

HYDRAULIC HOSE AND CYLINDER DRAWINGS CAN FOUND ON PAGES P29 THROUGH P33 OF THE PARTS SECTION IN THIS MANUAL.

⚠ Caution: Air in hydraulic system could allow disc harrow or wings to drop suddenly.

Do not operate the wing hydraulics until you have read wing lift and lock operating instructions under "Transporting".

HITCHING & UNHITCHING

⚠ Danger: Do not allow any person to stand between the tractor and implement while backing into position. Sudden loss of control could cause serious injury or death to a person caught between the tractor and implement. Tell your helper to wait until you give him the signal that the tractor is in park or neutral and the hand brake is set and engine is shut off.

Hitching To The Tractor

1. The disc should be supported by the tongue jack.
2. Unpin tractor drawbar so it can be moved from side to side.

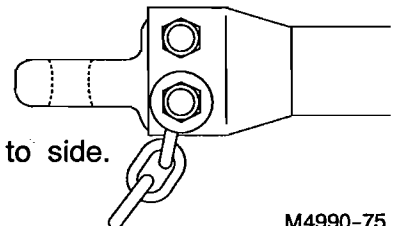

3. Back the tractor to the disc harrow.
4. Attach clevis to tractor drawbar with a clevis pin that fits the hole size in the tractor drawbar. Make sure the clevis pin is locked or bolted in place to prevent loss.

Unhitching From The Tractor

If the disc is not be used for the remainder of the day, select a good parking place that will permit the lowering of the wings. The disc should be parked in the storage position with the wings down and the road lock valve closed. If the disc is to remain parked for storage over a long period of time, be sure to read the storage suggestions on page O11.

1. To unhitch the tractor from the disc, place the tractor in park or neutral and set the hand brake. Always block the implement tires to prevent damage to the jack.
2. Have all personnel stand clear and lower the wings.
3. Turn off tractor power and relieve any hydraulic pressure that might be in the system by moving the tractor control lever(s) back and forth.

Lower tongue jack, raise the tongue height until the clevis pin can be removed.

NOTE: If rear attachments have been added, and the disc is tail heavy, move the tongue jack to the mounting tube located at the back of the main frame.

4. Disconnect the hydraulic hoses, and the tractor may be moved away.

⚠ Caution: Do not stand on or straddle the tongue when unhitching. If rear attachments have been added to the rear of the implement, it may affect the balance of the implement, causing the tongue to raise up suddenly when unhitching.

TRANSPORTING

Check specifications page and be aware of the transport height and width of your model of disc.

⚠ Warning: Always close transport lock valve and insert wing lock pins when transporting to prevent unit from falling due to hydraulic failure, or accidental activation of the operator's control. Lowering of the tool during transporting could result in loss of control of implement and / or tractor. The tractor drawbar must always be pinned for transport.

Transport Lock Valve

1. With the disc in the fully raised position, close the TRANSPORT LOCK VALVE.

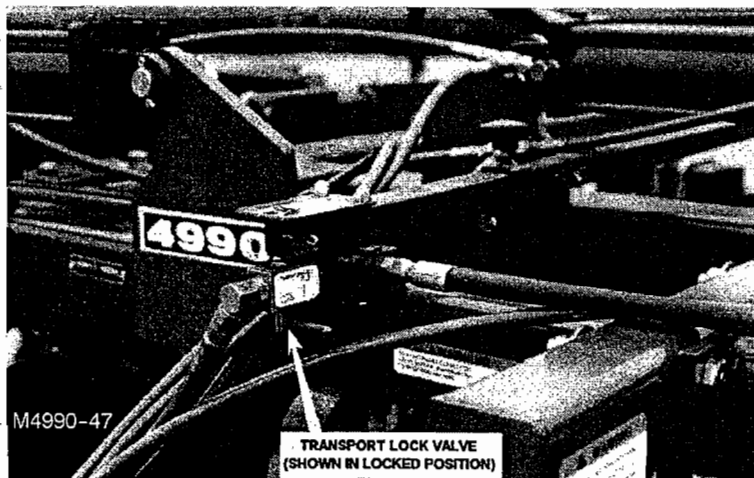
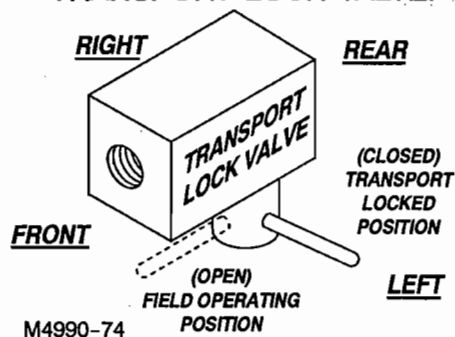

Raising The Wings

The disc should be in the raised position with the road lock valve in the closed position. If the system is full of oil, you are ready to raise the wings. The wings will be secured in the raised position with the locking pins when the wing clevis lock straps rest over the center frame lock strap. Holes in the wing lock straps are provided for lock pin storage.

⚠ Warning: Always stand clear of wings when they are in the raised position. A hydraulic failure or activation of hydraulic controls by someone could result in serious injury to anyone under the wings.



Lowering The Wings

To lower the wings, be sure the cylinders are retracted to the minimum stroke, then remove the wing lock pins and place in storage hole provided. Be sure you unlock both wings, then lower the wings with all persons standing at a safe distance away from the implement.

Transport Safety

NOTE: A safety chain, SMV emblem, and a light kit were furnished as standard equipment with your implement. Make sure they are in place, clean and in working order.

⚠ Warning: Always use a safety chain with a tensile strength equal to the gross weight of the unit, plus any attachments, when transporting. Do not tow this implement if its weight exceeds 1-1/2 times the weight of the towing unit.

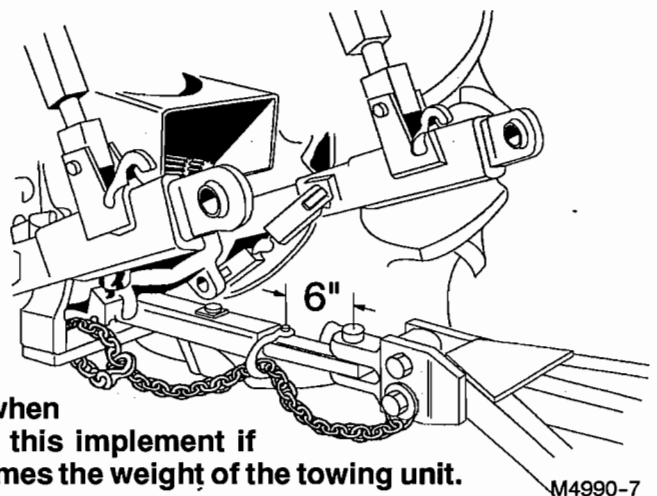

Attach the ASAE Slow Moving Vehicle (SMV) emblem. The emblem is to be mounted point up in a plane that is perpendicular to the direction of travel $\pm 10^\circ$. It shall be placed centrally at the rear of the vehicle, unobscured, and 2' to 6' (0.61 to 1.8m) above the ground, measured from the lower edge of the emblem. The SMV emblem should be wiped clean before entering the road or highways. A bracket has been provided.

⚠ Danger: Always check conditions of transport lock valve, tires, wheels, hubs, safety chain, hitch bolts, and clevis pin before transporting the implement.

Be aware of the transport height as well as the width of your model of disc. Care should be taken not to snag low hanging telephone lines or electrical service lines.

It is best to use a tractor to transport the disc to another location. If using another type of towing unit it should never be allowed to exceed 15 M.P.H., since implement tires are not constructed to be operated at higher speeds. The towing vehicle should always equal or exceed the gross weight of the disc and attachments.

Always check the tire pressure before transporting and look for damaged tires. Wobble the tires from side to side. If excessive play is noted, adjust the hub spindle nut before transporting to prevent damage to the hub or bearings.

⚠ Caution: It is very important to check wheel lug bolts after the first half mile of initial transport (delivery). If loose, tighten the 90 to 95 Ft. Lbs. torque. Continue to check frequently until they remain firmly seated.

Hitch Pin

Use the proper size hitch pin with a means for holding it in place so it cannot work itself out during transport. The hitch pin should be inspected for wear or cracks before using it to transport your field cultivator.

Comply with state and local laws pertaining to lighting and road widths. Turn on flashing lights whenever traveling on a highway except where it is prohibited by law. If the implement obscures the tractor warning lamp, a lamp must be added to the left of the implement. Transport during daylight hours only. Watch your clearance. Be aware of obstacles along the side of the roadway that might be caught by the disc harrow when passing by. Pull over to the side of the road to permit safe clearance for oncoming traffic. Keep the red and yellow reflectors clean and visible. Replace the reflectors if they become faded or damaged. Watch for pedestrians on the side of the road that need to be warned of your presence.

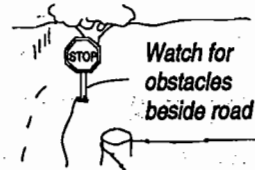

FIELD ADJUSTMENTS

THERE ARE (3) IMPORTANT RULES TO FOLLOW FOR PROPER FIELD ADJUSTMENT:

1. LEVEL THE IMPLEMENT FROM FRONT TO REAR.
2. LEVEL THE IMPLEMENT FROM SIDE TO SIDE.
3. SET THE STOP ON THE HYDRAULIC CYLINDER, AND CARRY THE WEIGHT OF THE IMPLEMENT ON THE WHEELS.

Front to Rear Leveling

1. Check the tongue cylinder lug location. There should be 1-3/4" between the paddle and the lock nut.
2. Check leveling spring length. It should be adjusted to 5-7/8 inches long as shown in the photograph to the right.
3. With the unit out of the ground and tongue cylinder fully extended, turn both leveling screws until frame is level from front to rear. NOTE: Turn clockwise to LOWER the front and counter-clockwise to RAISE the front.

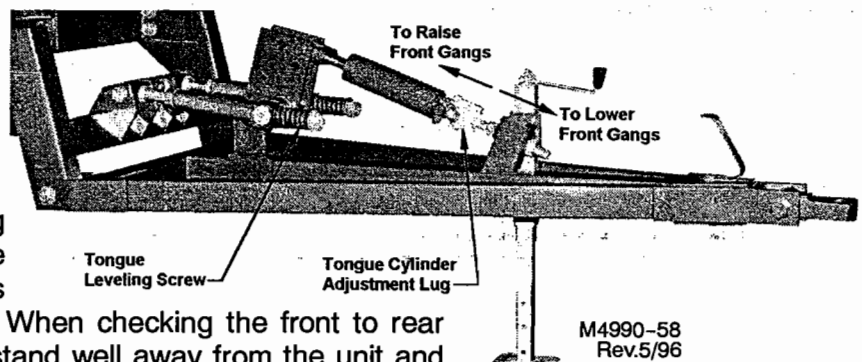
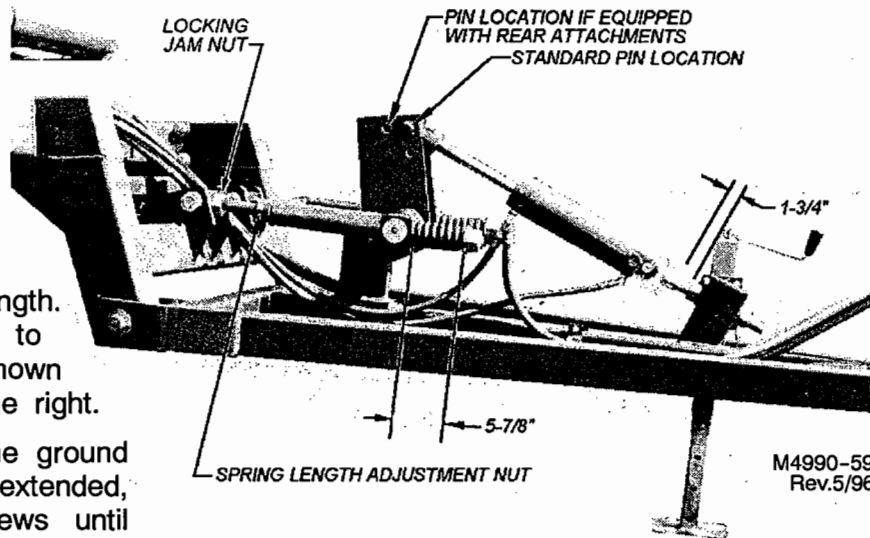

Some minor tongue leveling screw adjustment may be required when the disc is operated at plowing depth. When checking the front to rear leveling in the field, always stand well away from the unit and view the frames from frame height. The angle of the front frame members can give an illusion that the front gangs are running deeper than the back.

4. After the disc has been properly leveled at field depth, raise the unit to roading height and adjust the tongue cylinder lug until the disc is level.

Center Rocker Timing Link

IMPORTANT: **DO NOT** try to level the center frame with the TIMING LINK. The Timing Link adjustment is used to synchronize the two center rocker cylinders.

Note: The Timing Link comes preset at 22 inches long.

Check the timing by fully extending the rocker cylinders.

The Timing Link is set at the correct length if both cylinders fully extend at exactly the same time.

Shorten the Timing Link if the left cylinder fully extends before the right cylinder.

Lengthen the Timing Link if the right cylinder fully extends before the left cylinder.

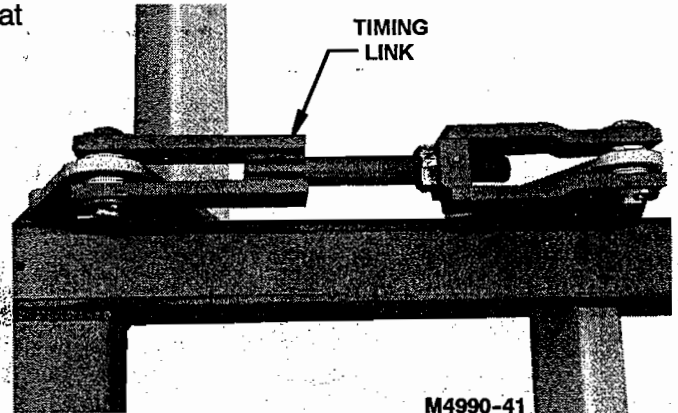

Leveling The Wings

The wings should operate level with the center section. View the frame with the disc stopped, but still in the ground. Determine if the wing needs to be higher or lower and then adjust the eyebolt at the base of the wing rocker cylinder as shown in the accompanying photograph.

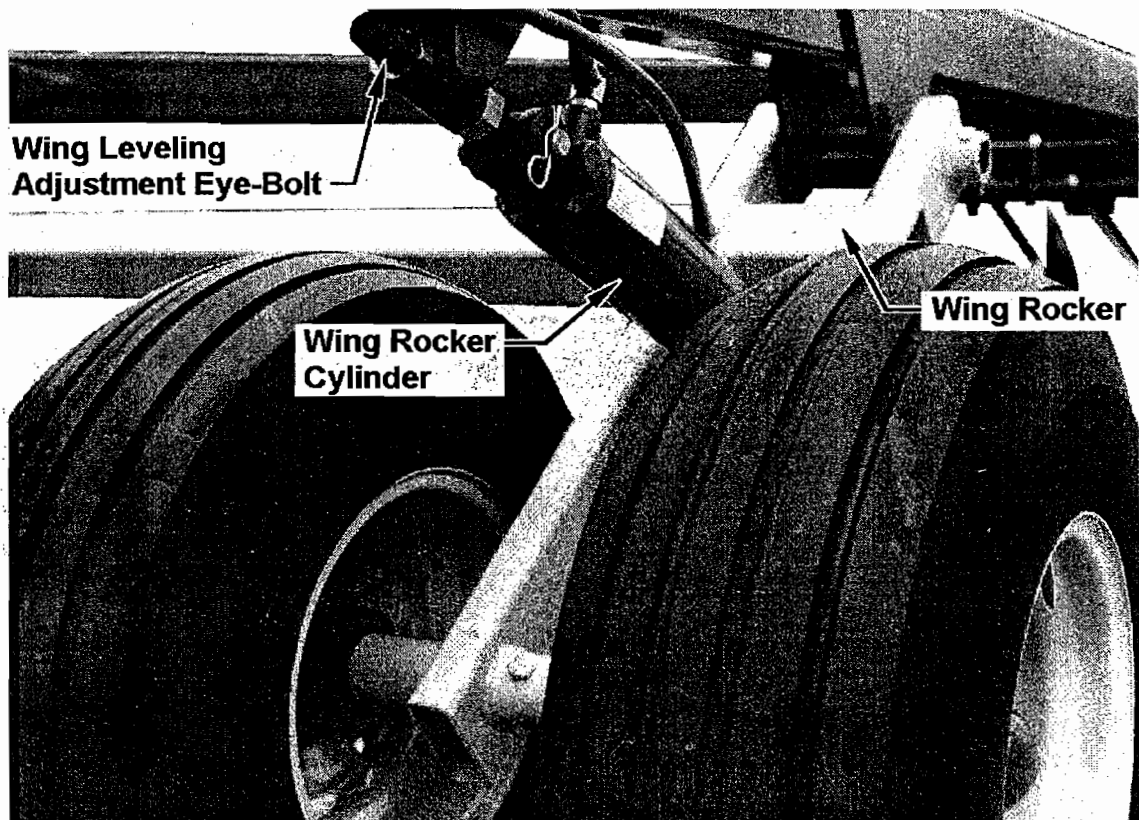

Hydraulic Depth Control Adjustment

The STOP VALVE controls the unit depth. When a depth change is required, loosen the knob and slide the striker closer to the valve to decrease depth or further away from the valve to increase depth. Moving the striker 3/8" will effect actual depth by 1". Tighten knob securely, but do not use a wrench or excessive force on the knob. If the unit depth varies during field operation, see the "Problem-Solving" section in this manual.

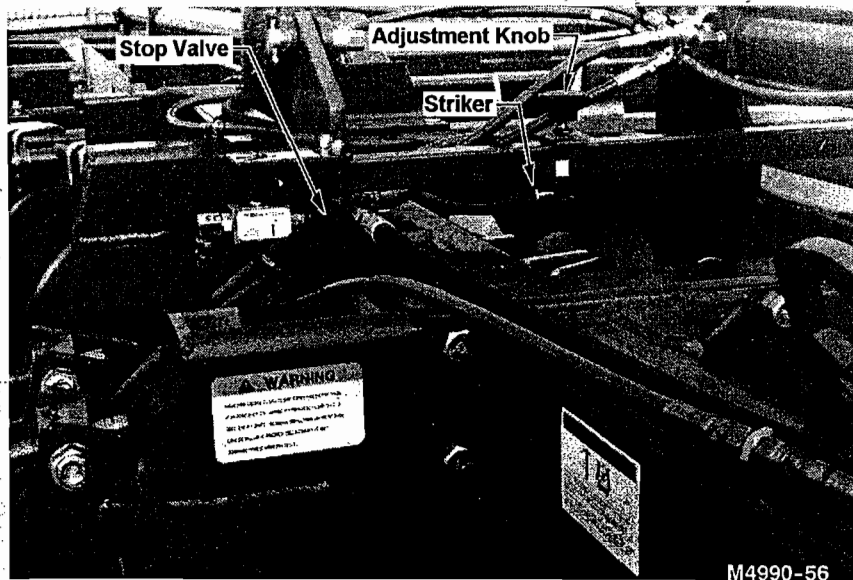

UNDERSTANDING YOUR HYDRAULIC DEPTH CONTROL SYSTEM

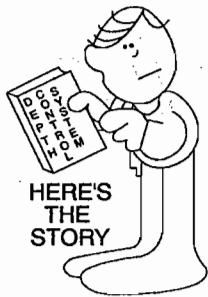

The 4995 Series Disc Harrow uses a master and slave system of depth control cylinders. The two center cylinders are the master cylinders and are connected together by using the center rocker shafts to keep both cylinders working in and out at the same time.

As oil is pumped into the base of the master cylinder, oil is forced out of the rod end and into the base end of its slave cylinder. In turn, this forces oil out of the slave cylinder which then returns to the tractor hydraulic reservoir.

Since there is a smaller volume of oil which passes from the rod end of the master cylinder to the base end of the each slave cylinder, the cylinders must be progressively smaller in diameter. In this system the master cylinders are 4-1/4" in diameter; the wing slave cylinders are 4" in diameter, and the tongue cylinder is 3-3/4" in diameter. All of the cylinders in this system have an 8" stroke length.

When the disc is raised completely out of the ground, these specially designed cylinders are synchronized for uniform lifting by holding the tractor remote hydraulic control lever in the raised position for a few seconds. This allows a small volume of oil to bypass from the base of the master cylinder to the base end of the slave cylinders, and back to the tractor. Consequently, all of the cylinders are fully extended simultaneously. To maintain a precise working depth, it may be necessary to synchronize the slave cylinders once or twice during each hour of use. This can be easily done when the unit is being raised to make a turn.

When working with this kind of arrangement, be sure all of the cylinders are mounted in proper sequence. Hoses must be attached in the proper order, and all air bled from the hoses and the cylinders. See page O13 under "HYDRAULICS" for synchronizing instructions.

REPAIR OF HYDRAULIC CYLINDERS SHOULD BY MADE BY AN AUTHORIZED KRAUSE DEALER ONLY.

A HYDRAULIC HOSE AND CYLINDER DRAWING CAN BE FOUND FOR EACH MODEL IN THIS SERIES ON PAGES P29 THROUGH P33 OF THE PARTS SECTION.

Rigid Scraper Adjustments

1. Scrapers can be adjusted by moving the entire assembly "A" from side to side at the bracket location.
2. Also, each scraper blade "B" can be adjusted individually along its mounting frame.

When scrapers are required, adjust blades so that the scraping edge of each scraper blade is flush against the disc blade, but not tight enough to prevent the gang from revolving freely. When scrapers are not required, adjust the scraper frame to move scraper blades away from disc blades. Under most conditions, scrapers should be positioned approximately 1"-2" in from the cutting edge and approximately 1/8" from the surface of the disc blades.

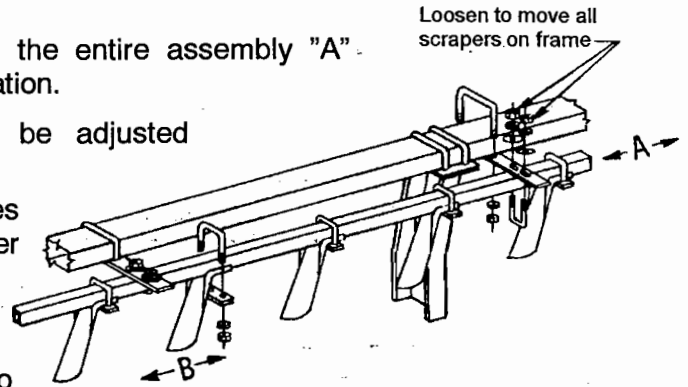

Each field requires some individual scraper adjustment. Moving scrapers one way or the other will help solve your individual scraper problems. The removal of the scraper blade at a bearing arm location may be necessary in some conditions. Frequent examination will prevent damage to scraper assemblies and spacer spools.

Some wet or heavy trash conditions may require use of chain trash guard option, Part Number 1582-146-0.

Spring Loaded Scraper Adjustments

Spring loaded scrapers can be adjusted towards or away from the disc blades by moving the entire assembly or moving individual scrapers, similar to the rigid scraper adjustments. Spring scrapers are in correct position when the scraper mounting plate is 1-1/2" from the edge of the disc blade as shown in the illustration below. In most conditions, the edge of the scraper blade should be approximately 3/4" in from the outside cutting edge of the disc blade. Use the following procedure to adjust the scraper blade force against the disc blade.

1. Loosen the adjusting nut until scraper blade starts to move away from the disc blade.
2. Retighten the adjusting nut until the scraping edge of the blade is just contacting the disc blade. (At this point there should not be any force against the disc blade.)
3. Tighten the adjusting nut one complete revolution for each 5 lbs. of scraper force desired against the disc. The initial setting should be approximately 15 lbs. or three complete revolutions.
4. In moderate conditions, a smaller scraper force may be desired and in tough conditions a larger force may be required. The scraper setting should fall between a 10 lb. minimum and a 30 lb. maximum setting.

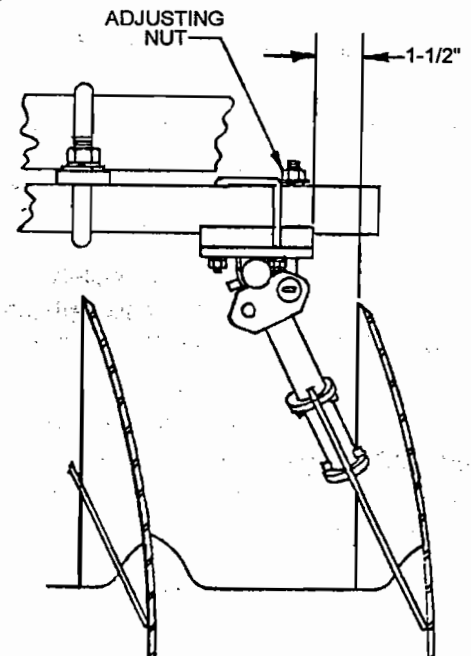

There is an adjustment wedge used to mount the spring scraper next to the extension trash bar loop on the rear outer disc blades. This scraper can be tilted towards the spool by tightening and loosening the nuts on the scraper U-Bolt. This scraper should be adjusted so that the scraper does not hang over the outside of the taper disc blades.

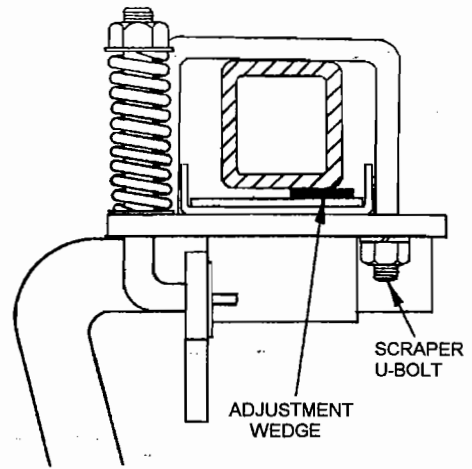

FIELD OPERATION

Working Depth

The depth of your disc harrow is controlled by the remote cylinder control lever(s) of the tractor. The wheels will act as gauge wheels to regulate working depth. Your disc harrow will not work uniformly, unless some weight of the unit is carried on the wheels. Speed will affect working depth. Do not expect maximum depth at high field speeds. Other factors affecting working depth are moisture conditions, amount of trash on surface, polish of disc blades, blade spacing and blade sharpness.

MODELS 4995-28NR through 4995-36WR -- Remember to reduce speeds when working in extremely rocky conditions. Field speeds should not exceed 5 m.p.h. You will get better penetration and less blade breakage at lower speeds.

Flexibility

ALWAYS WORK WITH WINGS DOWN: Major damage may occur to disc blades and bearing arms if used with the wings up. For maximum flexibility, make sure the wing fold hydraulic cylinders are fully extended after the wing is down.

When working terraced ground, place the wing up on the terrace, not down over the terrace, as the wings are limited in their downward movement, but not in their upward movement.

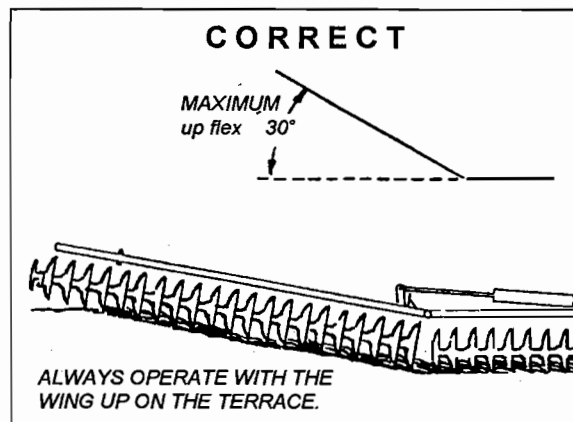
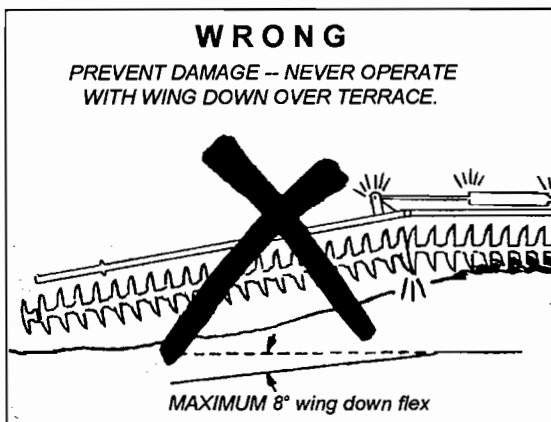

Turning In The Field

Short turns at working depth may result in driving the front blade deeper in the ground, causing damage to disc blades or bearings. If short turns must be executed, raise the disc out of the ground and complete the turn before engaging the tool for further tilling.

IMPORTANT: 4-WHEEL DRIVE TRACTORS CAUSE SEVERE SIDE STRAIN ON TONGUE AND CLEVIS UNLESS THE DRAWBAR IS FREE TO SWING. ALWAYS ALLOW DRAWBAR TO SWING DURING FIELD OPERATION. DRAWBAR MUST BE PINNED FOR TRANSPORTING.

General Information

Different soil types require different blade sizes, thickness, and spacing.

As a general rule, heavy wet soils require wider spacing. For a finer seed bed preparation, narrow spacing should be used.

1/4" thick blades should be used in extremely hard or rocky conditions. Blade diameter is an individual preference.



Caution: Never add weight to the implement to gain added penetration. Overloading of tires and axles may cause damage to the disc harrow.

STORAGE SUGGESTIONS

Wings should **not** be stored in the raised position. Make sure transport lock valve is in the closed position. The center cylinder locks should also be placed onto the extended cylinder rods.

For long term storage, coat disc blades and hydraulic cylinder rods with rust preventative. For added safety lower the disc to the ground. Cylinder rods may also be unpinned and retracted to protect the polished rod surfaces. Inspect the disc for worn or damaged parts and replace as needed to avoid delays the next season.

SERVICING

General Maintenance

All nuts should be checked and tightened during and after the first 1/2 day of operation, and periodically thereafter. Keep tires inflated to the recommended pressure, and check the wheel bolts until they are firmly seated. Hydraulic hoses should be checked for wear and pinched areas and replaced if necessary. Check disc gang tie rods frequently and keep tight at all times. Torque tie rods to 1,200 Ft. Lbs.

The Krause Disc is a ruggedly designed implement which will perform efficiently if properly adjusted and maintained. Keep blades sharp.

FOR YOUR SAFETY: when lubricating or making adjustments on your disc harrow, watch for obstructions and protrusions. Lower wings and implement to the ground and enter framework by stepping over. Do not walk on tires.

Lubrication



The initial lubrication of all grease fittings will assure long life and satisfactory performance from the disc. Minimum lubrication is required. Use a multi-purpose type grease at all grease zerk locations after each 40 hours of operation. Points of lubrication are: Rocker shaft pivots, hinge tubes, disc gang bearings, and tongue adjustment screws. Wheel hubs should be greased every 24 hours.

Walking Beams

Grease the walking beam bearing every 24 hours of use. When greasing the bearings, lower the unit onto the disc blades and raise the walking beams off the ground. Check each walking beam for any slack in the pivot bearings. When the slack is found, tighten the axle nut until slack is eliminated and tighten 25 to 30 Ft. Lbs. of preload on the bearings. **DO NOT BACK THE AXLE NUT OFF.** Check, clean, and repack the walking beam bearings each year in a procedure that is similar to that of the wheel bearings.

Wheel Bearings

Grease wheel bearings every 24 hours of use. Check for excessive end play each time bearings are greased. Once a year, clean and repack wheel bearings with EP#2 Grease. Replace seals each time bearings are removed. Replace any worn or damaged parts. After repacking, replace hub with seal and rear bearing already assembled. Use light oil on seal surface and use extreme care when pushing seal over the spindle. Install outer bearing, flat washer, and slotted nut. Tighten nut while turning hub until there is resistance to rotation. Then back off nut from 1 to 2 slots until hub turns freely without end play. Secure nut with clinched cotter pin.

Disc Gangs

Before attempting to work on the disc gang components, remove the cylinder locks from their storage position and install them on the center extended cylinder rods as shown below right. Both locks must be installed.

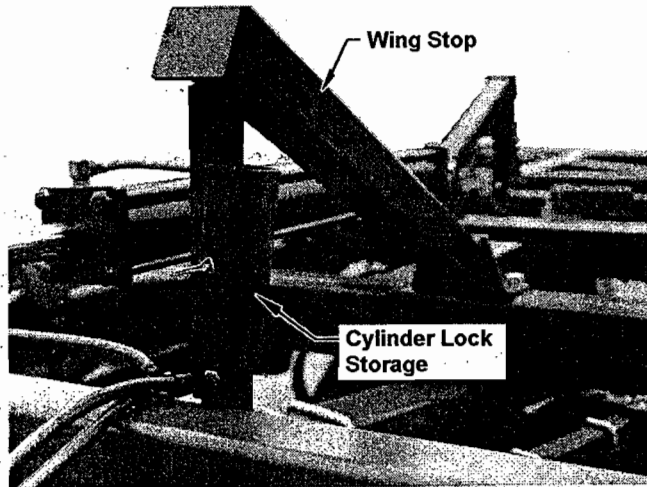

M4990-46

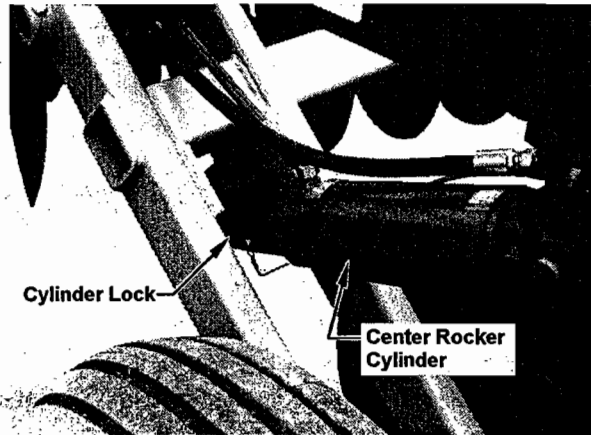

M4990-57

Block the center tires and support the outer wing frame beams with stands.

⚠ Danger: Due to their sharpness and weight, serious injury can be inflicted by disc blades and disc gangs if not handled safely. Watch for unsafe conditions. Keep your co-workers safety in mind. Should personal injury occur, have medical treatment administered immediately.

Use the same procedure as described when setting up a new unit. Make sure the top of the bearing arms are parallel with the bottom of the frame before tightening the tri-bolts.

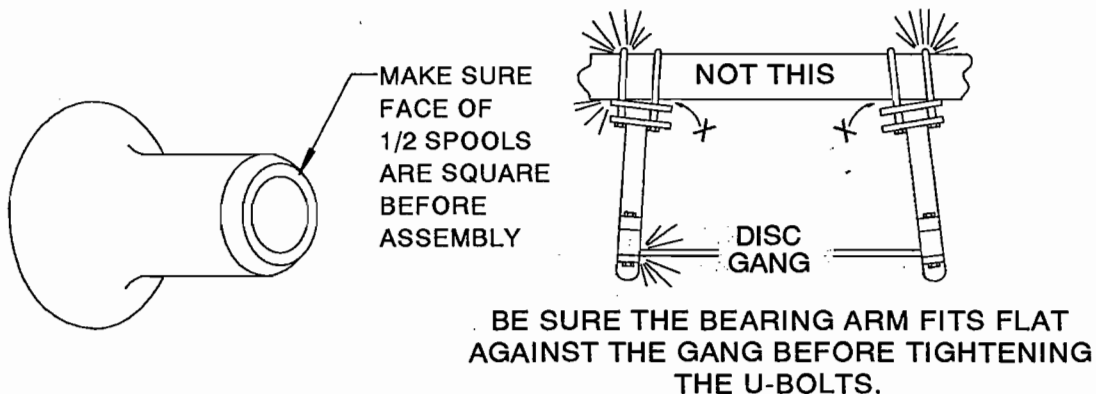

Repair Parts

Refer to the Assembly Section of this book when repairing or replacing parts, and follow the same procedure as used when assembling a new unit. Reverse this procedure for disassembly. The Parts Section of this manual will show a breakdown of assemblies, location of parts, and part numbers.

KRAUSE PARTS WERE DEVELOPED AND TESTED FOR THESE HARROWS, therefore, it is recommended that KRAUSE replacement parts be used..

⚠ Caution: If replacing hydraulic hose, use only hose that meets or exceeds 3,000 PSI working pressure.

IMPORTANT: REPAIR OF HYDRAULIC CYLINDERS SHOULD BE MADE BY AN AUTHORIZED KRAUSE DEALER.

⚠ Caution: Explosive separation of a tire and rim parts can cause serious injury or death.

Always maintain the correct tire pressure. Do not inflate the tires above the recommended pressure. Inspect tires and wheels daily. Do not operate with low pressure, cuts, bubbles, damaged rims or missing lugbolts and nuts.

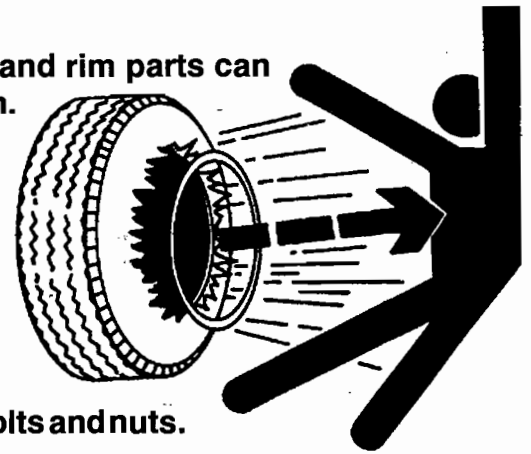

Hydraulics

If the implement wing lift system has never been used, stored over a period of time or disassembled for any reason, unpin the rod ends of the cylinders and support the cylinders so that the rod ends will clear frame members or lugs when fully extended. Back the tractor to the front of the disc and connect the hydraulic hoses to the tractor. Check the tractor hydraulic reservoir and make sure it is full of the tractor manufacturer's recommended oil. If you are sure the implement hydraulic hose connections are tight, begin filling the system by extending and retracting the cylinders. Hold the control lever open and pause at the end of each stroke of the cycles to bleed the air from the system. Continue the cycles until the cylinders respond with immediate solid actuation. When you are sure the systems are free of air, pin the rod ends of the cylinders to the implement cylinder lugs.

⚠ Warning: Escaping fluid under pressure can penetrate the skin causing serious injury. Avoid the hazard by relieving pressure before disconnecting hydraulic lines. Tighten all connections before applying pressure.

Search for leaks with a piece of cardboard. Protect hands and body from high pressure fluids.



If an accident occurs, see a doctor immediately. Any fluid injected into the skin must be surgically removed within a few hours or gangrene may result.

Avoid Heating Near Pressurized Fluid Lines

Flammable spray can be generated by heating near pressurized fluid lines, resulting in severe burns to yourself and bystanders. Do not heat by welding, soldering, or using a torch near pressurized fluid lines or other flammable materials. Pressurized lines can be accidentally cut when heat goes beyond the immediate flame area.

SUGGESTED REMEDIES FOR HYDRAULIC PROBLEMS

PROBLEM	POSSIBLE CAUSE	SUGGESTED REMEDY
Disc raises and lower slowly	Restrictor fitting in rocker shaft cylinder	Check for restrictor ell and replace with standard fitting. Note: All wing lift cylinder ports should have restrictor ells.
Rocker cylinders are settling after rephasing	Rephasing groove in cylinder	It is normal for a rephasing cylinder to settle approximately 3/8" until the piston is past the rephasing groove.
All rocker cylinders settling at mid-stroke	Tractor valve leaking	Repair tractor valve
Cylinder has spongy or erratic movement	Air in the hydraulic system	Purge the system of air as described on page O13.
Cylinder retracting or extending out of sequence	Leaking seal .. Air in hydraulic system .. Scarred cylinder wall	Check for external leaks Locate internal piston leak as described on the following pages. Purge air from system. See page O13 Locate internal leak as described on the following pages.

IMPORTANT: REPAIR OF HYDRAULIC CYLINDERS SHOULD BE MADE BY AN AUTHORIZED KRAUSE DEALER.

TEST PROCEDURE TO LOCATE INTERNAL LEAKING CYLINDER IN A REPHASING SYSTEM

1. Raise the unit until the disc blades are 4" to 5" above the ground, but do not fully extend the cylinder.
2. Measure the length of the four rocker cylinders and tongue cylinder; record those lengths.
3. Allow the unit to sit for a period of time until there is a measurable change in one of the cylinder lengths. This may require an hour or two. (Preferably overnight)
4. Measure the length of each cylinder again and note whether or not the cylinder extended or retracted.
5. Match your results to one of the six case studies shown on the following pages to locate the leaking cylinder.

CASE 1: Symptom: Left wing lowering as the disc is pulled in field

Probable Causes: (A) Left wing cylinder piston seal leak-

Test Results: (See page O14) Left cylinder retracts, all other cylinders do not change.

Leaking Cylinder: Left Wing Rocker Cylinder

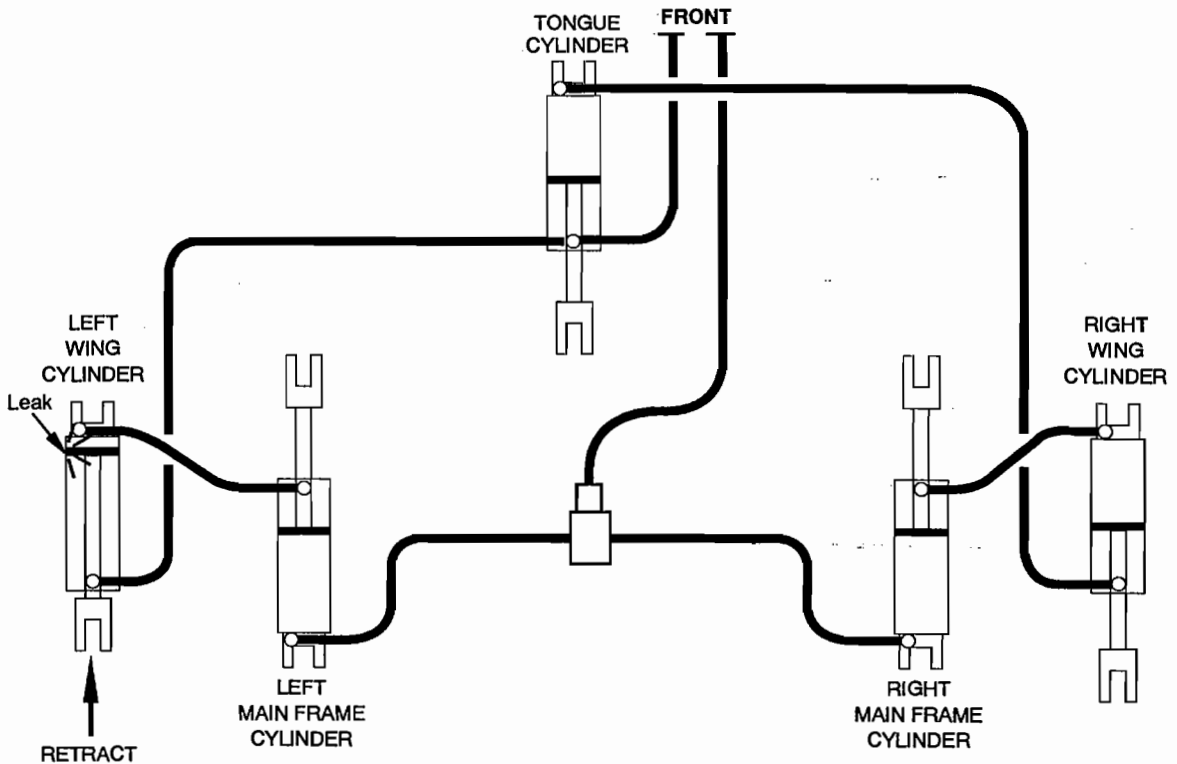

M4990-77

CASE 2: Symptom: Left wing raising as the disc is pulled in the field

Probable Causes: Left main frame cylinder piston seal leak

Test Result: (See page O14) Left wing cylinder extends, all other cylinders retract.

Leaking Cylinder: Left Main Frame Rocker Cylinder

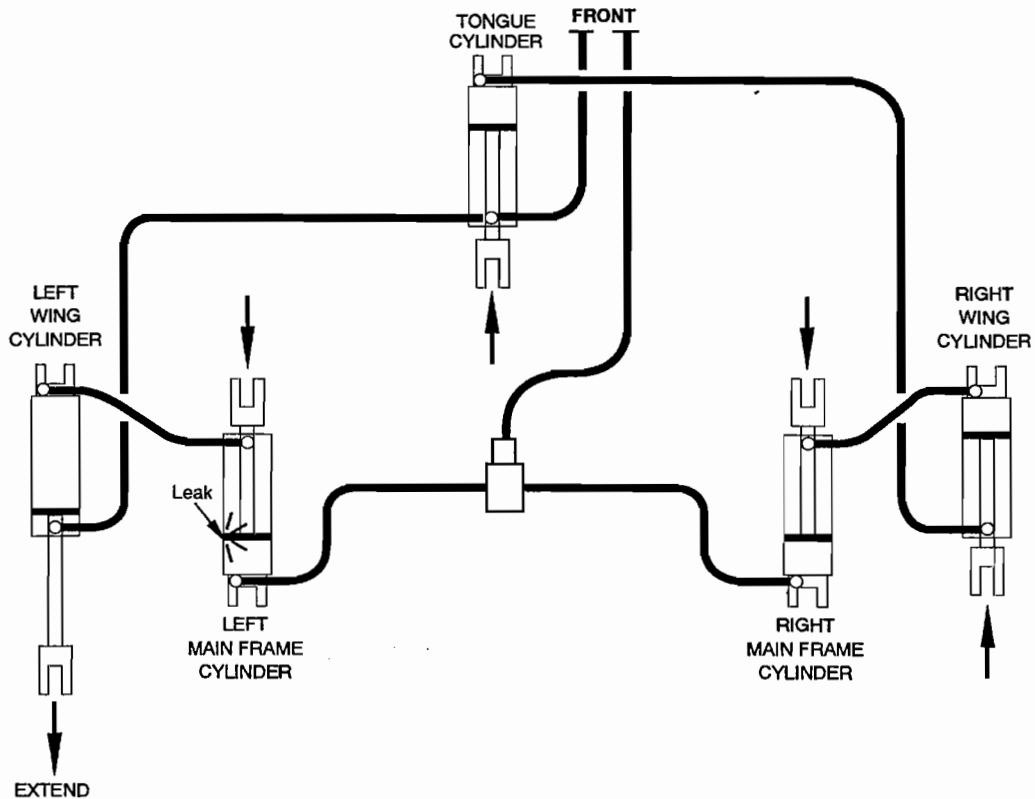

M4990-78

CASE 3: Symptom: Right wing lowering as the disc is pulled in field.

Probable Cause: Right wing cylinder piston seal leak.

Test Result: (See page O14) Right wing cylinder retracts, tongue cylinder extends slightly, all other cylinders do not change.

Leaking Cylinder: Right Wing Rocker Cylinder

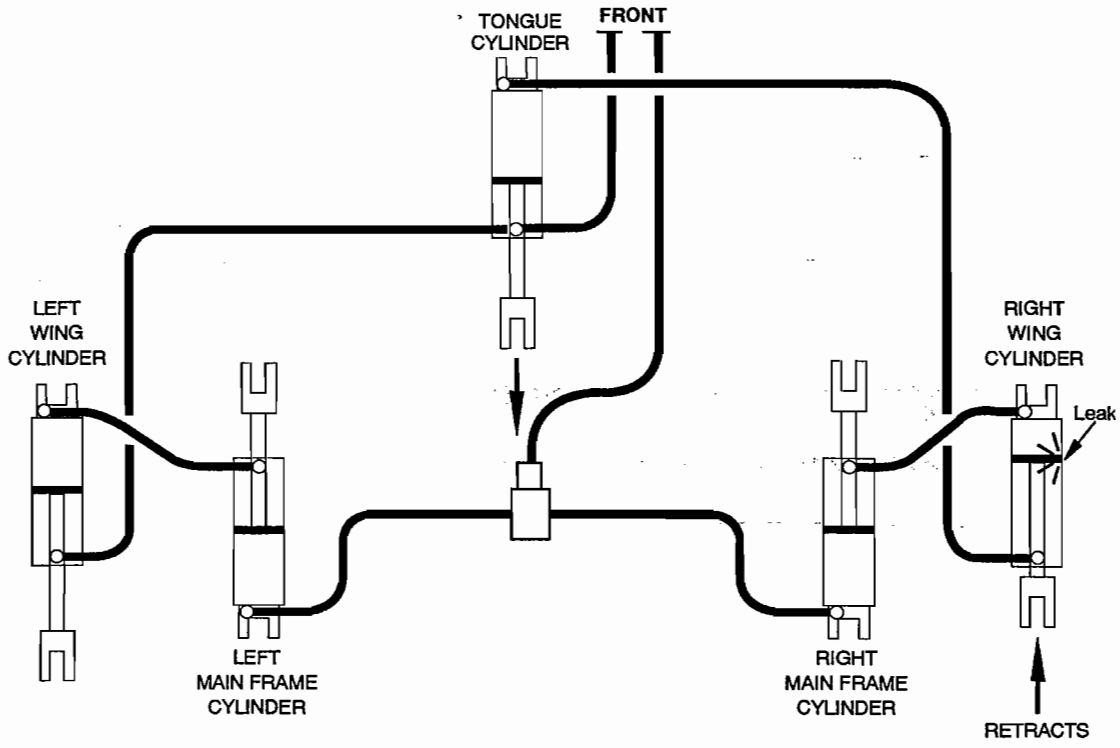

M4990-7

CASE 4: Symptom: Right wing raising as the disc is pulled in field.

Probable Cause: Right main frame cylinder piston seal leak.

Test Result: (See page O14) Right wing and tongue cylinder extend, all other cylinders retract.

Leaking cylinder: Right Main Frame Rocker Cylinder

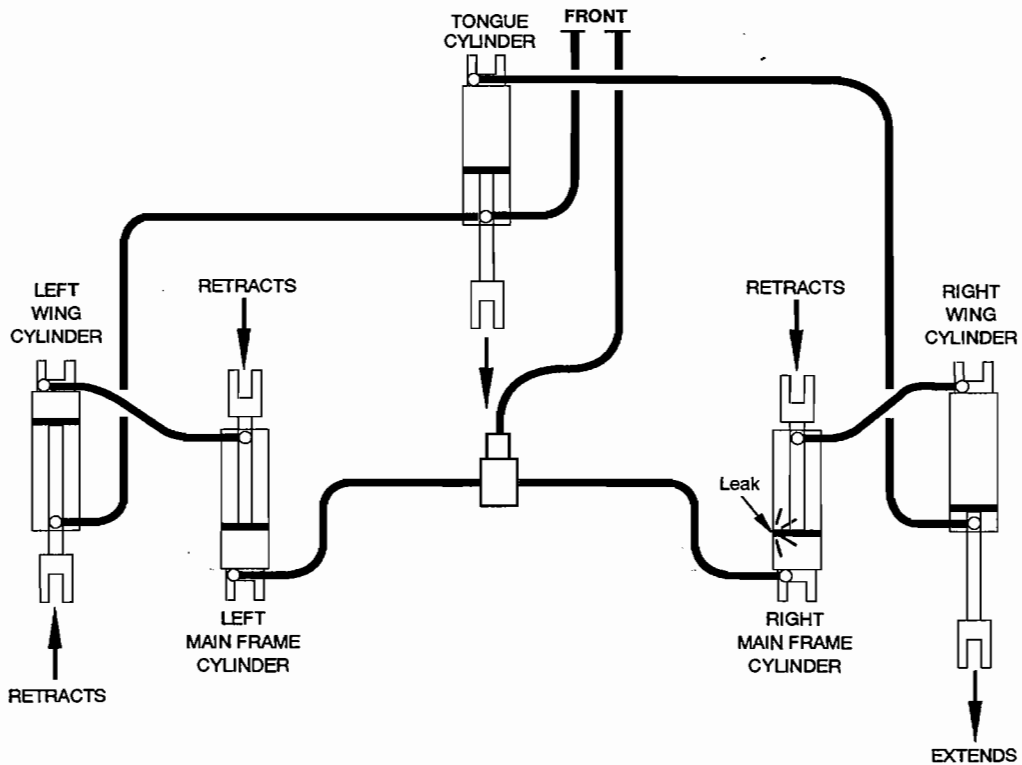

M4990-80

CASE 5: Symptom: Tongue leveling cylinder changing as disc is pulled in field

Probable Cause: Tongue Cylinder piston seal leak

Test Results: (See page O14) Tongue cylinder retracts, all other cylinders do not change.

Leaking Cylinder: Tongue Cylinder.

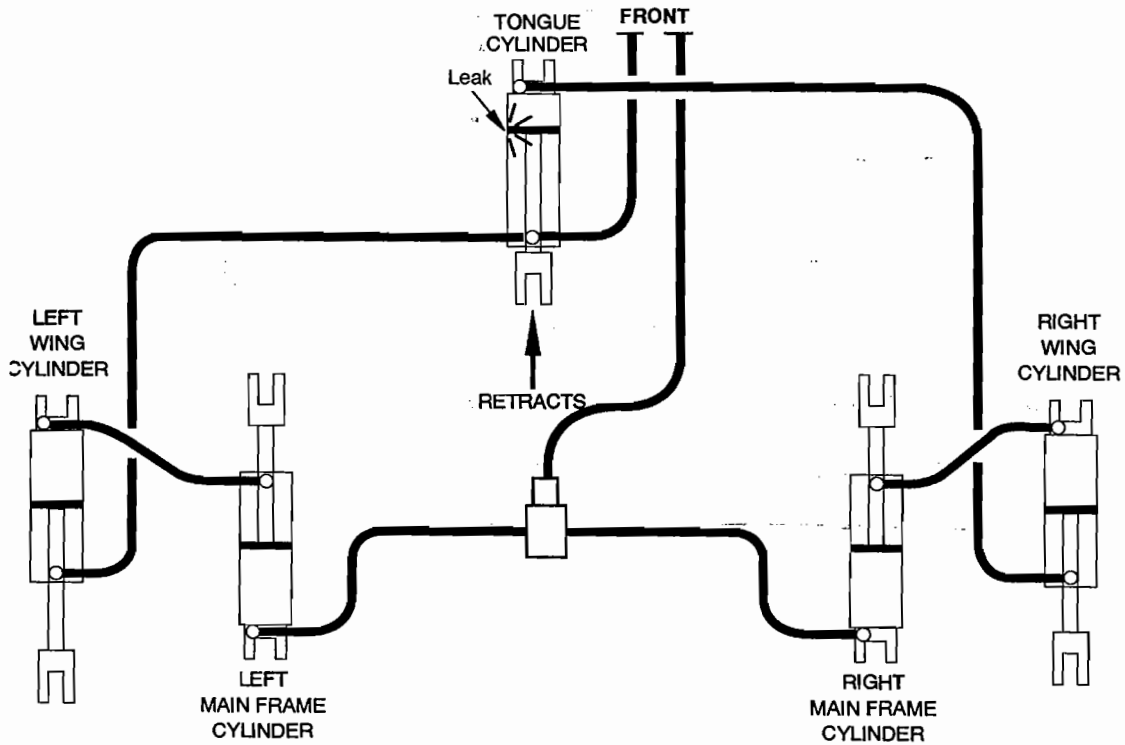

M4990-81

CASE 6: Symptom: Entire disc will not maintain set depth

Probable Cause: Tractor Valve leaking

Test Results: (See page O14) All cylinders are retracting or extending at the same time.

Leaking Cylinder: Tractor Valve

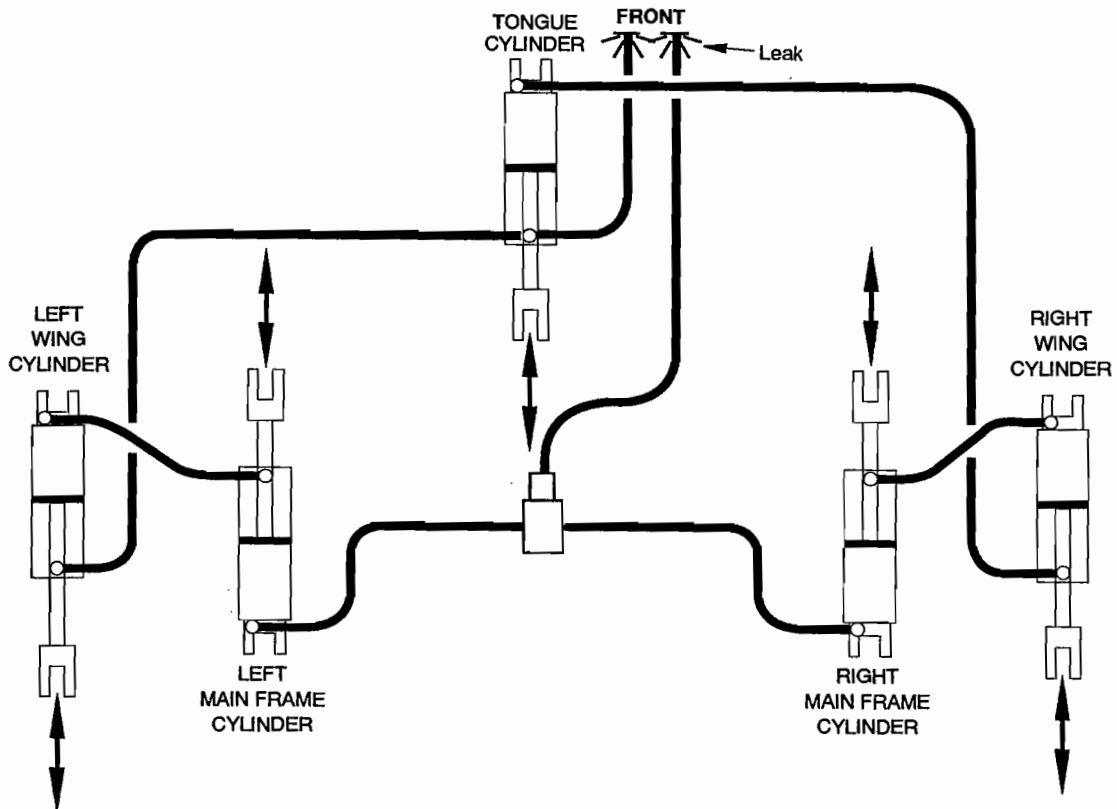

M4990-82

SUGGESTED REMEDIES FOR FIELD PROBLEMS

PROBLEM	POSSIBLE CAUSE	SUGGESTED REMEDY
Leaving Center Ridge	Excessive Speed	Reduce Speed
	Rear gangs cutting too deep	Shorten length of tongue adjustment screws
		Reduce tension on leveling screws
	Rear discs are set too close together	Readjust distance between inside disc blades. Reduce size of inside rear disc blades
Leaving center furrow	Discing too slowly	Increase speed, do not exceed 6 m.p.h. rigid models, 5 m.p.h. rock flex models
	Rear gang not cutting deep enough	Lengthen tongue adjustment screws
	Rear blades are too far apart	Readjust distance between disc blades
Leaving untilled center strip	Discing too shallow	Increase depth
	Front center gangs too far apart	Move front center gangs in
	Front center gangs overlapped too much	Move front center gangs out
Leaving furrow on outside	Rear running too deep	Readjust tongue leveling screws
	Extension disc blade incorrect size	Decrease size of extension disc blade
Leaving ridge on outside	Front running too deep	Adjust tongue leveling screw
	Not enough overlap	Move tractor toward plowed ground
	Wing section running too deep	Increase size of extension disc blades
	Excessive speed	Reduce speed
Center section not level from side to side	Incorrect air pressure in tires	Inflate 10.00 x 15, 8-ply tires to 40 PSI
	Timing link not set correctly	Readjust timing link so that both center cylinders fully extend at the same time (See Timing Link page O7)
Wings not level from side to side	Wing too high	To lower wing, short wing adjust. screw
	Wing too low	To raise wing, lengthen wing adjust. screw
	Wing lift cylinder not fully extended	Extend cylinder to maximum length and hold open briefly
	Slave cylinders out of phase	Raise unit out of ground and hold control lever open until all cylinders are completely extended
Disc not level from front to rear during operation	Tongue adjustment screw setting	Lengthen screw to RAISE front, Shorten screw to LOWER front

PROBLEM	POSSIBLE CAUSE	SUGGESTED REMEDY
Disc not level during transport	Tongue cylinder lug adjustment	Adjust tongue cylinder lug .. Adjust tension on leveling screw springs
Gangs plugging	Extremely wet field conditions	Decrease depth of work or allow field to dry if possible
	.. Worn or improper adjustment of scraper blades	Readjust scrapers and replace worn parts
Gang does not revolve	Obstruction in disc gang	Check for rocks, mud, roots, etc.
	.. Scrapers	Check for scrapers adjusted too tight to disc blades
	.. Seized bearing	Replace
	.. Plugging at bearing arm	Try removing scraper at this location
Wing will not flex down far enough	Wing lift cylinder	Make sure cylinders are fully extended
Disc will not penetrate or penetrates too much	Depth valve striker setting on wheel control cylinders	Readjust depth control striker (see page O8)
Wheels have excessive wobble	Loose wheel bolts	Immediately stop. Torque wheel bolts 90 to 95 Ft. Lbs.
	.. Loose spindle nut	Tighten nut until tight, then back off one to two notches
Discs have excessive wobble	Tie rod nut loose	Re-torque nut on tie rod to 1200 Ft. Lbs.
Disc will not lower or wings will not lower	Transport locks engaged	Open transport lock valve .. Disengage center cylinder locks .. Disengage wing lock pins
Wings will not raise to transport position	Plugged restrictor	Remove restrictors from ends of cylinder check orifice for foreign material
	.. Insufficient hydraulic pressure	Check tractor hydraulic system
Inadequate transport clearance	Wheel control cylinders not extended ..	Extend cylinders
	.. Tire pressure low	Inflate 10.00 x 15, 8-ply tires to 40 PSI
	.. Disc not level from front to rear	Adjust tongue cylinder adjustment lug

This page intentionally left blank.

PARTS SECTION

THE FOLLOWING ILLUSTRATED PARTS SECTION HAS BEEN COMPILED TO REFLECT PART NUMBERS REQUIRED TO ORDER PARTS, AND TO SUPPORT THE ASSEMBLY SECTION FOR DIMENSIONS AND DESCRIPTIONS OF ALL PARTS, BOLTS, PINS, ETC. THE OPERATOR CAN ALSO IDENTIFY PART NAMES TO CLARIFY PROPER OPERATIONAL STEPS.

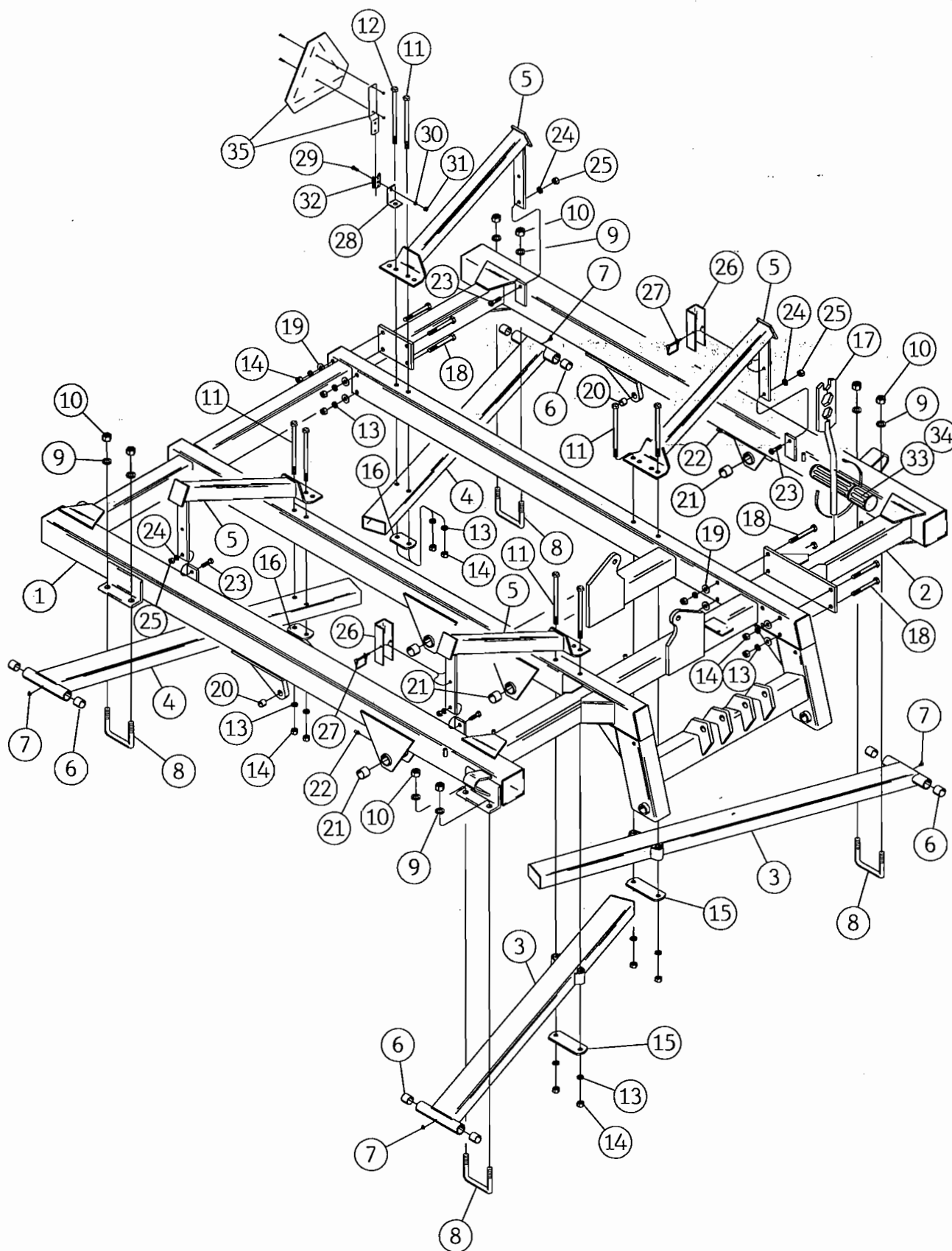

M4990-102
Rev. 12/00

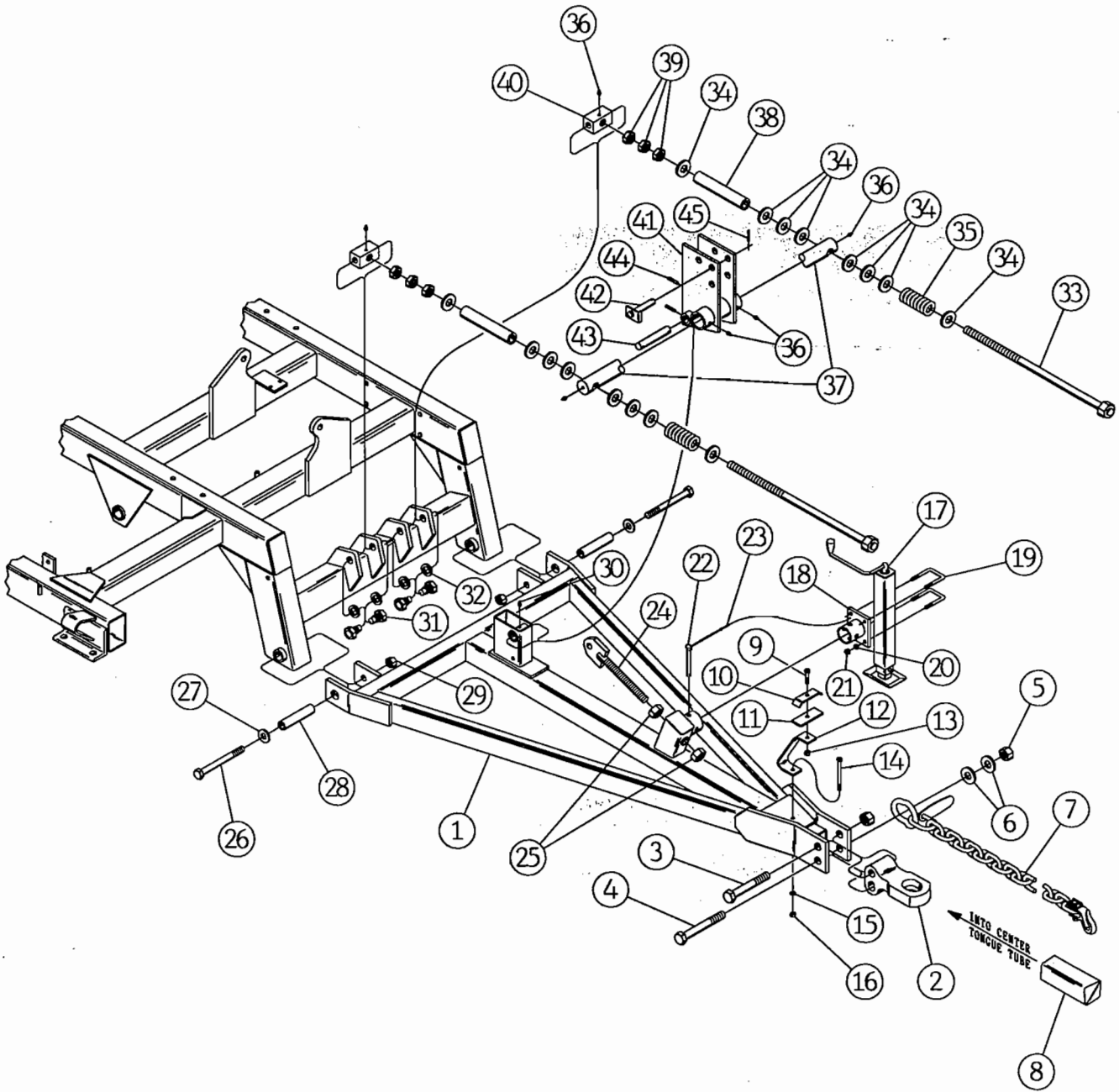

TONGUE ASSEMBLY

FOR MODELS - ALL

7/97

Item	Part Number	Part Description	Qty.
1	4987-30-0	Tongue Weldment	1
2	5215-0-4007A	Hitch Clevis Casting (2-1/8" x 2-1/2" Slot) Standard	1
3	62-275	1-1/4NC x 7-1/2" Bolt	1
4	62-279	1-1/4NC x 8-1/2" Bolt	1
5	63-126	1-1/4NC Lock Nut	2
6	64-126	1-1/4" STD. Flat Washer	2
7	72-352	20,000# Safety Chain Assembly	1
8	4956-0-15	Tongue Weight Casting (Accessory Item)	7
9	62-142	1/2NC x 2" Cap Screw	1
10	2426-170-5	Hose Clamp	1
11	2145-170-5	Plate	1
12	4901-0-12	Hose Stand	1
13	63-107	1/2NC Lock Nut	1
14	62-395	1/2NC x 6" GD.5 Cap Screw	1
15	64-107	1/2" STD. Lock Washer	1
16	63-106	1/2NC Hex Nut	1
	4956-56-0	Jack Assembly	1
17	73-111	Jack Assembly	1
18	4956-55-0	Jack Mounting Bracket Weldment	1
19	61-172	1/2" DIA. U-Bolt	2
20	64-107	1/2" STD. Lock Washer	4
21	63-106	1/2NC Hex Nut	4
22	60-106	Fas-Pin with Chain	1
23	60-702	3/16" DIA. x 1-1/2" Cotter Pin	1
24	1844-51-0	Adjustment Cylinder Lug Weldment	1
25	63-123	1-1/4NC Hex Nut	2
26	62-260	1NC x 9" Bolt	2
27	64-119	1" STD. Flat Washer	2
28	4956-0-2	Bushing	2
29	63-119	1NC Lock Nut	2
30	65-101	1/8" STD. Zerk	1
31	4901-46-0	Pivot Bolt	4
32	64-125	1-1/4" STD. Lock Washer	4
	4987-35-0	Leveling Spring Assembly	1
33	99-115	Adjustment Screw Weldment	2
34	64-126	1-1/4" STD. Flat Washer	16
35	76-122	Spring	2
36	65-101	1/8" STD. Zerk	6
37	4956-35-1	Spring Pin	1
38	4987-35-1	Sleeve	2
39	63-124	1-1/4NC Hex Jam Nut	6
40	4956-35-3	Trunnion	2
41	4987-36-0	Spring Rocker Weldment	1
42	4956-34-0	Lock Pin Weldment	1
43	4956-0-16	Pivot Pin	1
44	60-615	3/8" DIA. x 2" Roll Pin	2
45	60-606	1/4" DIA. x 2" Roll Pin	1
46	3950-0-10	Single Clevis (1-5/8" x 2-1/8" Slot) Optional	1
47	3950-0-11	Double Clevis (1-3/8" MAX. Pin DIA.) Optional	1

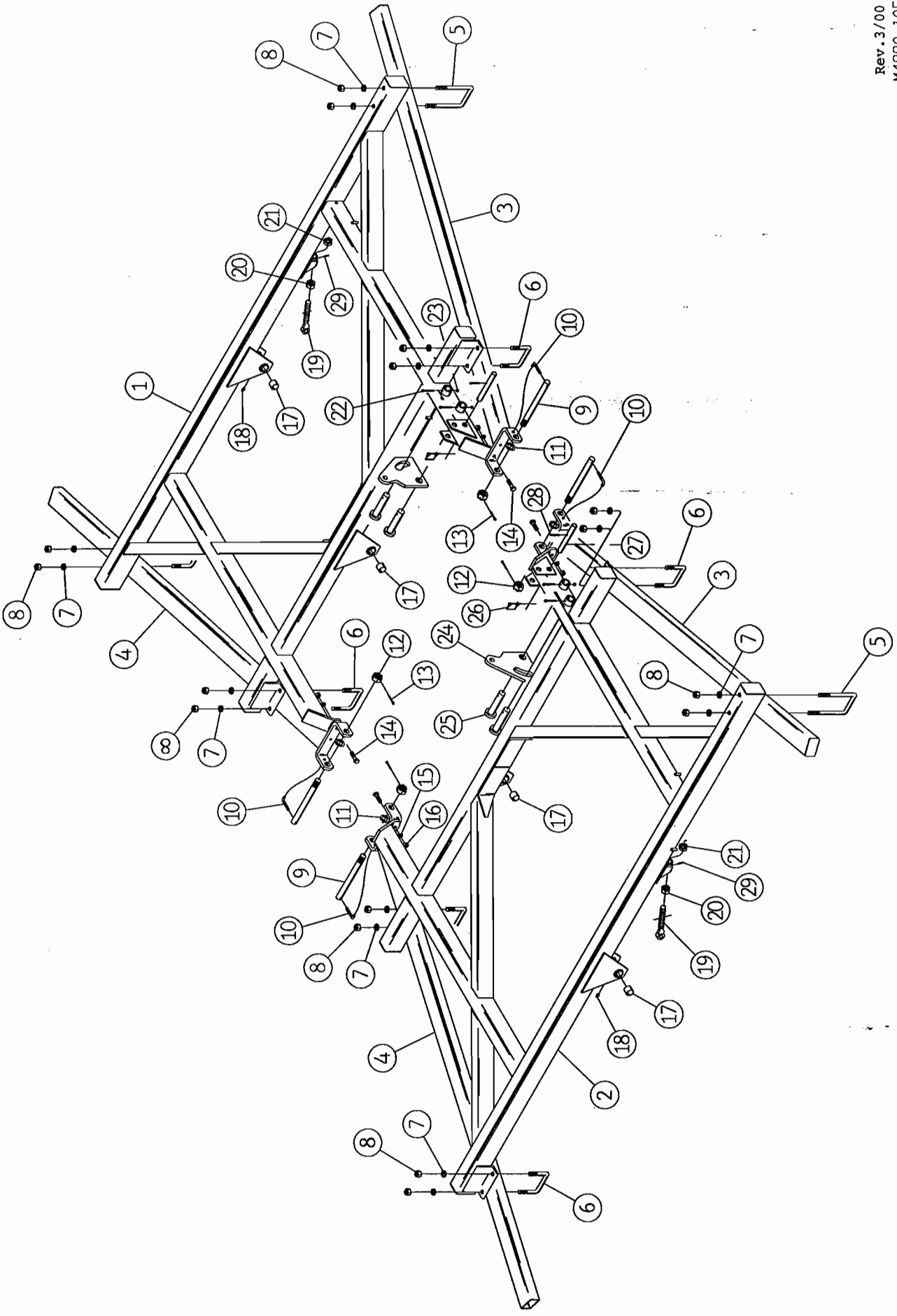

WING FRAMES & GANG BEAMS

FOR MODELS - ALL

12/00

Item	Part Number	Part Description	Qty.
1	★ 4988-18-0A	Left Wing Frame Weldment	1
	● 4991-18-0A	Left Wing Frame Weldment	1
	■▲ 4994-18-0A	Left Wing Frame Weldment (SHOWN)	1
2	★ 4988-20-0A	Right Wing Frame Weldment	1
	● 4991-20-0A	Right Wing Frame Weldment	1
	■▲ 4994-20-0A	Right Wing Frame Weldment (SHOWN)	1
3	★ 4988-23-0A	Front Wing Beam Weldment	2
	● 4991-23-0A	Front Wing Beam Weldment	2
	■ 4994-23-0A	Front Wing Beam Weldment (SHOWN)	2
	▲ 4996-23-0A	Front Wing Beam Weldment	2
4	★ 4988-22-0	Rear Wing Beam Weldment	2
	● 4991-22-0	Rear Wing Beam Weldment	2
	■ 4994-22-0	Rear Wing Beam Weldment (SHOWN)	2
	▲ 4996-22-0	Rear Wing Beam Weldment	2
5	61-170	1" DIA. U-Bolt (Long Leg)	2
6	61-239	1" DIA. U-Bolt (Short Leg)	6
7	64-118	1" STD. Lock Washer	8
8	63-117	1NC Hex Nut	8
9	4901-0-1	Hinge Pin	4
10	1901-0-2	Hinge Lock Pin	4
11	64-145	2-1/2" O.D. x 1-5/8" I.D. Wear Washer	4
12	63-128	1-1/2NC Slotted Hex Nut	4
13	60-711	1/4" DIA. x 3" Cotter Pin	4
14	62-195	3/4NC x 2-1/2" GD5 Cap Screw	4
15	64-112	3/4" STD. Lock Washer	4
16	63-112	3/4NC Hex Nut	4
17	53-110	Wear Sleeve	6
18	65-101	1/8" STD. Zerk	2
19	61-249	1-1/4" DIA. Eye Bolt	2
20	63-123	1-1/4NC Hex Nut	2
21	63-124	1-1/4NC Hex Jam Nut	2
22	62-120	3/8NC x 3" GD5 Cap Screw	4
23	63-103	3/8NC Lock Nut	4
24	4956-0-9	Wing Lift Lug	2
25	4956-6-0	Pin Weldment	4
26	60-103	P.T.O. Lock Pin	2
	4956-45-0	Lock Pin Assembly	2
27	4956-45-1	Lock Pin	1
28	60-617	3/8" DIA. x 2-1/2" Roll Pin	1
29	60-614	3/8" DIA. x 1-3/4" Roll Pin	2
★ For Model 4995-28 ONLY (4995-28N through 4995-28WR)			
● For Model 4995-31 ONLY (4995-31N through 4995-31WR)			
■ For Model 4995-34 ONLY (4995-34N through 4995-34WR)			
▲ For Model 4995-36 ONLY (4995-36W & 4995-36WR)			

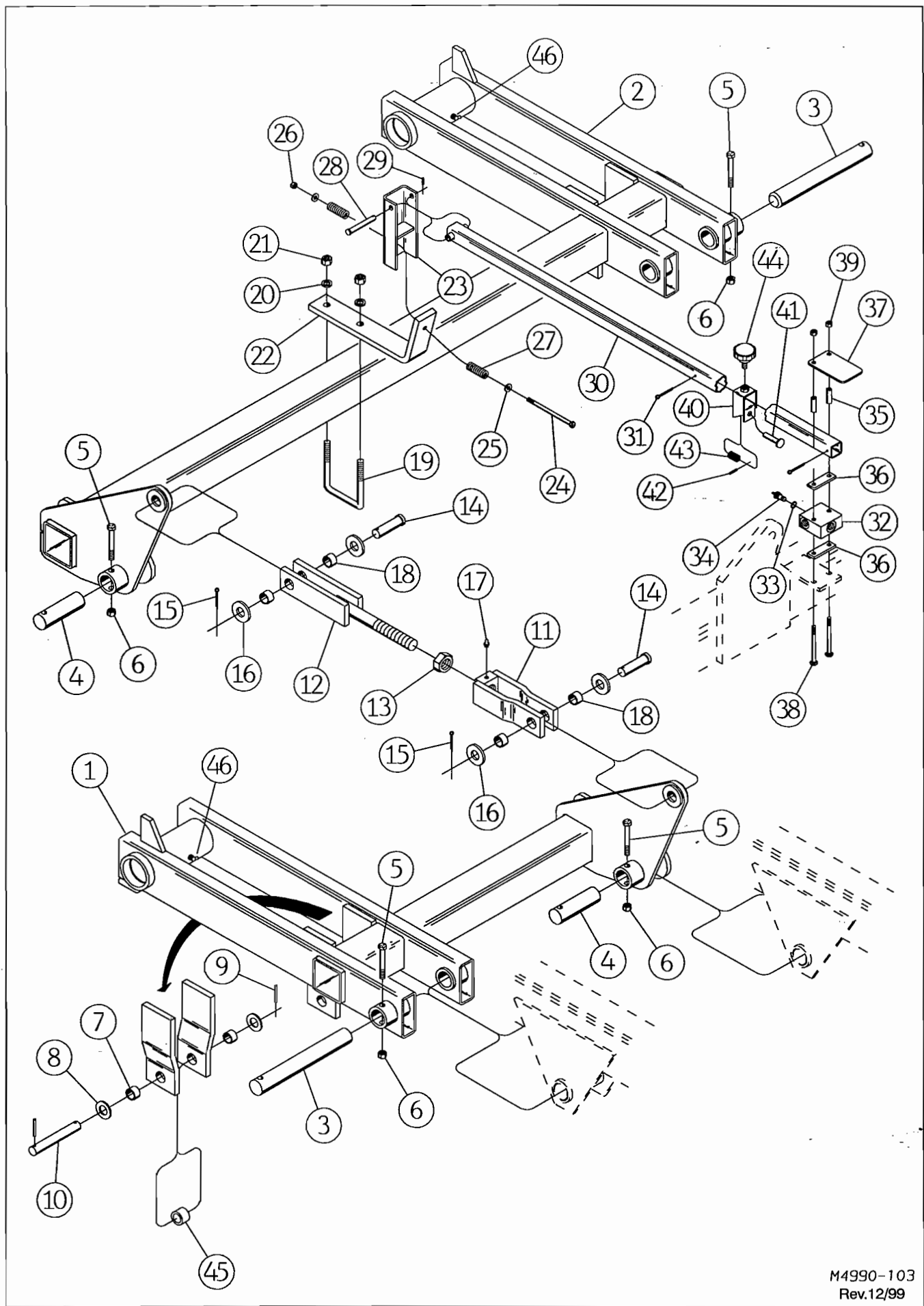

M4990-103
Rev.12/99

MAIN ROCKER ASSEMBLIES

FOR MODELS - ALL

12/99

Item	Part Number	Part Description	Qty.
1	4987-10-0A	Right Basic Rocker Weldment	1
2	4987-11-0A	Left Basic Rocker Weldment	1
3	4987-0-1	Rocker Pivot Pin (1.75 x 12.75")	2
4	4987-0-3	Rocker Pivot Pin (1.75 x 5.50")	2
5	62-154	1/2NC x 3-1/2" GD.5 Cap Screw	4
6	63-107	1/2NC Lock Nut	4
7	53-103	Wear Sleeve	4
8	64-155	1" SAE Flat Washer	4
9	60-606	1/4" DIA. x 2" Roll Pin	4
10	4226-0-4	Cylinder Pin (1" x 6.34")	2
	4956-40-0	Adjustment Link Assembly	1
11	4956-41-0	Link End Weldment	1
12	4956-43-0	Link End Weldment	1
13	63-124	1-1/4NC Hex Jam Nut	1
14	60-249	1" x 3-1/4" Heat Treated Clevis Pin	2
15	60-704	3/16" DIA. x 2" Cotter Pin	2
16	64-119	1" STD. Flat Washer	4
17	65-101	1/8" STD. Zerk	1
18	53-103	Wear Bushing	4
19	61-123	5/8" DIA. U-Bolt	1
20	64-109	5/8" STD. Lock Washer	2
21	63-109	5/8NC Hex Nut	2
22	4987-0-21	Hydraulic Stop Arm	1
23	4987-84-0	Stop Arm Weldment	1
24	62-636	3/8NC x 6" GD.5 Cap Screw	1
25	64-104	3/8" STD. Flat Washer	2
26	63-134	3/8NC Nylon-Top Lock Nut	1
27	76-120	Compression Spring	2
28	60-231	1/2" DIA. x 3-1/2" Clevis Pin	1
29	60-632	5/32" DIA. x 3/4" Roll Pin	1
30	4987-85-0	Stop Linkage Weldment	1
31	60-704	3/16" DIA. x 2" Cotter Pin	2
32	25-2474	Stop Housing Assembly	1
33	25-2476	O-Ring	1
34	25-2475	Cartridge Assembly (Includes Item 33)	1
	4987-69-0	Guide Assembly	1
35	3112-69-1	Valve Spacer	2
36	3112-69-2	Bolt Strap	2
37	3112-69-3	Decal Plate	1
38	62-634	3/8NC x 4-1/2" GD.5 Carriage Bolt	2
39	63-102	3/8NC Lock Nut	2
	6112-91-0	Striker Assembly	1
40	6112-92-0	Striker Weldment	1
41	60-126	Headed Pin	1
42	60-602	3/16" DIA. x 1" Roll Pin	1
43	76-102	Compression Spring	1
44	99-165	Fluted Plastic Knob	1
45	4987-0-22	Spacer	2
46	65-100	1/8NPT x 45° Zerk	2

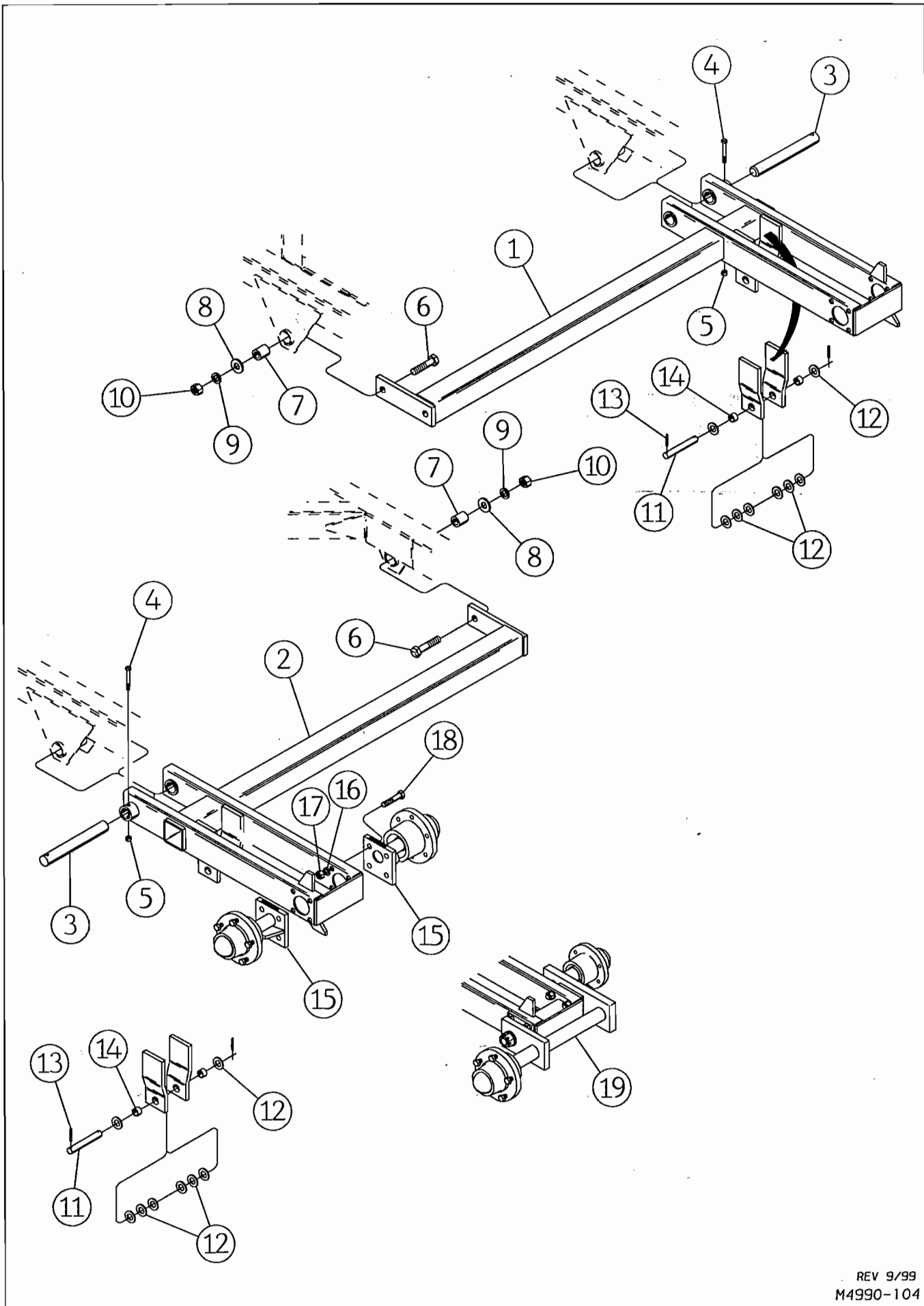

REV 9/99
M4990-104

WING SECTION WALKING BEAM ASSEMBLY

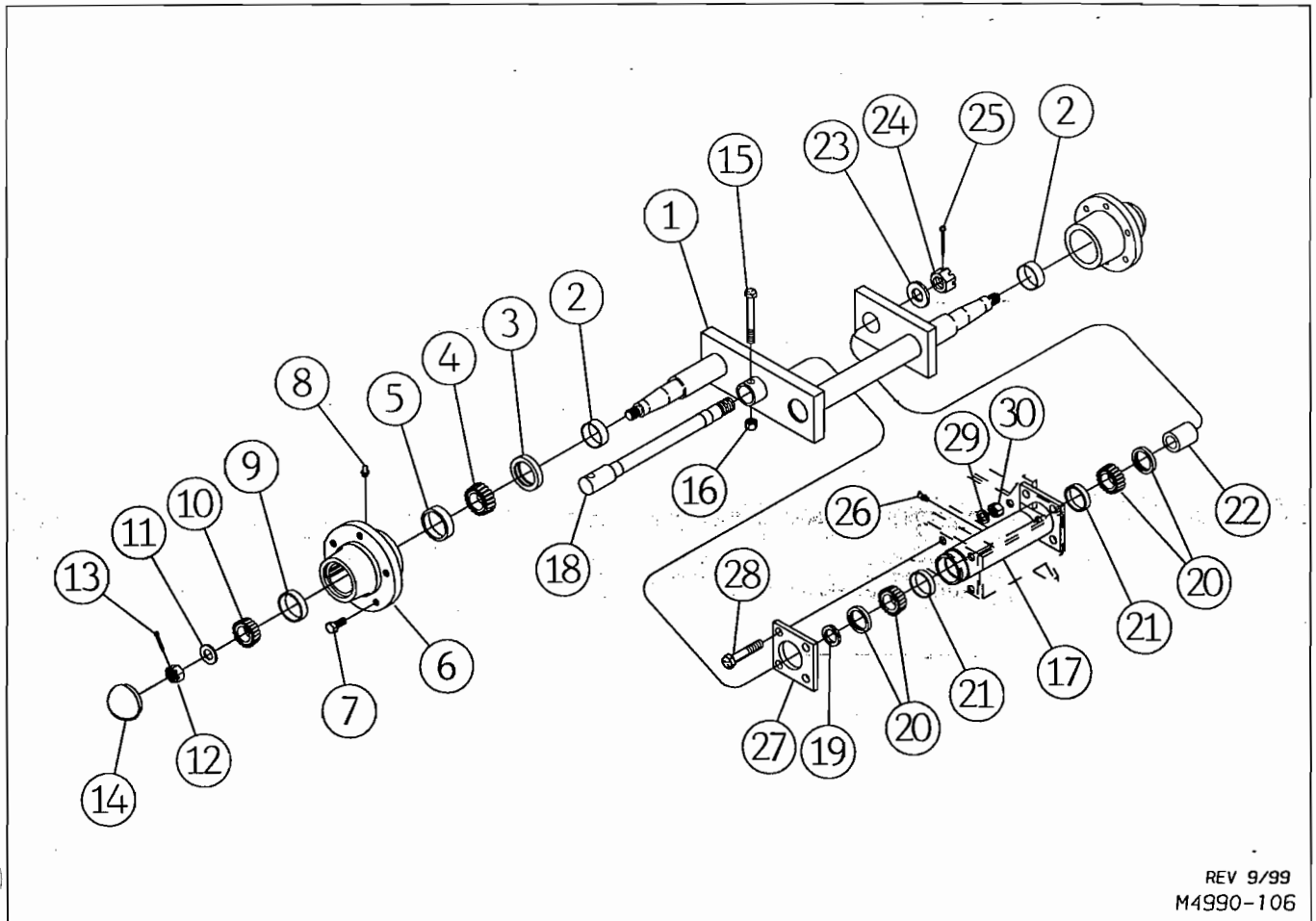

REV 9/99
M4990-106

FOR MODELS - ALL

9/99

Item	Part Number	Part Description	Qty.	Item	Part Number	Part Description	Qty.
1	4987-49-0	Walking Beam Weldment	1	19	4218-13-3	Special Washer	1
2	53-105	Wear Sleeve	2	20	41-121	Cone Assembly	2
3	42-108	Seal	1	21	41-208	Cup	2
4	41-113	Cone	1	22	4987-29-2	Bushing	1
5	41-209	Cup	1	23	64-167	Special Washer	1
6	★ 1918-14-0A	Repair Hub Assembly	1	24	63-231	1-1/4NF Slotted Hex Nut	1
7	62-295	Wheel Bolt	6	25	60-710	1/4"DIA. x 2-1/2" Cotter Pin	1
8	65-122	1/4 x 65 Drive Zerk	2	26	65-100	1/8 x 45 Zerk	1
9	41-208	Cup	1	27	4987-53-2	Plate	1
10	41-112	Cone	1	28	62-199	3/4NC x 3-1/2" GD5 Cap Screw	8
11	64-120	1" SAE Flat Washer	1	29	64-112	3/4" STD. Lock Washer	8
12	63-204	1NF Slotted Hex Nut	1	30	63-112	3/4NC Hex Nut	8
13	60-702	3/16"DIA. x 1-1/2" Cotter Pin	1				
14	52-302	Hub Cap	1	★ Repair Hub includes Items 6, 7, 8, 9 & 10			
15	62-409	5/8NC x 3" GD5 Cap Screw	1				
16	63-110	5/8NC Lock Nut	1				
17	4987-53-0	Walking Beam Hub	1				
18	4987-29-1	Pivot Spindle	1				

WING HUB ASSEMBLY

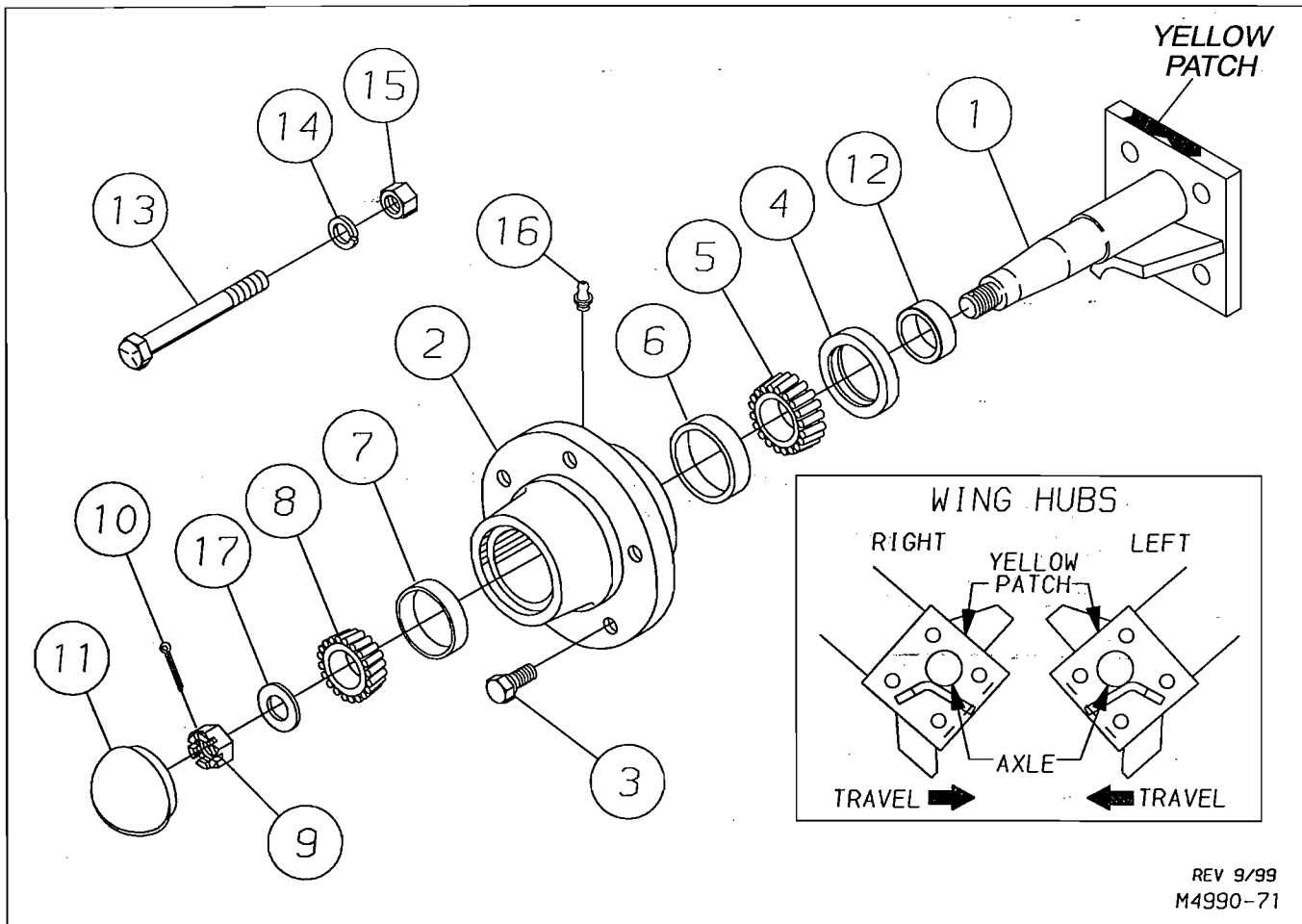

REV 9/99
M4990-71

FOR MODELS - ALL

9/99

Item	Part Number	Part Description	Qty.
	1918-17-0	Hub & Spindle Assembly	1
1	1918-15-0	Repair Spindle and Sleeve Assembly (Includes Items 1 & 12)	
2	1918-14-0A	Repair Hub Assembly (Includes Items 2, 3, 6, 7 & 16)	1
3	62-295	Wheel Bolt	6
4	42-108	Seal	1
5	41-113	Rear Cone	1
6	41-209	Rear Cup	1
7	41-208	Front Cup	1
8	41-112	Front Cone	1
9	63-204	1NF Slotted Hex Nut	1
10	60-702	3/16" DIA. x 1-1/2" Cotter Key	1
11	52-302	Hub Cap	1
12	53-105	Wear Sleeve	1
13	★ 62-199	3/4NC x 3-1/2" GD5 Cap Screw	4
14	★ 64-112	3/4" STD. Lock Washer	8
15	★ 63-112	3/4NC Hex Nut	8
16	65-122	1/4" x 65° Drive Zerk	2
17	64-120	1" SAE Flat Washer	1
	1918-84-0	Hub Bearing Repair Kit (Includes Items 4,5,6,7,8)	
★ Not part of Hub Assembly			

DISC BLADES, WHEELS & TIRES

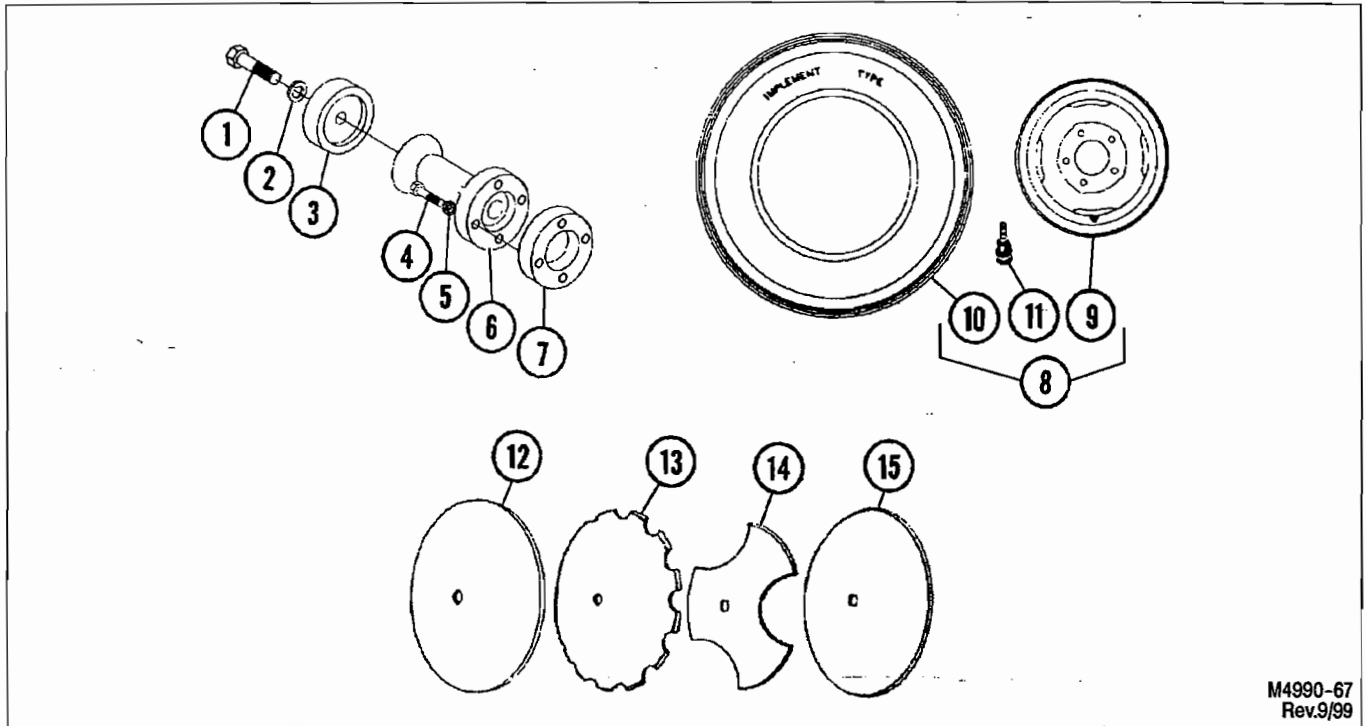

M4990-67
Rev.9/99

FOR MODELS - ALL

12/99

Item	Part Number	Part Description	Qty.
1	62-195	3/4NC x 2-1/2" GD5 Cap Screw	1
2	64-112	3/4" STD. Lock Washer	1
3	611-43-2	Spool Washer	1
4	62-372	1/2NC x 2-1/2" GD5 Cap Screw	4
5	64-107	1/2" STD. Lock Washer	4
6	2212-43-1	Extension Spool	1
7	7400-0-4	Spacer	
8	1000-10580-0	Wheel and Tire Assembly	1
9	52-103	Wheel - 15" x 10"	1
10	51-103	Tire - 10.00 x 15, 8-Ply	1
11	51-107	#415 Valve Stem	1
12	30-223	Disc Blade 22" 7 Ga. Plain Sharp 224517Com-PS	
	30-240	Disc Blade 22" 6 Ga. Plain Sharp 225017Com-PS	
	30-241	Disc Blade 22" 1/4" Plain Sharp 226517Com-PS	
	30-237	Disc Blade 22" 6 Ga. Shallow Concavity	
	30-219	Disc Blade 24" 7 Ga. Plain Sharp 244517Com-PS	
	30-243	Disc Blade 24" 6 Ga. Plain Sharp 245017Com-PS	
	30-220	Disc Blade 24" 1/4" Plain Sharp 246517Com-PS	
	20-238	Disc Blade 24" 6 Ga. Shallow Concavity	
	30-225	Disc Blade 20" 6 Ga. Plain Sharp 205017Com-PS	
	30-235	Disc Blade 18" 7 Ga. Plain Sharp 184517Com-PS	
13	30-242	Disc Blade 22" 1/4" Notched Sharp 226517Com-NS	
	30-221	Disc Blade 24" 1/4" Notched Sharp 246517Com-NS	
	30-226	Disc Blade 20" 6 Ga. Notched Sharp 205017Com-NS	
14	30-148	Disc Blade 16" 7 Ga. Cut Out 164511-NS	
	30-147	Disc Blade 18" 7 Ga. Cut Out 184511-NS	
15	30-100	Disc Blade 16" 7 Ga. Extension (Rock) 164511-PS	
	30-102	Disc Blade 18" 7 Ga. Extension (Rock) 184511-PS	

SPACER SPOOLS

REV 9/99
M4990-108

8" SPACING

9-1/8" SPACING

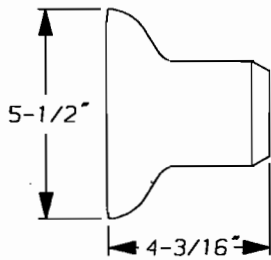

7400-0-8 LONG HALF SPOOL

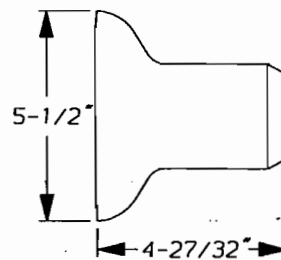

7400-0-9 LONG HALF SPOOL

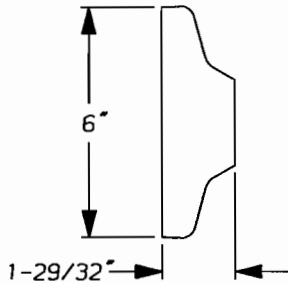

7400-0-11 SHORT HALF SPOOL

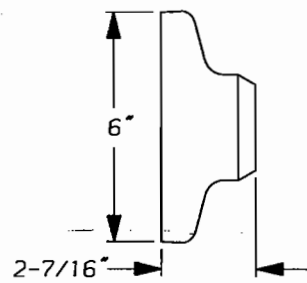

7400-0-10 SHORT HALF SPOOL

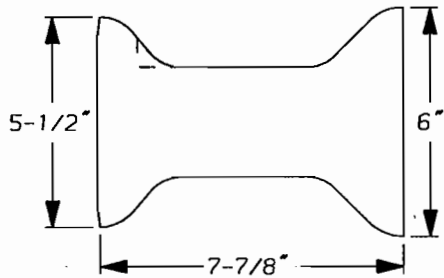

7400-0-6 CAST SPACER SPOOL

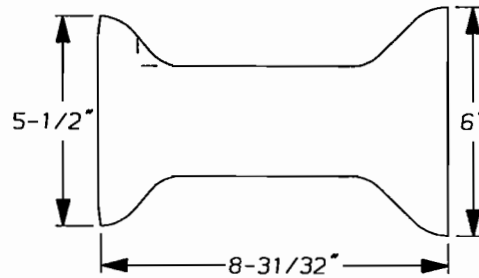

7400-0-7 CAST SPACER SPOOL

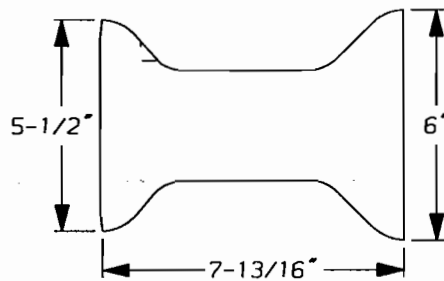

7400-0-12 DUCTILE SPACER SPOOL

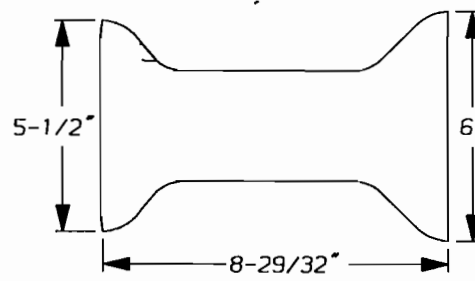

7400-0-5 DUCTILE SPACER SPOOL

7400-0-3
LARGE
END WASHER

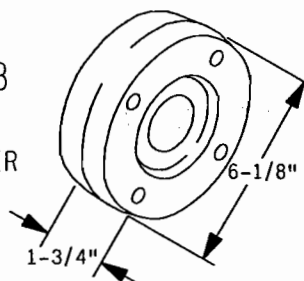

END WASHERS
ALL MODELS

45-107
END WASHER

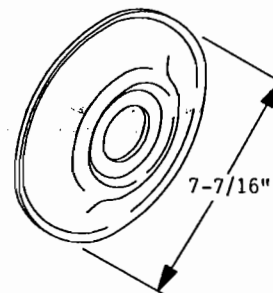

1-3/4" ROUND TIE RODS

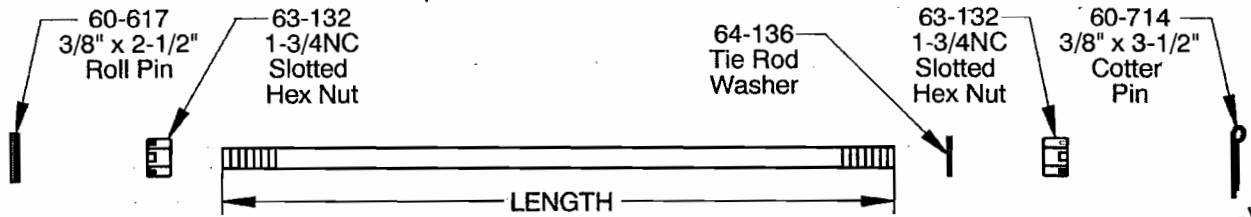

v.9/99

MODEL	LOCATION	Length for 1/4" Blades	DISC SPACING	QTY. DISC	ALLOY TIE ROD	
4995-28N 4995-28NR	Center	Front	78-1/2"	8"	10	4995-0-6
		Rear	70-1/2"	8"	9	4995-0-5
	Wing	Front	86-1/2"	8"	11	1541-20-1
		Rear Inside	46-1/2"	8"	6	2430-18-1
		Rear Outside	46-1/2"	8"	6	2430-18-1
4995-28W 4995-28WR	Center	Front	79-1/2"	9-1/8"	9	4995-0-7
		Rear	70-1/2"	9-1/8"	8	4995-0-5
	Wing	Front	88-5/8"	9-1/8"	10	4995-0-8
		Rear	97-7/8"	9-1/8"	11	4995-0-9
4995-31N 4995-31NR	Center	Front	78-1/2"	8"	10	4995-0-6
		Rear	70-1/2"	8"	9	4995-0-5
	Wing	Front Inside	46-1/2"	8"	6	2430-18-1
		Front Outside	54-5/8"	8"	7	4995-0-2
		Rear Inside	54-5/8"	8"	7	4995-0-2
Rear Outside	54-5/8"	8"	7	4995-0-2		
4995-31W 4995-31WR	Center	Front	79-1/2"	9-1/8"	9	4995-0-7
		Rear	70-1/2"	9-1/8"	8	4995-0-5
	Wing	Front Inside	52-1/8"	9-1/8"	6	4995-0-1
		Front Outside	52-1/8"	9-1/8"	6	4995-0-1
		Rear Inside	52-1/8"	9-1/8"	6	4995-0-1
		Rear Outside	61-3/8"	9-1/8"	7	4995-0-3
4995-34N 4995-34NR	Center	Front	78-1/2"	8"	10	4995-0-6
		Rear	70-1/2"	8"	9	4995-0-5
	Wing	Front Inside	62-5/8"	8"	8	4995-0-4
		Front Outside	62-5/8"	8"	8	4995-0-4
		Rear Inside	70-1/2"	8"	9	4995-0-5
Rear Outside	62-5/8"	8"	8	4995-0-4		
4995-34W 4995-34WR	Center	Front	79-1/2"	9-1/8"	9	4995-0-7
		Rear	70-1/2"	9-1/8"	8	4995-0-5
	Wing	Front Inside	61-3/8"	9-1/8"	7	4995-0-3
		Front Outside	61-3/8"	9-1/8"	7	4995-0-3
		Rear Inside	70-1/2"	9-1/8"	8	4995-0-5
		Rear Outside	61-3/8"	9-1/8"	7	4995-0-3
4995-36W 4995-36WR	Center	Front	79-1/2"	9-1/8"	9	4995-0-7
		Rear	70-1/2"	9-1/8"	8	4995-0-5
	Wing	Front Inside	61-3/8"	9-1/8"	7	4995-0-3
		Front Outside	70-1/2"	9-1/8"	8	4995-0-5
		Rear Inside	61-3/8"	9-1/8"	7	4995-0-3
Rear Outside	79-1/2"	9-1/8"	9	4995-0-7		

RIGID SCRAPERS

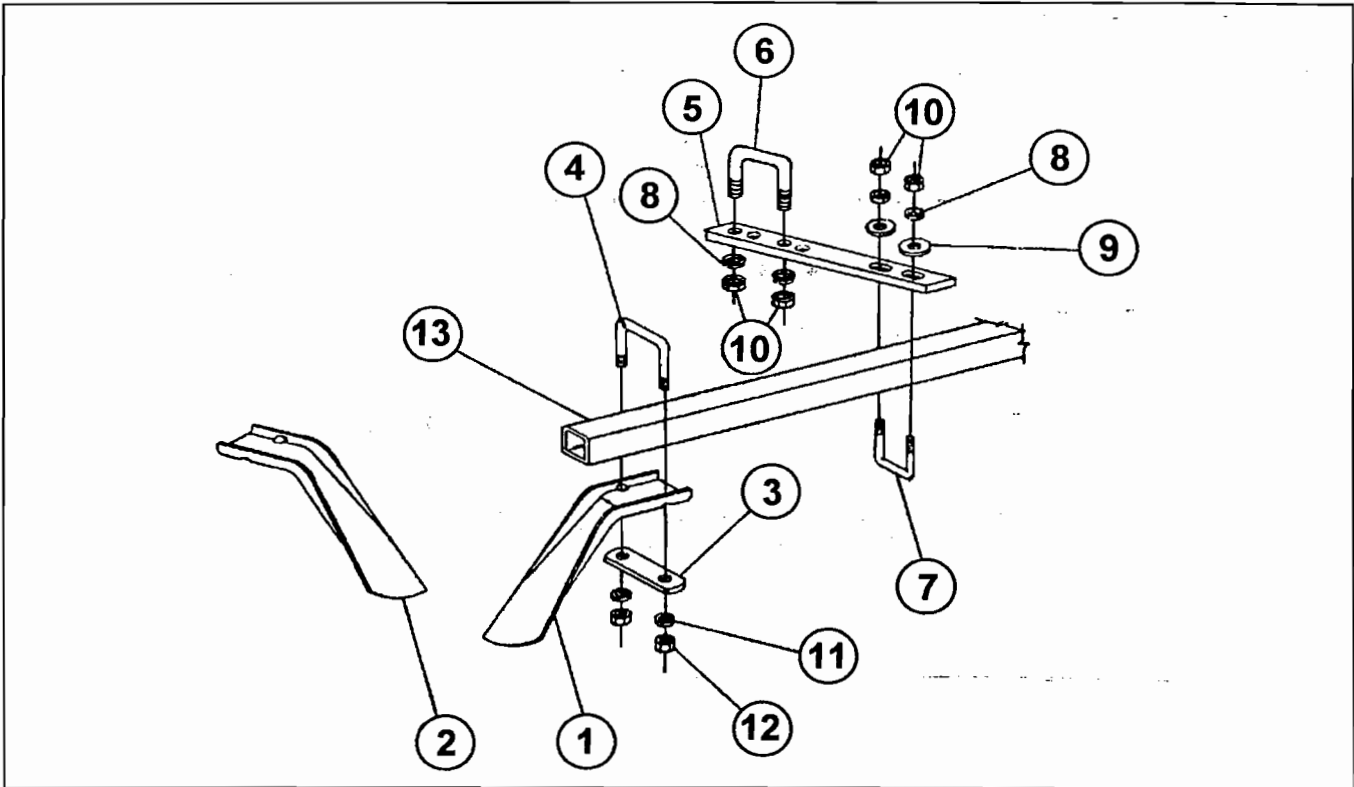

FOR MODELS - ALL

11/96

Item	Part Number	Part Description	Qty.
1	32-115	Left Rear - Right Front Scraper Blade 5"	
2	32-114	Right Rear - Left Front Scraper Blade 5"	
3	4907-186-3	Clamp	
4	61-145	U-Bolt	
5	1901-187-1	Scraper Bracket	
6	61-107	U-Bolt	
7	61-119	U-Bolt	
8	64-109	5/8" STD. Lock Washer	
9	64-110	5/8" STD. Flat Washer	
10	63-109	5/8NC Hex Nut	
11	64-107	1/2" STD. Lock Washer	
12	63-106	1/2NC Hex Nut	
13	★ 2008-1-300	Scraper Bar 30" Long	
	2008-1-385	Scraper Bar 38-1/2" Long	
	2008-1-435	Scraper Bar 43-1/2" Long	
	2008-1-535	Scraper Bar 53-1/2" Long	
	2008-1-585	Scraper Bar 58-1/2" Long	
	2008-1-625	Scraper Bar 62-1/2" Long	
	2008-1-68	Scraper Bar 68" Long	
	2008-1-705	Scraper Bar 70-1/2" Long	
	2008-1-795	Scraper Bar 79-1/2" Long	
	2008-1-875	Scraper Bar 87-1/2" Long	
	2008-1-945	Scraper Bar 94-1/2" Long	
	2008-1-975	Scraper Bar 97-1/2" Long	
	2008-1-104	Scraper Bar 104" Long	
	2008-1-1085	Scraper Bar 108-1/2" Long	
	2008-1-115	Scraper Bar 115" Long	
★ See placement page for correct scraper bar at each location			

DOUBLE SCRAPER ASSEMBLY

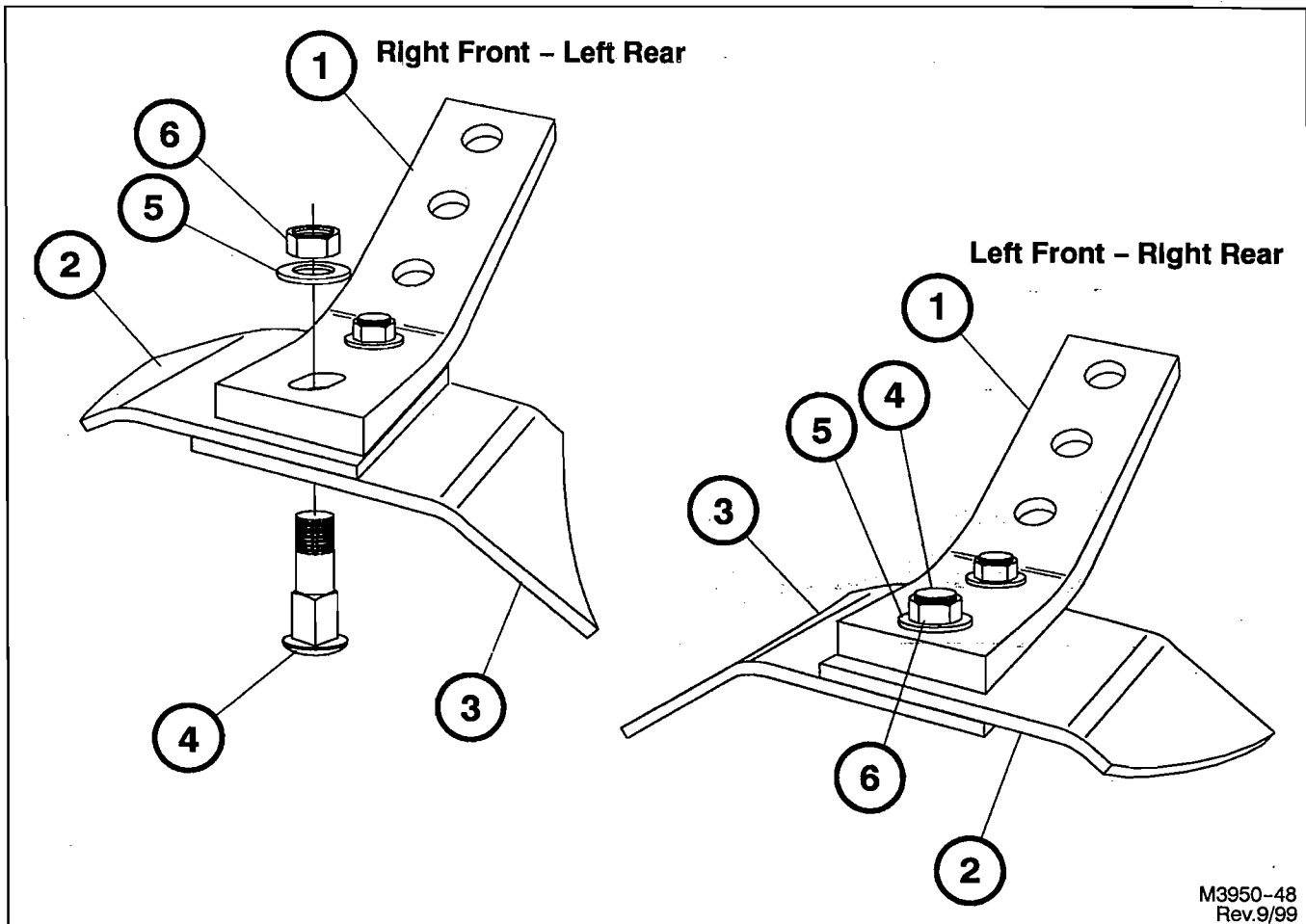

M3950-48
Rev.9/99

FOR MODELS - ALL

9/99

Item	Part Number	Part Description	Qty.
	■ 4950-186-0	Right Front - Left Rear Double Scraper Assembly	1
	● 4950-185-0	Left Front - Right Rear Double Scraper Assembly	1
1	4950-185-1	Bracket	1
2	■ 4950-186-2	Convex Scraper Blade for Right Front - Left Rear Assm.	1
	● 4950-185-2	Convex Scraper Blade for Left Front - Right Rear Assm.	1
3	■ 4950-186-3	Concave Scraper Blade for Right Front - Left Rear Assm.	1
	● 4950-185-3	Concave Scraper Blade for Left Front - Right Rear Assm.	1
4	62-139	1/2NC x 1-3/4" Carriage Bolt	2
5	64-108	1/2" STD. Flat Washer	2
6	63-108	1/2NC Nylon-Top Lock Nut	2

TRAIL HITCH ASSEMBLY

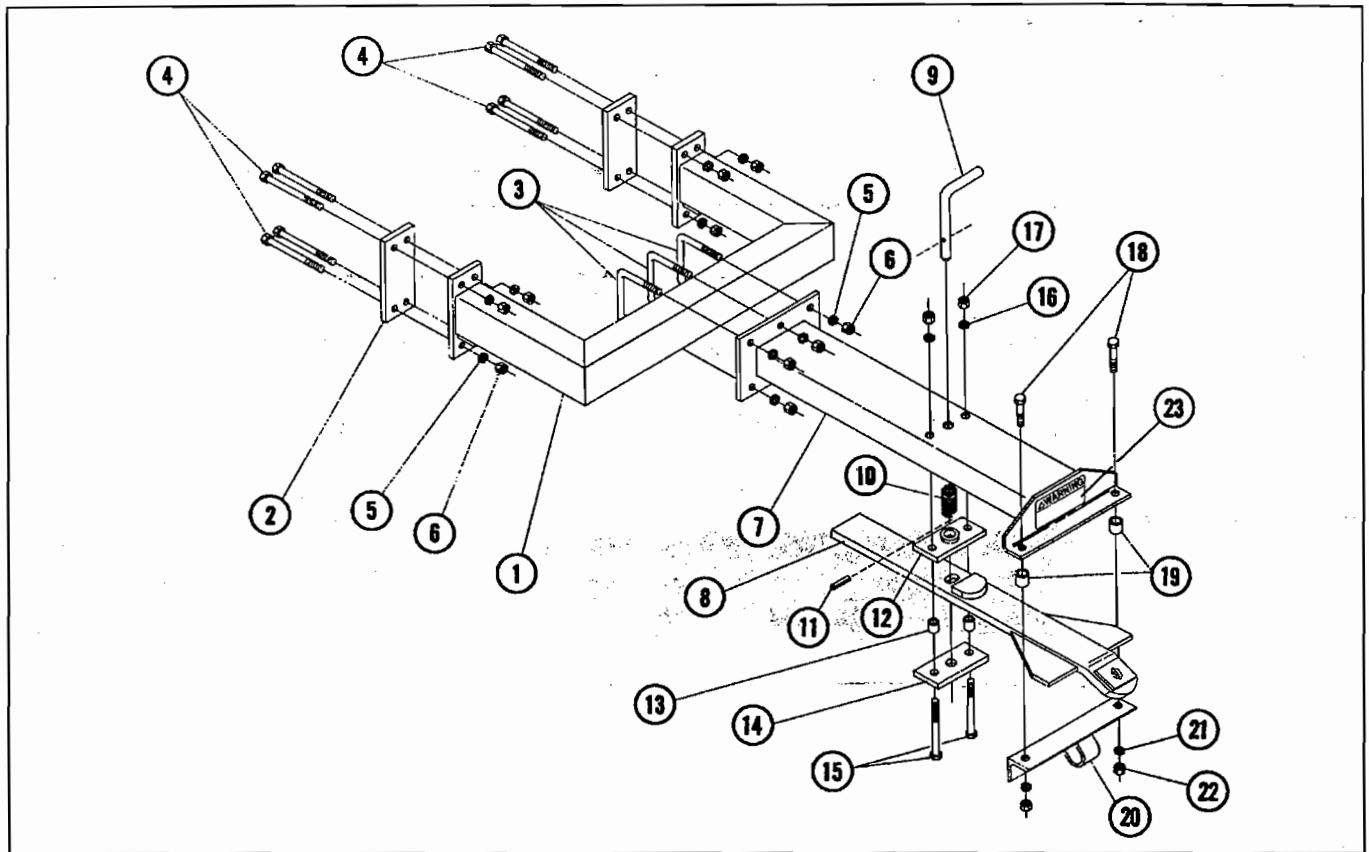

FOR MODELS - ALL

5/97

Item	Part Number	Part Description	Qty.
	2100-311-0	Hitch Extension Assembly	1
1	2100-310-0	Hitch Extension Weldment	1
2	2100-310-2	Bolt Plate	2
3	61-126	5/8" DIA. U-Bolt	3
4	62-330	5/8NC x 6-1/2" GD5 Cap Screw	8
5	64-109	5/8" STD. Lock Washer	14
6	63-109	5/8NC Hex Nut	14
	3755-302-0A	Trail Hitch Assembly	1
7	3755-303-0A	Hitch Frame Weldment	1
8	3755-304-0A	Swing Tongue Weldment	1
9	3755-302-1	Spring Pin	1
10	76-137	Spring	1
11	60-606	1/4" DIA. x 2" Roll Pin	1
12	3755-305-0	Pin Guide Weldment	1
13	3755-302-3	Spacer	2
14	3755-302-2	Pin Guide	1
15	62-393	5/8NC x 6" GD5 Cap Screw	2
16	64-109	5/8" STD. Lock Washer	2
17	63-109	5/8NC Hex Nut	2
18	62-195	3/4NC x 2-1/2" GD5 Cap Screw	2
19	3755-302-4	Spacer	2
20	3755-307-0	Angle Support Weldment	1
21	64-112	3/4" STD. Lock Washer	2
22	63-112	3/4NC Hex Nut	2
23	74-375	WARNING Decal	1

PACKER HITCH

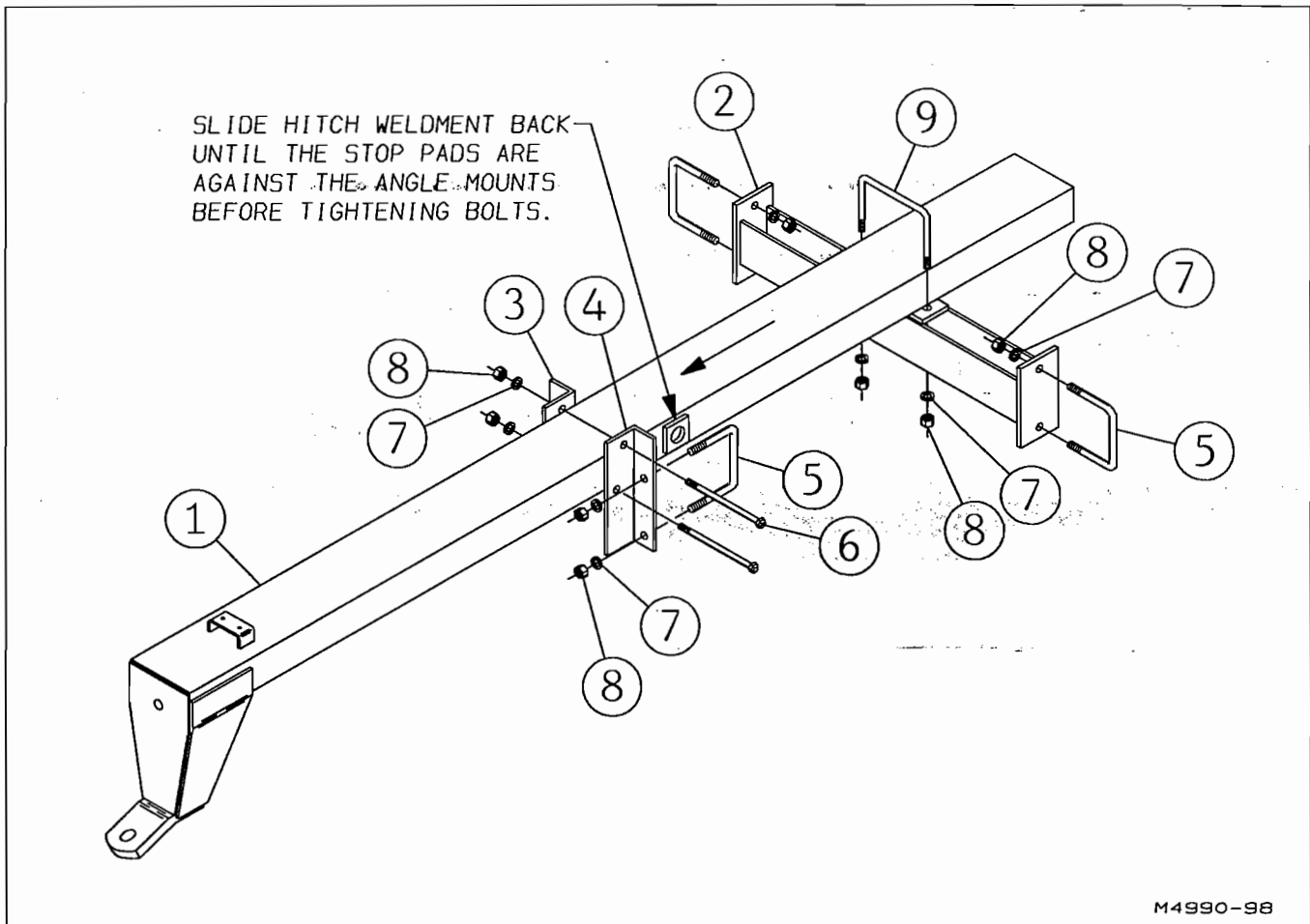

FOR MODELS - ALL

11/96

Item	Part Number	Part Description	Qty.
	4990-313-0	Packer Hitch Group	
1	2490-314-0	Packer Hitch Weldment	1
	4990-315-0	Hitch Mounting Bundle	
2	4990-317-0	Hitch Mount Weldment	1
	4990-316-0	Bolt & Parts Sack (Packer Hitch Mount)	
3	4990-316-1	Left Angle Mount	1
4	4990-316-2	Right Angle Mount	1
5	61-120	3/4"DIA., 6"W, 5-7/8"L U-Bolt	4
6	62-225	3/4NC x 10" GD.5 Hex Machine Bolt	2
7	64-112	3/4" STD. Lock Washer	12
8	63-112	3/4NC Hex Nut	12
9	61-135	3/4"DIA., 8"W, 5-7/8" L U-Bolt	1

GAUGE WHEEL ASSEMBLY -- ACCESSORY

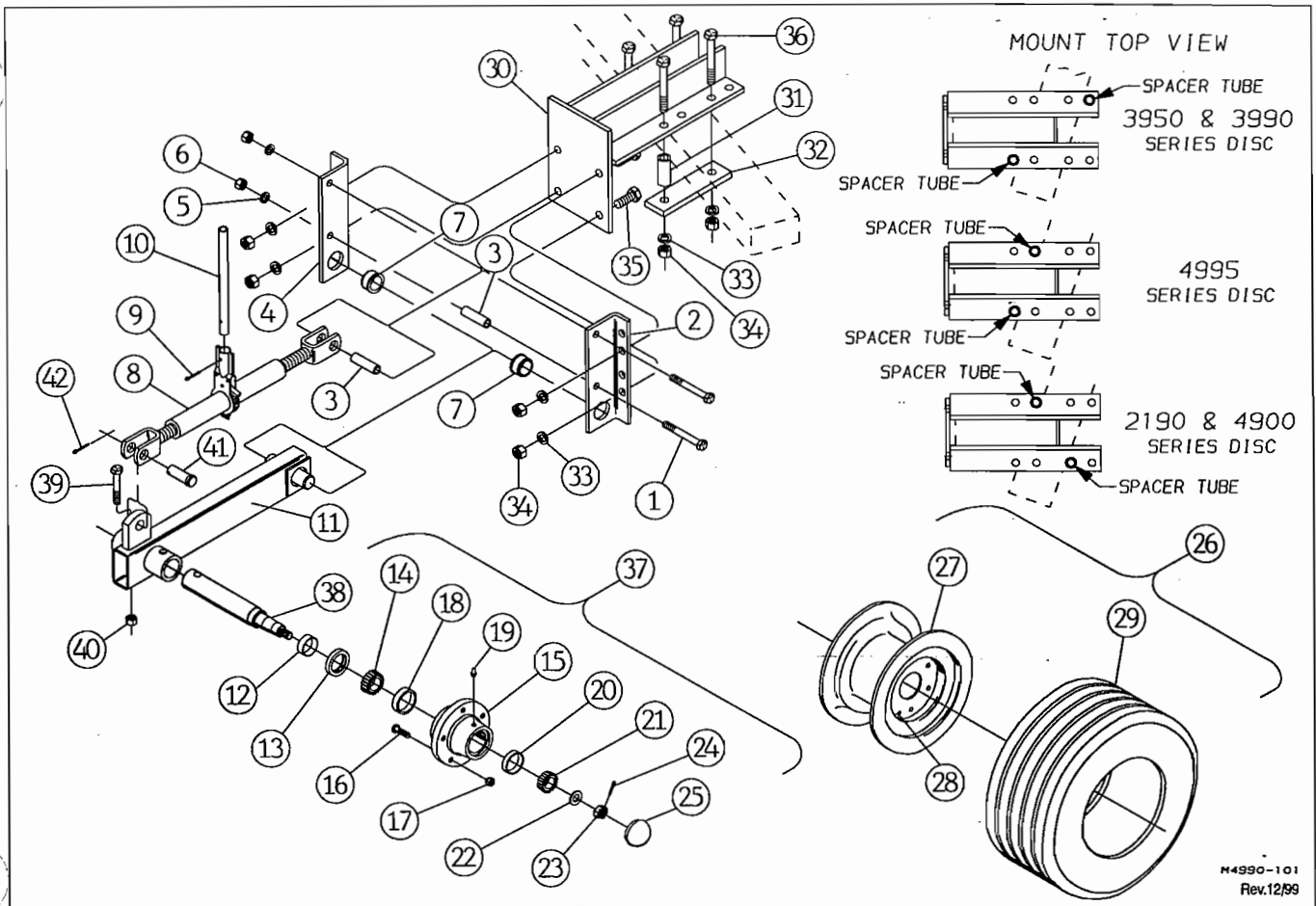

FOR MODELS -

12/00

Item	Part Number	Part Description	Qty.	Item	Part Number	Part Description	Qty.
	2190-49-0	Left Gauge Wheel Assembly		23	63-201	3/4NF Slotted Hex Nut	1
	2190-50-0	Right Gauge Wheel Assembly		24	60-725	5/32" DIA. x 1-1/2" Cotter Pin	1
1	62-339	5/8NC x 4-1/2" GD5 Cap Screw	2	25	52-305	Hub Cap	1
2	2190-51-0	Left Side Plate (includes Item 7)	1	26	●1000-81066-0	Wheel & Tire Assembly	1
3	4000-50-1	Spacer Tube (15/16"DIA. x 3"L)	2	27	52-109	Wheel 10" x 6"	1
4	2190-52-0	Right Side Plate (Includes Item 7)	1	28	51-120	#415 Valve Stem	1
5	64-109	5/8" STD. Lock Washer	2	29	51-121	Tire 20.5 x 8-10, 6-Ply	1
6	63-109	5/8NC Hex Nut	2	30	4990-141-0	Wheel Mount Weldment	1
7	2190-51-1	Bushing (2.125 odx1.52id.1.00)	2	31	4956-0-8	Spacer (1-1/4"D x 2-11/16"Long)	2
8	70-212	Ratchet Jack (includes items 9, 10)	1	32	4990-141-4	Bolt Plate	2
9	60-708	1/4"DIA. x 1-3/4" Cotter Pin	1	33	64-112	3/4" STD. Lock Washer	8
10	70-212-1	7" Jack Handle	1	34	63-112	3/4NC Hex Nut	8
11	2190-53-0	Gauge Wheel Weldment	1	35	62-421	3/4NC x 2" GD5 Cap Screw	4
12	53-111	Wear Sleeve (includes items 11,12)	1	36	62-207	3/4NC x 5-1/2" GD5 Cap Screw	4
13	42-115	Seal (National #470543)	1	37	2190-30-0	Spindle & Hub Assembly	1
14	41-112	Cone (Timken #LM48548)	1	38	2190-29-0	Repair Spindle & Sleeve Assembly	1
15	★ 4990-114-0	Repair Hub Assembly	1	39	62-176	5/8NC x 3-1/2" GD5 Cap Screw	1
16	62-498	1/2NF x 1-7/8" Wheel Bolt	1	40	63-110	5/8NC Lock Nut	1
17	63-209	1/2NF Lug Nut	5	41	60-200	1"DIA. x 2-1/2" Clevis Pin	1
18	41-208	Cup (Timken #LM48510)	1	42	60-703	3/16"DIA. x 1-3/4" Cotter Pin	1
19	65-101	1/8NPT STD. Zerk	1	● Includes Items 27, 28 & 29			
20	41-215	Cup (Timken #LM67010)	1	★ Includes Items 16, 17, 18, 19 & 20			
21	41-117	Cone (Timken #LM67048)	1				
22	64-161	3/4" Hardened Flat Washer	1				

HYDRAULIC HOSE WITH PLASTIC GRIP ASSEMBLIES

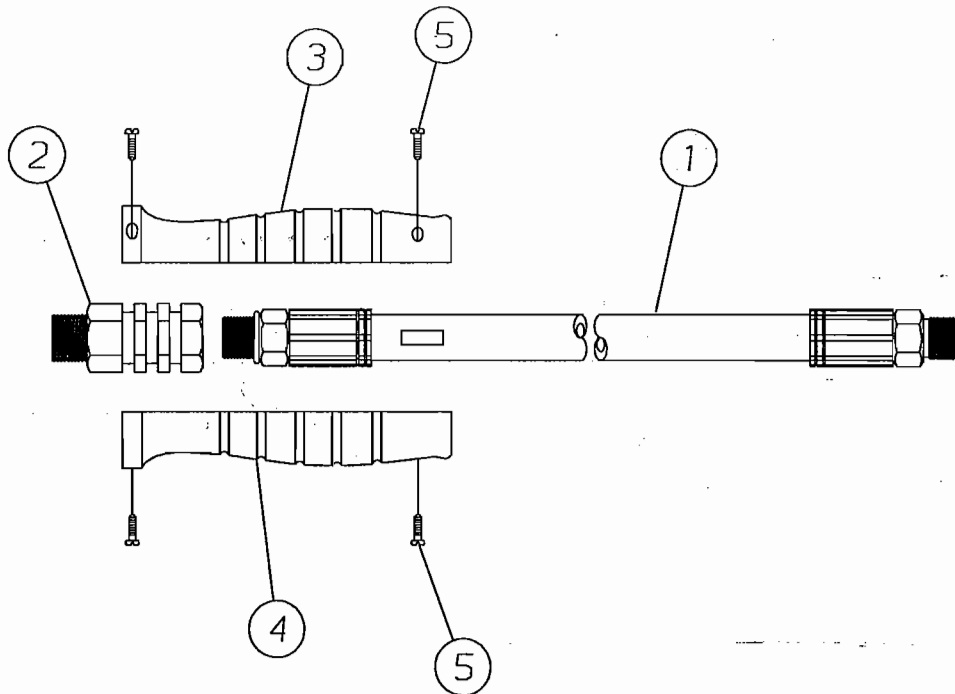

M6100-125
Rev. 5/97

FOR MODELS - ALL

7/97

Item	Part Number	Part Description	Qty.
	4990-75-0	1/2" x 92" 100R2 Hose with Red/Red Grip Assembly	1
1	24-330R	1/2" DIA. x 92" JIC.ORB 100R2 Hose	1
2	25-2295	3/4 ORB to 1/2 NPT Hydraulic Fitting	1
3	25-2289	Hose Grip Half - Red	1
4	25-2289	Hose Grip Half - Red	1
5	62-656	Screw	4
	4990-76-0	1/2" x 92" 100R2 Hose with Yellow/Yellow Grip Assembly	1
1	24-330R	1/2" DIA. x 92" JIC / ORB 100R2 Hose	1
2	24-2295	3/4" ORB to 1/2 NPT Hydraulic Fitting	1
3	25-2290	Hose Grip Half - Yellow	1
4	25-2290	Hose Grip Half - Yellow	1
5	62-656	Screw	4
	4990-77-0	3/8" x 92" 100R2 Hose with Red / Black Grip Assembly	1
1	24-2105R	3/8" DIA. x 92" JIC / ORB 100R2 Hose	1
2	25-2295	3/4" ORB to 1/2 NPT Hydraulic Fitting	1
3	25-2289	Hose Grip Half - Red	1
4	25-2291	Hose Grip Half - Black	1
5	62-656	Screw	4
	4990-78-0	3/8" x 92" 100R2 Hose with Yellow / Black Grip Assembly	1
1	24-2105R	3/8" DIA. x 92" JIC / ORB 100R2 Hose	1
2	25-2295	3/4 ORB to 1/2 NPT Hydraulic Fitting	1
3	25-2290	Hose Grip Half - Yellow	1
4	25-2291	Hose Grip Half - Black	1
5	62-656	Screw	4

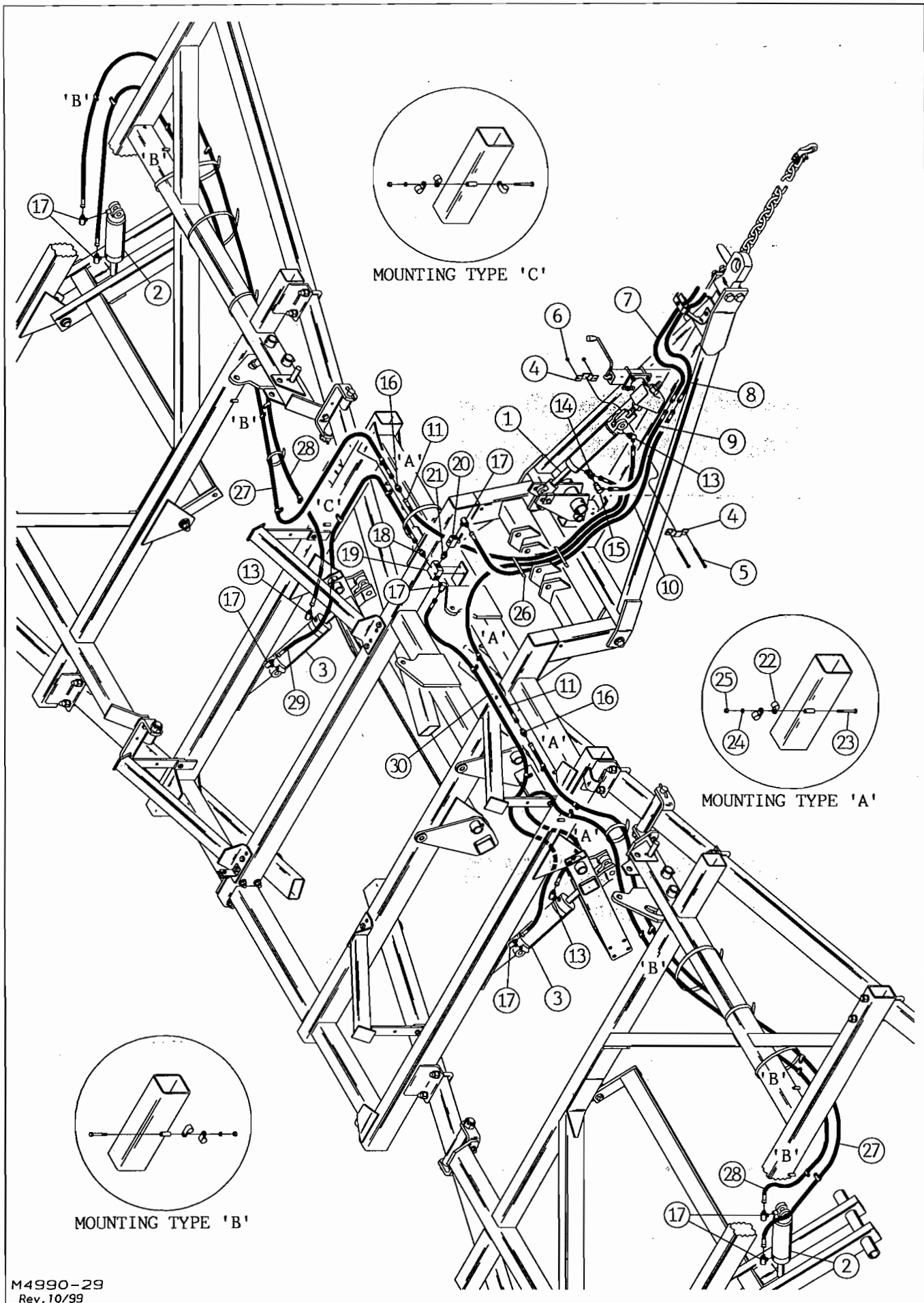

M4990-29
Rev. 10/99

HYDRAULIC HOSE KIT -- DEPTH CONTROL (With Tongue Plumbed In Series)

FOR MODELS - ALL

3/00

Item	Part Number	Part Description	Qty.
1	21-1002	Prince Hydraulic Cylinder 3-3/4" x 8" Series	1
2	21-1003	Prince Hydraulic Cylinder 4" x 8" Series	2
3	21-1004	Prince Hydraulic Cylinder 4-1/4" x 8" Series	2
4	4956-0-14	Hose Clamp	2
5	62-126	3/8NC x 5-1/2" GD5 Cap Screw	2
6	63-103	3/8NC Self Locking Nut	2
7	○ 4990-76-0	Hose Assembly 1/2" x 92" w/ Yellow/Yellow Plastic Handle Grip	1
8	○ 4990-75-0	Hose Assembly 1/2" x 92" w/ Red/Red Plastic Handle Grip	1
9	24-360R	Hose 1/2" x 20" (3/4" Swivel Both Ends)	1
10	24-305R	Hose 1/2" x 55" (3/4" swivel Both Ends)	1
11	24-258R	Hose 3/8" x 94" (3/4" Swivel Both Ends)	2
12			
13	25-312	O-Ring 45° Adapter	3
14	25-302	O-Ring Tee Adapter	1
15	25-310	Male / Female 90° Elbow	1
16	25-304	Male Coupler	2
17	25-301	O-Ring 90° Elbow	8
18	25-300	O-Ring Male Adapter	1
19	◀ 25-2474	Stop Housing Assembly	1
20	25-2265	In-Line Shut-Off Valve Assembly	1
21	25-311	O-Ring Male Coupler	1
22	25-127	3/4" I.D. Hose Clamp	23
23	62-118	3/8NC x 2-1/2" GD5 Cap Screw	11
24	64-103	3/8" STD. Lock Washer	11
25	63-102	3/8NC Hex Nut	11
26	25-126	Panduit Stay Strap	11
27	★ 24-299R	Hose 3/8" x 162" (3/4" Swivel Both Ends)	2
	● 24-297R	Hose 3/8" x 181" (3/4" Swivel Both Ends)	2
	■ 24-238R	Hose 3/8" x 192" (3/4" Swivel Both Ends)	2
28	★ 24-299R	Hose 3/8" x 162" (3/4" Swivel Both Ends)	2
	● 24-281R	Hose 3/8" x 174" (3/4" Swivel Both Ends)	2
	■ 24-233R	Hose 3/8" x 184" (3/4" Swivel Both Ends)	2
29	24-320R	Hose 1/2" x 110" (Black Rubber 100R2)	1
30	24-301R	Hose 1/2" x 113" (Black Rubber 100R2)	1
	★	For 28 Ft. Models ONLY (4995-28N through 4995-28WR)	
	●	For 31 Ft. Models ONLY (4995-31N through 4995-31WR)	
	■	For 34 & 36 Ft. Models (4995-34N through 4995-34WR, 4995-36W & 4995-36WR)	
	○	See page P28 for detailed parts listing	
	◀	See page P8 for detailed parts listing	

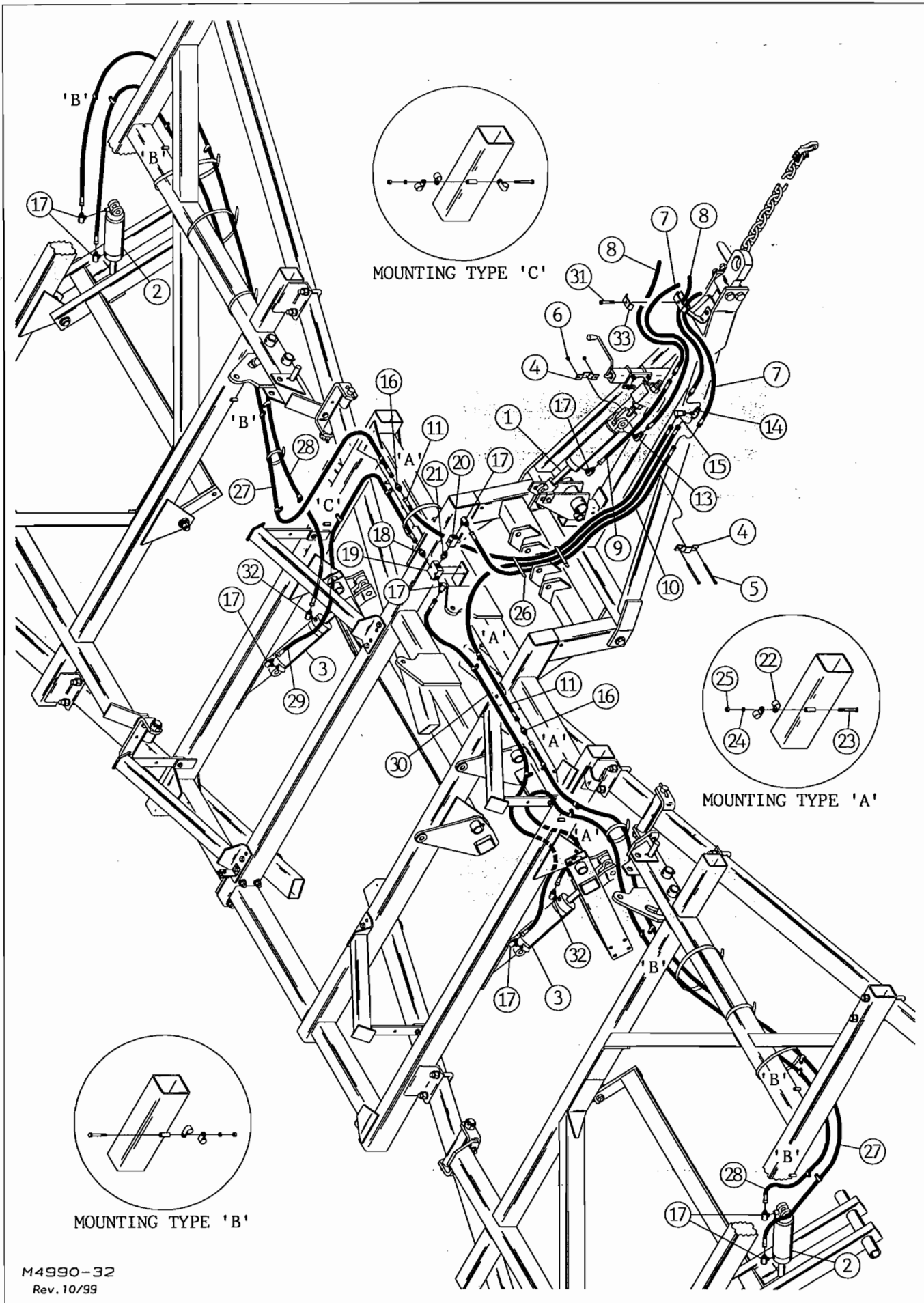

M4990-32
Rev. 10/99

OPTIONAL HYDRAULIC HOSE KIT -- DEPTH CONTROL (With Tongue Plumbed With 3rd Tractor Coupler)

FOR MODELS - ALL

3/00

Item	Part Number	Part Description	Qty.
1	21-1002	Prince Hydraulic Cylinder 3-3/4" x 8" Series	1
2	21-1003	Prince Hydraulic Cylinder 4" x 8" Series	2
3	21-1004	Prince Hydraulic Cylinder 4-1/4" x 8" Series	2
4	4956-0-14	Hose Clamp	2
5	62-126	3/8NC x 5-1/2" GD5 Cap Screw	2
6	63-103	3/8NC Self Locking Nut	2
7	○ 4990-75-0	Hose Assembly 1/2" x 92" w/ Red/Red Plastic Handle Grip	2
8	○ 4990-76-0	Hose Assembly 1/2" x 92" w/ Yellow/Yellow Plastic Handle Grip	2
9	24-360R	Hose 1/2" x 20" (3/4" Swivel Both Ends)	1
10	24-305R	Hose 1/2" x 55" (3/4" swivel Both Ends)	1
11	24-258R	Hose 3/8" x 94" (3/4" Swivel Both Ends)	2
12			
13	25-320	O-Ring 90° Female Elbow	1
14	25-307	Male / Female Tee	1
15	25-310	Male / Female 90° Elbow	1
16	25-304	Male Coupler	2
17	25-301	O-Ring 90° Elbow	9
18	25-300	O-Ring Male Adapter	1
19	◀ 25-2474	Stop Housing Assembly	1
20	25-2265	In-Line Shut-Off Valve Assembly	1
21	25-311	O-Ring Male Coupler	1
22	25-127	3/4" I.D. Hose Clamp	23
23	62-118	3/8NC x 2-1/2" GD5 Cap Screw	11
24	64-103	3/8" STD. Lock Washer	11
25	63-102	3/8NC Hex Nut	11
26	25-126	Panduit Stay Strap	11
27	★ 24-299R	Hose 3/8" x 162" (3/4" Swivel Both Ends)	2
	● 24-297R	Hose 3/8" x 181" (3/4" Swivel Both Ends)	2
	■ 24-238R	Hose 3/8" x 192" (3/4" Swivel Both Ends)	2
28	★ 24-299R	Hose 3/8" x 162" (3/4" Swivel Both Ends)	2
	● 24-281R	Hose 3/8" x 174" (3/4" Swivel Both Ends)	2
	■ 24-233R	Hose 3/8" x 184" (3/4" Swivel Both Ends)	2
29	24-320R	Hose 1/2" x 110" (Black Rubber 100R2)	1
30	24-301R	Hose 1/2" x 113" (Black Rubber 100R2)	1
31	62-151	1/2NC x 3" GD5 Cap Screw	1
32	25-312	O-Ring 45° Adapter	2
33	3514-0-2	Hose Clamp	1
	★	For 28 Ft. Models ONLY (4995-28N through 4995-28WR)	
	●	For 31 Ft. Models ONLY (4995-31N through 4995-31WR)	
	■	For 34 Ft. Model ONLY (4995-34N through 4995-34WR)	
	○	See page P28 for detailed parts listing	
	◀	See page P8 for detailed parts listing	

PRINCE HYDRAULIC CYLINDER

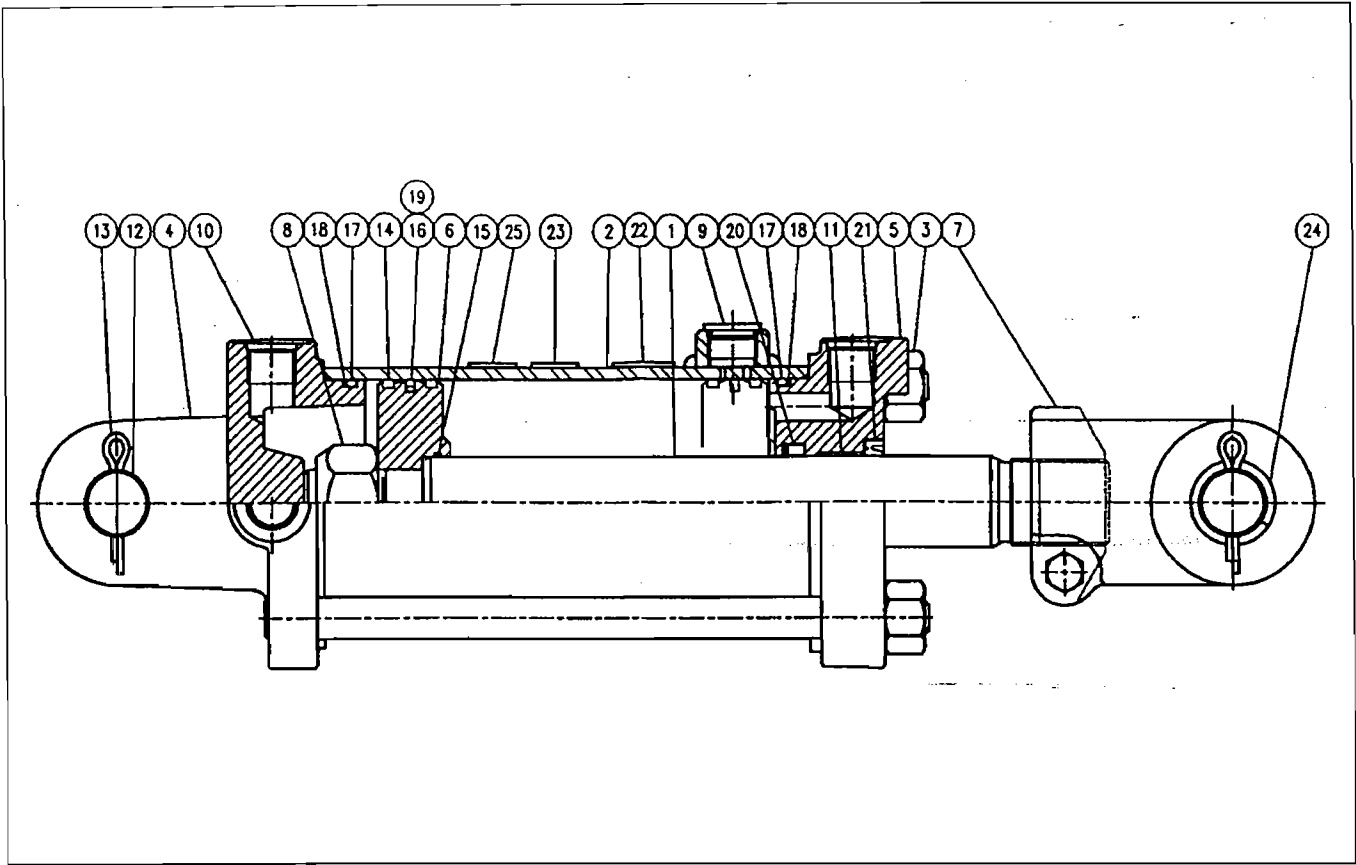

21-1002 3-3/4" X 8" PRINCE HYDRAULIC CYLINDER ASSEMBLY (Series) 12/00
Retracted - 20-1/4" Extended - 28-1/4" Stroke - 8" Rod Diameter - 1-3/8"

Item	Part Number	Part Description	Qty.
1	21-2101	Piston Rod	1
2	21-2104	Tube Assembly	1
3	21-272	Tie Rod Assembly	4
4	21-2105	Butt	1
5	21-803	Gland Assembly	1
6	21-804	Piston	1
7	21-2126	Clevis Assembly	1
8	21-225	Lock Nut	1
9	21-702	Port Plug	1
10	21-404	Port Plug	3
11	21-807	Bushing	1
12	21-260	Clevis Pin	2
13		3/16" DIA. x 1-3/4" Cotter Pin	4
14	★	Bearing Ring	2
15	★	O-Ring	1
16	★	O-Ring	1
17	★	O-Ring	2
18	★	Back-Up Washer	2
19	★	Teflon Seal	1
20	★	U-Cup	1
21	★	Wiper	1
22	21-443	Series Caution Decal	1
23	21-2114	Seal Kit Decal	1
24	21-2127	Bushing	2
25	74-113	Cylinder WARNING Decal	1
	21-808	Seal Kit (★ Items Included in Kit)	

PRINCE HYDRAULIC CYLINDER

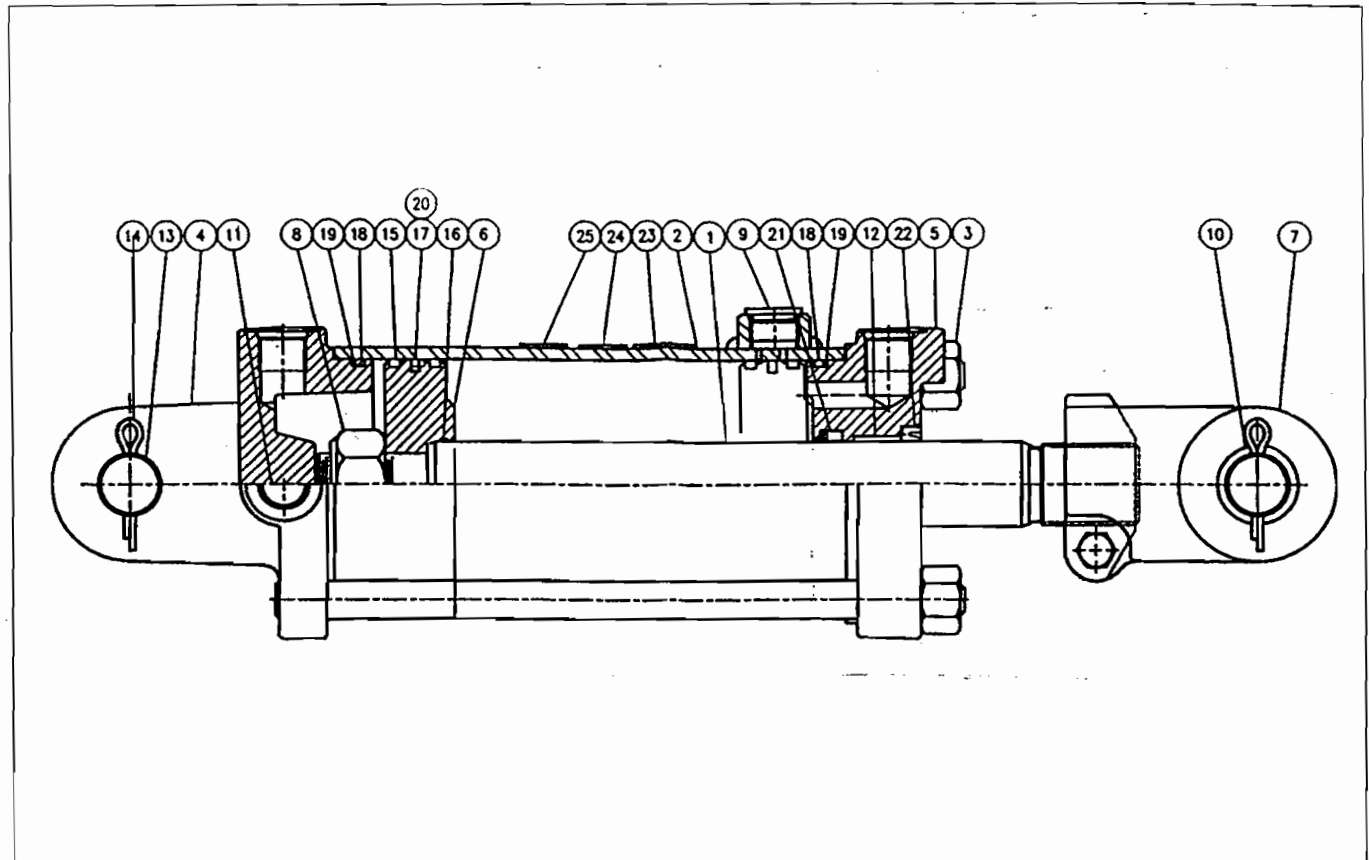

21-1003 4" X 8" PRINCE HYDRAULIC CYLINDER ASSEMBLY (Series) 12/00
Retracted - 20-1/4" Extended - 28-1/4" Stroke - 8" Rod Diameter - 1-3/8"

Item	Part Number	Part Description	Qty.
1	21-2101	Piston Rod	1
2	21-2102	Tube Assembly	1
3	21-396	Tie Rod Assembly	4
4	21-882	Butt	1
5	21-810	Gland Assembly	1
6	21-811	Piston	1
7	21-2126	Clevis Assembly	1
8	21-225	Lock Nut	1
9	21-702	Port Plug	1
10	21-807	Bushing	1
11	21-404	Port Plug	3
12	21-2127	Bushing	2
13	21-260	Clevis Pin	2
14		3/16" DIA. x 1-3/4" Cotter Pin	4
15	★	Bearing Ring	2
16	★	O-Ring	1
17	★	O-Ring	1
18	★	O-Ring	2
19	★	Back-Up Washer	2
20	★	Teflon Seal	1
21	★	U-Cup	1
22	★	Wiper	1
23	21-443	Series Caution Decal	1
24	21-2115	Seal Kit Decal	1
25	74-113	Cylinder WARNING Decal	1
	21-2059	Seal Kit (★ Items Included in Kit)	

PRINCE HYDRAULIC CYLINDER

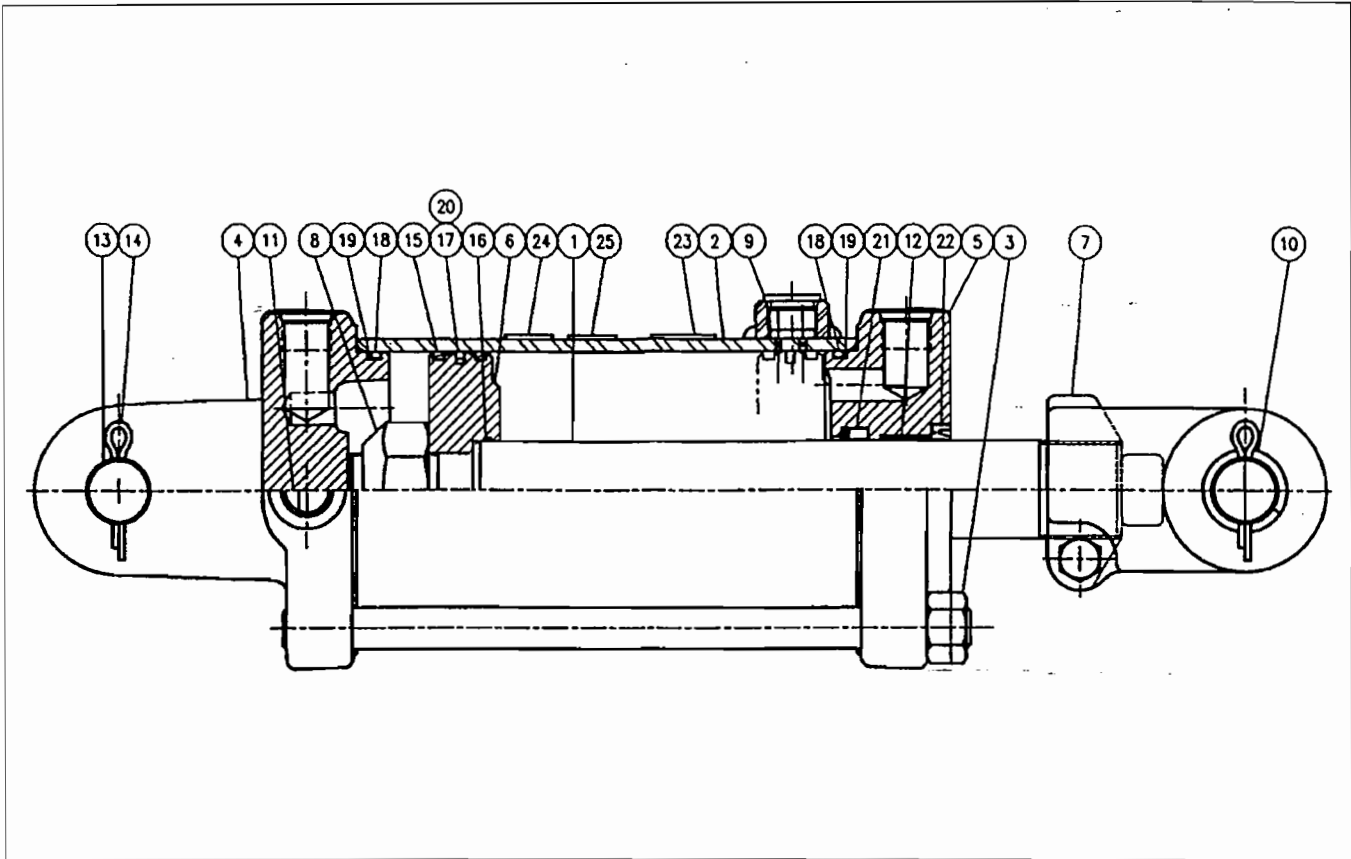

21-1004 4-1/4" X 8" PRINCE HYDRAULIC CYLINDER ASSEMBLY (Series) 12/00
Retracted - 20-1/4" Extended - 28-1/4" Stroke - 8" Rod Diameter - 1-1/2"

Item	Part Number	Part Description	Qty.
1	21-2062	Piston Rod	1
2	21-2065	Tube Assembly	1
3	21-381	Tie Rod Assembly	4
4	21-2072	Butt	1
5	21-2073	Gland	1
6	21-2074	Piston	1
7	21-2125	Clevis Assembly	1
8	21-819	Lock Nut	1
9	21-702	Port Plug	1
10	21-2127	Bushing	2
11	21-404	Port Plug	3
12	21-2069	Bushing	1
13	21-260	Clevis Pin	2
14		3/16" DIA. x 1-3/4" Cotter Pin	4
15	★	Bearing Ring	2
16	★	O-Ring	1
17	★	O-Ring	1
18	★	O-Ring	2
19	★	Back-Up Washer	2
20	★	Teflon Seal	1
21	★	U-Cup	1
22	★	Wiper	1
23	21-443	Series Caution Decal	1
24	21-2116	Seal Kit Decal	1
25	74-113	Cylinder WARNING Decal	1
	21-2060	Seal Kit (★ Items Included in Kit)	

PRINCE HYDRAULIC CYLINDER

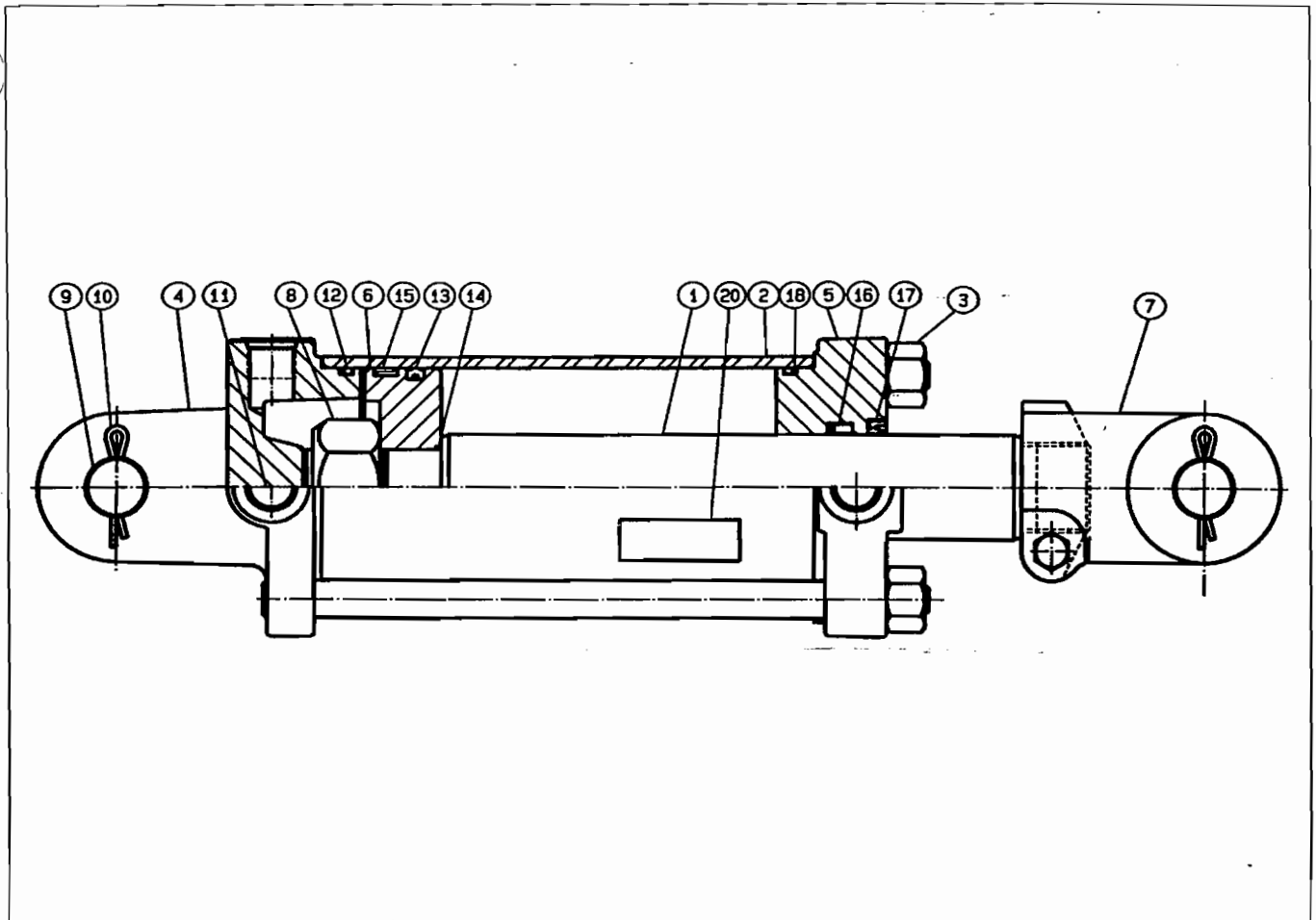

21-186 4" X 8" PRINCE HYDRAULIC CYLINDER ASSEMBLY (STD) 12/00
Retracted - 20-1/4" Stroke - 8" Extended - 28-1/4" Rod Diameter - 1-3/4"

Item	Part Number	Part Description	Qty.
1	21-902	Piston Rod	1
2	21-256	Tube	1
3	21-272	Tie Rod Assembly	4
4	21-337	Butt	1
5	21-878	Gland	1
6	21-879	Piston	1
7	21-506	Clevis Assembly	1
8	21-286	Lock Nut	1
9	21-908	Clevis Pin	2
10		3/16" DIA. x 1-3/4" Cotter Pin	4
11	21-404	Port Plug	3
12	★	O-Ring	2
13	★	Crown Seal	1
14	★	O-Ring	1
15	★	Bearing Ring	1
16	★	U-Cup	1
17	★	Wiper	1
18	★	Back-Up Washer	2
19			
20	74-113	Cylinder Warning Decal	1
	● 21-857	Seal Kit (★ Items Included in Kit)	
	●	Not Included in Cylinder Assembly	

PRINCE HYDRAULIC CYLINDER

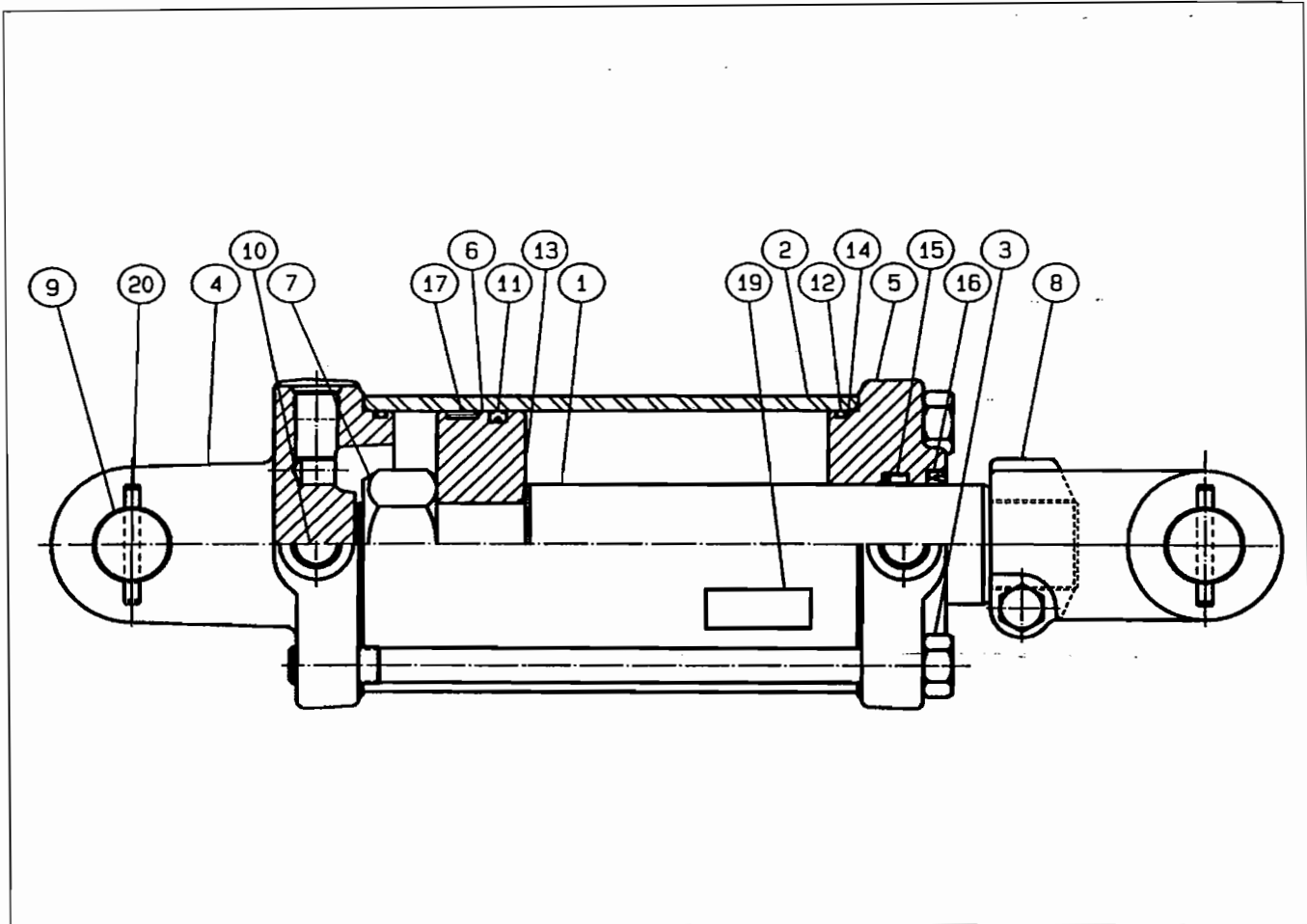

21-188 4-1/2" X 40" PRINCE HYDRAULIC CYLINDER ASSEMBLY (STD) 12/00
Retracted - 52-3/4" Stroke - 40" Extended - 92-3/4" Rod Diameter - 2"

Item	Part Number	Part Description	Qty.
1	21-922	Piston Rod	1
2	21-923	Tube	1
3	21-970	Tie Rod Assembly	4
4	21-887	Butt	1
5	21-888	Gland	1
6	21-889	Piston	1
7	21-890	Lock Nut	1
8	21-685	Clevis Assembly	1
9	21-859	Clevis Pin	2
10	21-404	Port Plug	3
11	★	Crown Seal	1
12	★	O-Ring	2
13	★	O-Ring	1
14	★	Back-Up Washer	2
15	★	U-Cup	1
16	★	Wiper	1
17	★	Bearing Ring	1
18			
19	74-113	Cylinder Warning Decal	1
20		1/4" DIA. x 2" Roll Pin	4
	● 21-892	Seal Kit (★ Items Included in Kit)	
	●	Not Included in Cylinder Assembly	

DECALS & REFLECTORS

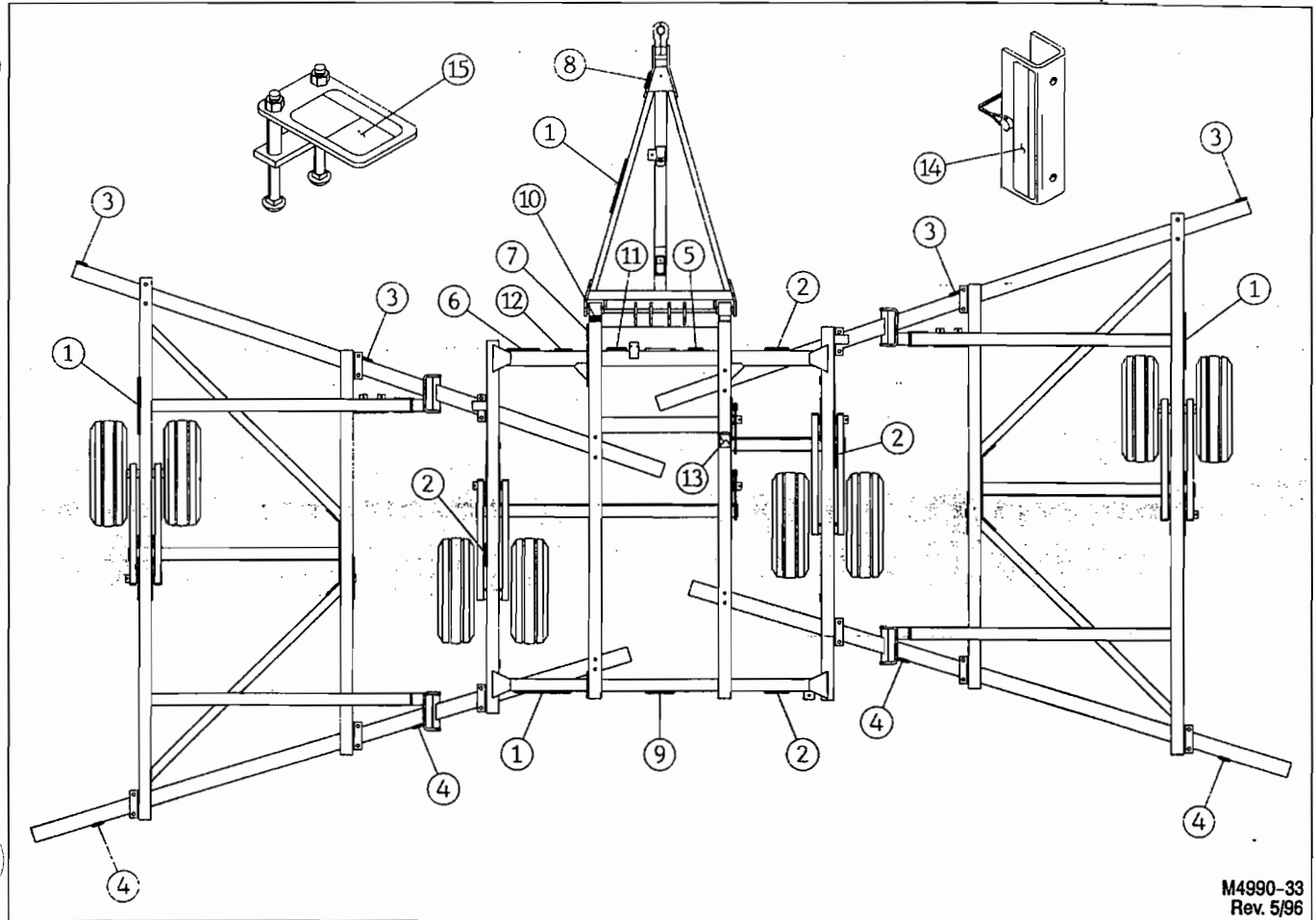

M4990-33
Rev. 5/96

FOR MODELS - ALL

9/99

Item	Part Number	Part Description	Qty.
1	74-100	KRAUSE Decal	4
2	74-102	DANGER - Stand Clear of Wing Decal	4
3	74-107	Amber Reflector	4
4	74-108	Red Reflector	4
5	74-115	Name Plate	1
6	74-117	Implement Safety Decal	1
7	74-121	Width - Height Decal	1
8	74-128	Patent Decal	1
9	74-521	4995 SERIES Decal	1
10	74-155	Adjustment Screw Decal	1
11	74-384	WARNING - Lock Up Valve Decal	1
12	74-276	WARNING - High Pressure Decal	1
13	74-395	IMPORTANT - Timing Link Decal	1
14	74-387	WARNING - Cylinder Lock Decal	2
15	74-348	WARNING - Pinch Point Decal	1

2100-170-0 LIGHT KIT

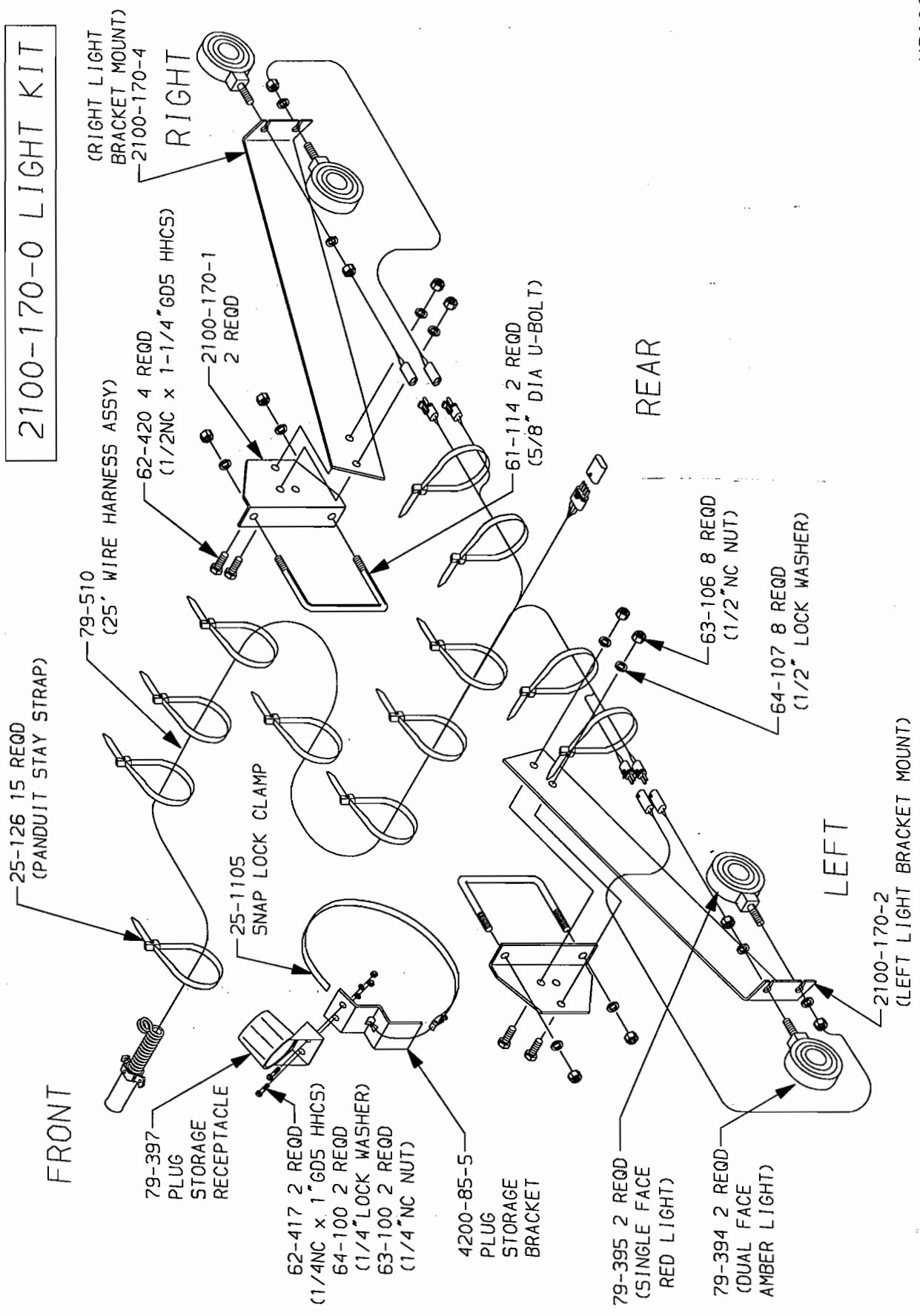

M2100-9
Rev. 9/99

ASSEMBLY SECTION

THE FOLLOWING SECTION ILLUSTRATES A GENERAL METHOD FOR THE ASSEMBLY OF THIS SERIES KRAUSE TILLAGE TOOL. YOU MUST KNOW THE MODEL NUMBER OF THE UNIT BEING ASSEMBLED WHENEVER MAKING REFERENCE TO THIS SECTION. THE FOLLOWING PICTURES AND DRAWINGS WILL SHOW BOLTS, PINS, NUTS AND ETC., WITH THE DESCRIPTIVE SIZE AND LENGTHS IN THE ACCOMPANYING PARAGRAPH AND A PARTS LISTING REFERENCE PAGE NUMBER. IF ANY DIFFICULTY SHOULD BE ENCOUNTERED DURING THE ASSEMBLY, RECHECK THE ILLUSTRATIONS, ASSEMBLY STEPS AND PARTS LIST DRAWINGS.

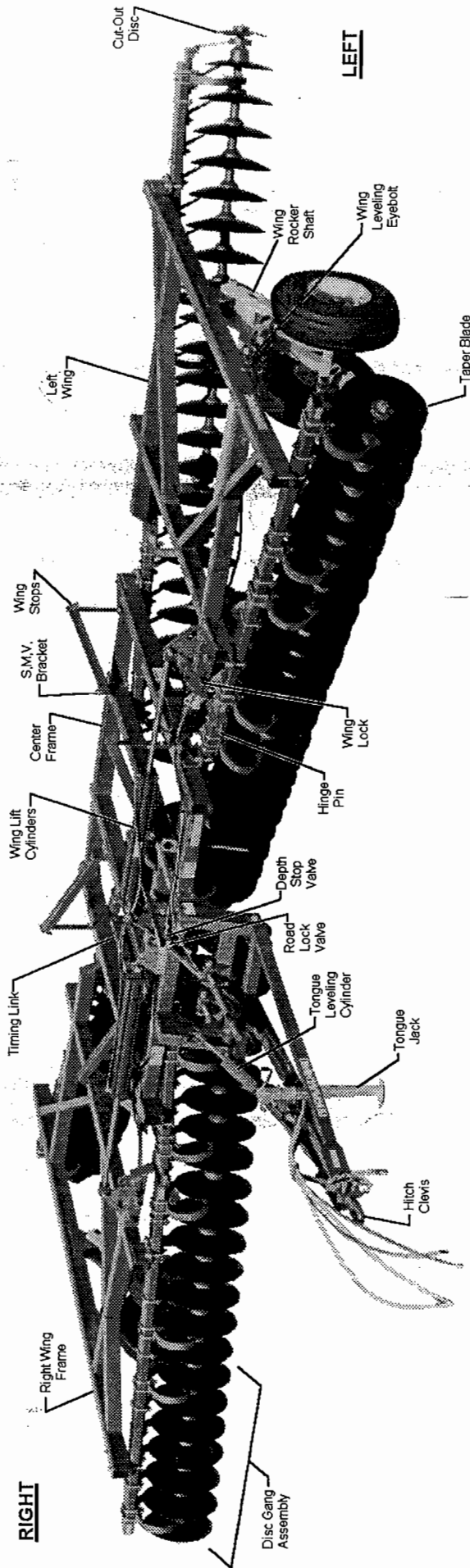

RIGHT

LEFT

ASSEMBLY INSTRUCTIONS

STUDY THE NAMES AND LOCATIONS OF THE PARTS AND FAMILIARIZE YOURSELF WITH THE FLEX WING DISC BEFORE STARTING THE ASSEMBLY. READING THE STEP BY STEP INSTRUCTIONS THAT FOLLOW WILL BE HELPFUL.

SAFETY



READ ALL OF THE SAFETY NOTATIONS IN THE ASSEMBLY INSTRUCTIONS FOR YOUR OWN PROTECTION. ACCIDENTS CAN BE PREVENTED BY RECOGNIZING THE CAUSE OF AN ACCIDENT BEFORE IT CAN HAPPEN.

ASSEMBLY

Select an area for the assembly that will be large enough to accommodate the completed flex wing disc. The surface of the work area should be as level as possible. Use the proper hand tools to insure proper bolt tightness. Refer to the page entitled "Proper Bolt Use" for the recommended torque values of different size bolts.

PART LOCATIONS

FRONT - The front of the frame can be determined by the location of the name plate that has been attached to the front frame member.

RIGHT and **LEFT** sides can be established by standing behind the frame looking toward the front, or the direction of travel.

TOP - To be sure that the frame is right side up, position the frame with the wing lift hydraulic cylinder lugs on top.

⚠ Warning: Always attach chains securely. If a chain would break, the recoil action could cause the loose end to whip in any direction and injure any person nearby. The proof load rating of chain must equal or exceed 5 times the weight being lifted.

THE HEAVIEST COMPONENT TO BE LIFTED INTO PLACE IS THE CENTER FRAME ASSEMBLY WHICH WEIGHS 1,575 LBS.

MODEL NUMBER

Know the model number of the disc being assembled. Use the model number whenever referring to the assembly, parts pages or the placement drawings. The number is stamped on the NAME PLATE which is located on the front frame member of the flex wing tandem disc.



I. CENTER FRAME HALVES (Bolt Sack 66-854)

1. Place the two center frame halves on the ground opposing each other.
2. Bolt them together as shown below.
3. Tighten bolts after assembly.

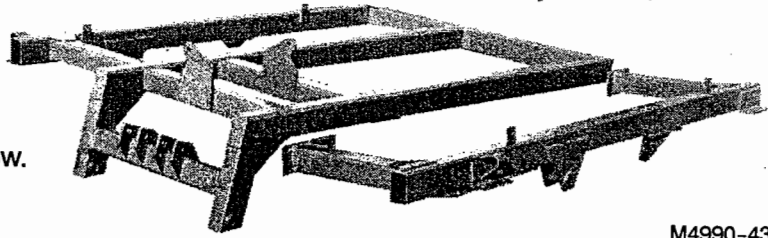

M4990-43

66-854 (CENTER FRAME SACK OF FASTENERS)

- (8) 3/4" NC X 6 GD5 BOLTS
- (8) 3/4" FLAT WASHERS
- (8) 3/4" LOCK WASHERS
- (8) 3/4" NC HEX NUTS

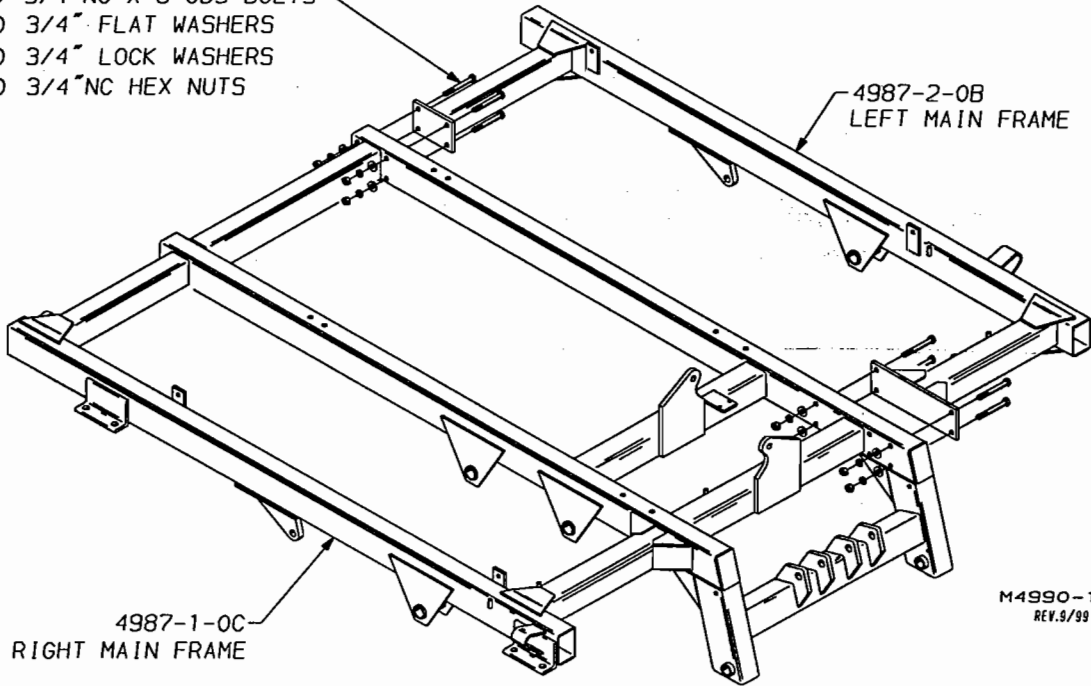

M4990-13
REV. 9/99

4. Place the CENTER FRAME ASSEMBLY on stands approximately 44" high in the center of the assembly area, facing a direction that will permit future hitching to a tractor.

NOTE: The stands will be required to support the assembly that will weigh approximately 3,450 lbs. before the tool will be self-supporting.

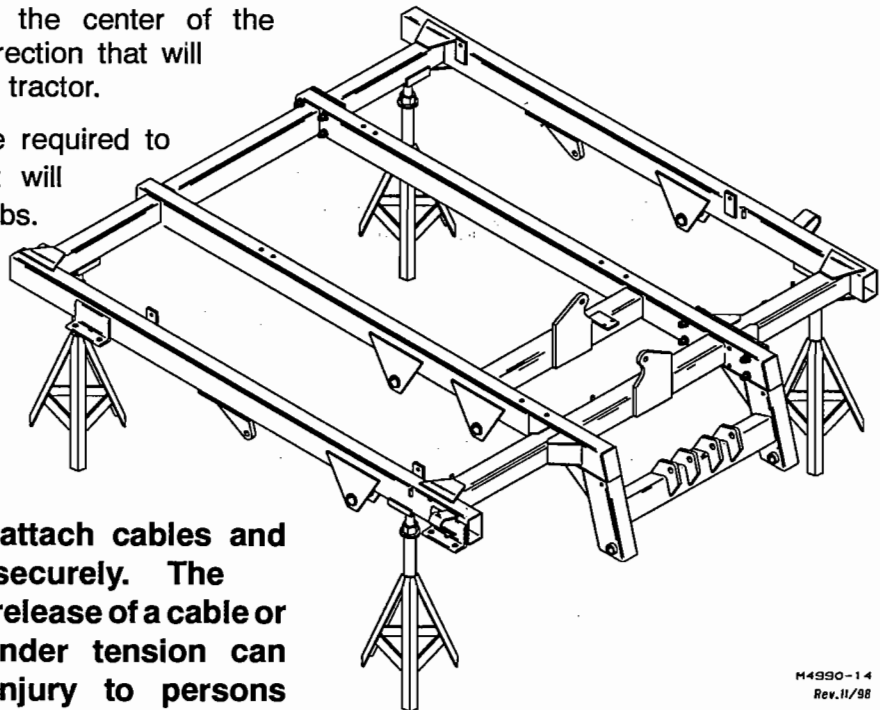

⚠ Caution: Always attach cables and chains securely. The sudden release of a cable or chain under tension can cause injury to persons standing nearby.

M4990-14
Rev. 11/98

II. TONGUE ASSEMBLY (Bolt Sack 4987-61-0)

1. Position the tongue in front of the frame with the spring and cylinder lugs on top.

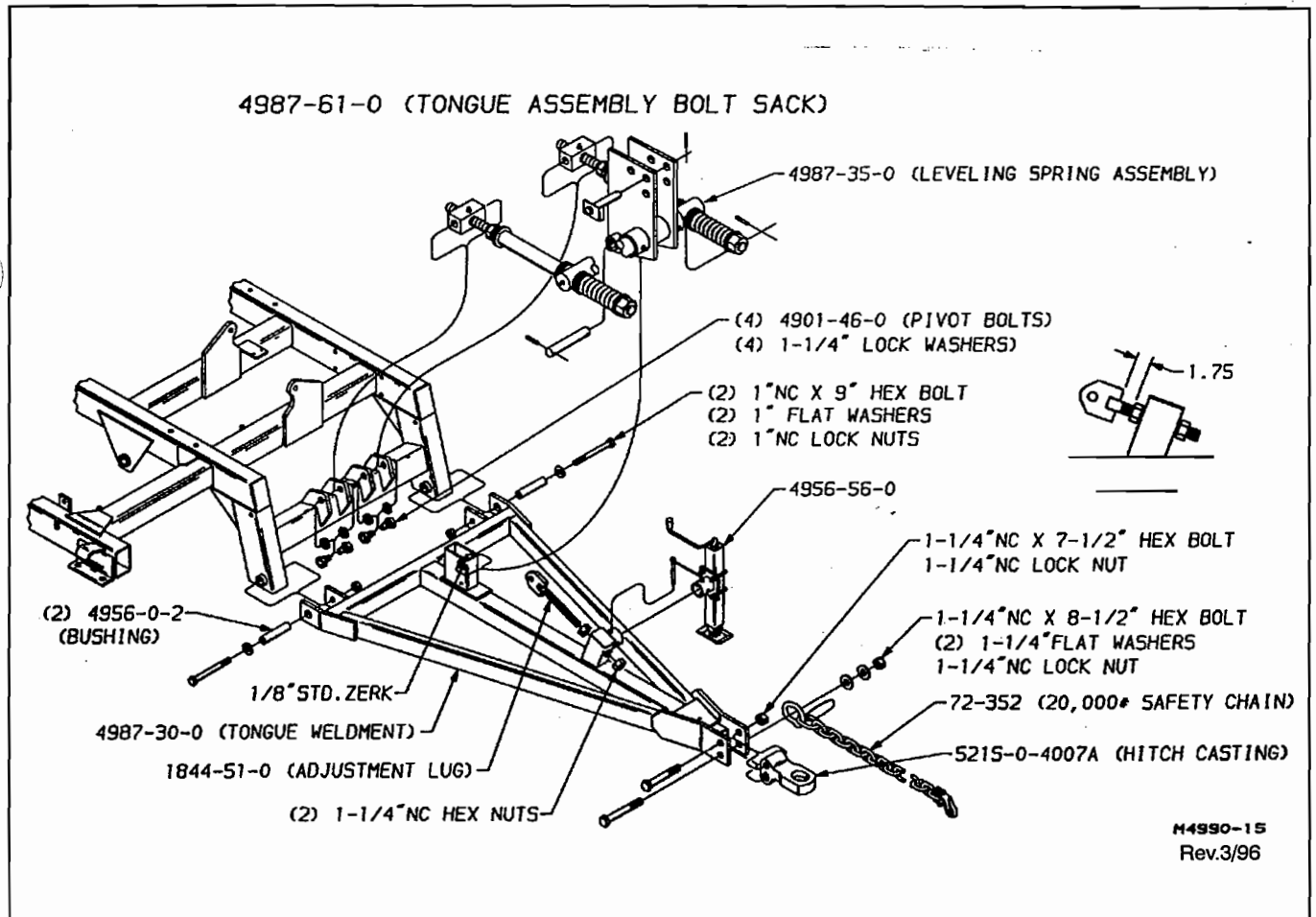
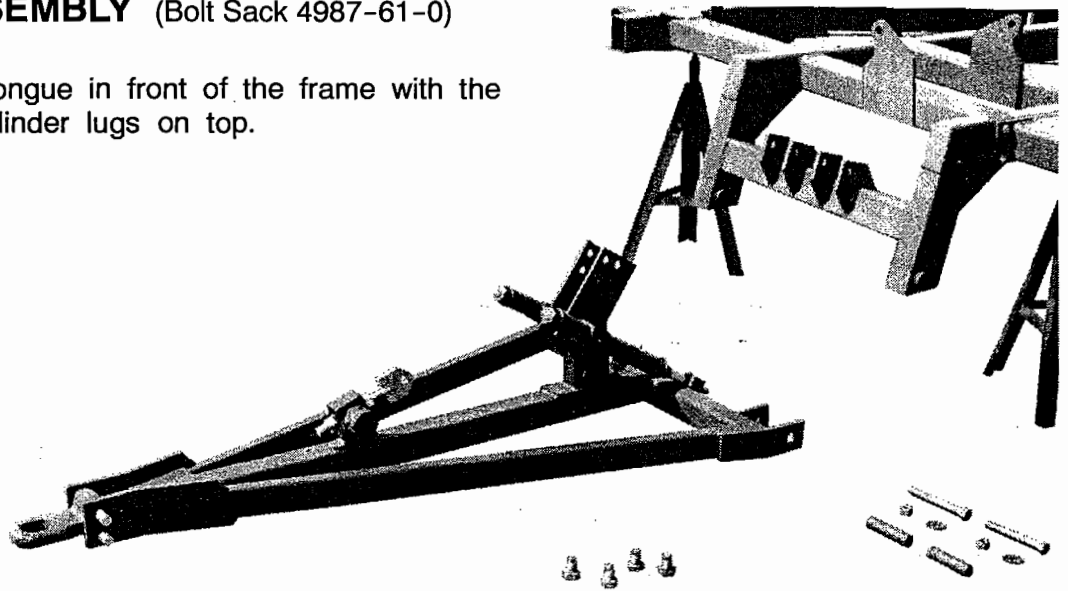

2. Fasten the TONGUE WELDMENT to the center frame.
3. Lift the tongue and assemble the TONGUE JACK.
4. Assemble the HITCH CASTING and SAFETY CHAIN.

5. Insert the ADJUSTMENT LUG into the jack mount tube and adjust it to 1-3/4" dimension as shown.
6. Screw a 1/8" ZERK into the leveling spring pivot tube.
7. Pin the LEVELING SPRING ASSEMBLY to the tongue as shown.
8. Attach the spring TRUNNIONS to the center frame lugs with special pivot bolts and lock washer. (Make sure the zerks are on the top side)
9. Assemble the 3-3/4" x 8" TONGUE CYLINDER to the lugs. Make sure the ports are on the bottom side of the cylinder.
10. Check assembly and adjust to dimensions shown in illustration below.

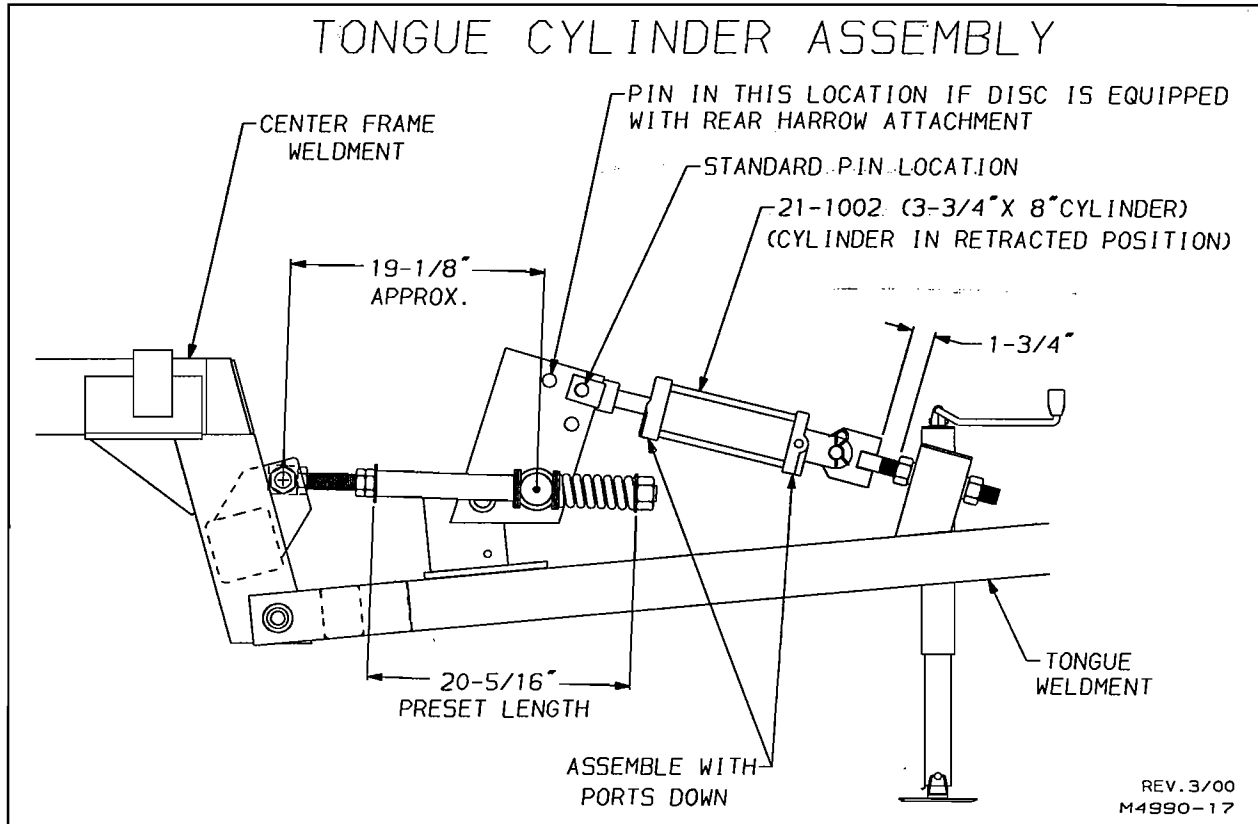

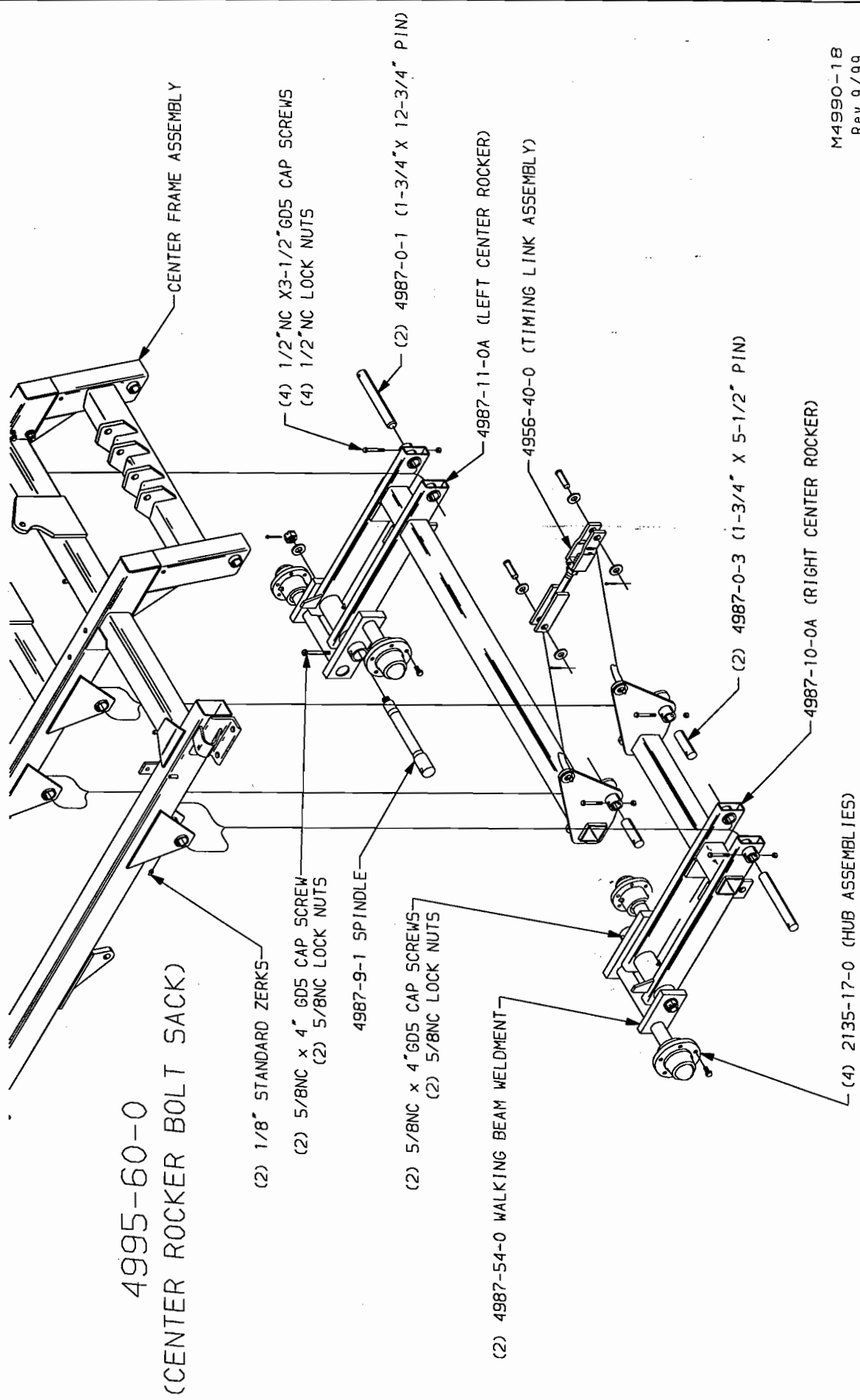

M4990-18
Rev.9/99

III. CENTER ROCKER ASSEMBLY (Bolt Sack 4987-60-0)

1. Pin the LEFT & RIGHT CENTER ROCKERS to the center frame pivots.
2. Connect the two rockers together with a 4956-40-0 TIMING LINK.
3. This series of tandems have been furnished with 15 x 10, 6 bolt wheels that require 10.00 x 15 tires. Remove the wheel bolts in each hub and attach the wheels and tires to the hubs through the countersunk bolt holes as shown in the drawing below.

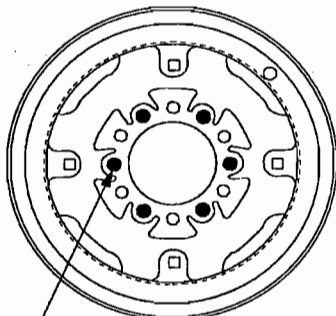
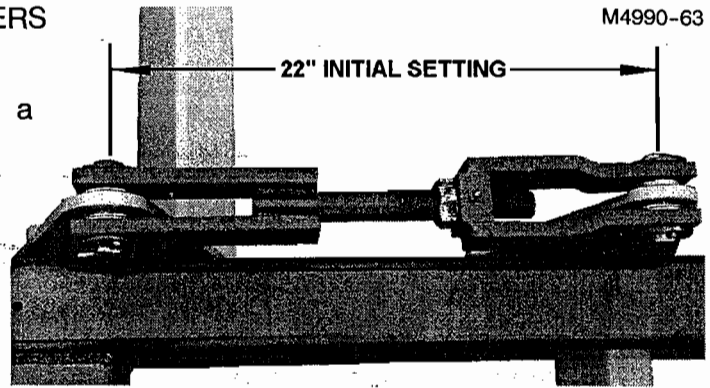

ALWAYS BOLT WHEEL TO HUB THROUGH COUNTERSUNK HOLES.

INFLATE 10.00 X 15 8-PLY TIRES TO 40 P.S.I.

IMPORTANT
TORQUE ALL WHEEL BOLTS FROM 90 TO 95 FT. LBS.

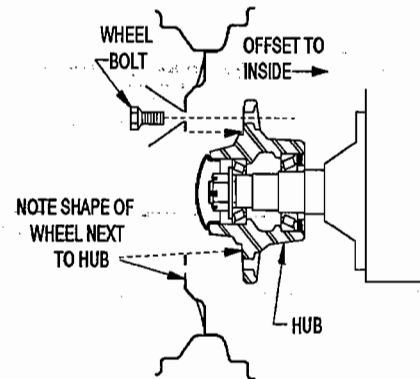

4. Assemble TWO 21-1004 (4-1/4" x 8" CYLINDERS) to the center frame lugs and center rocker lugs as shown in the following illustration with the ports on top.

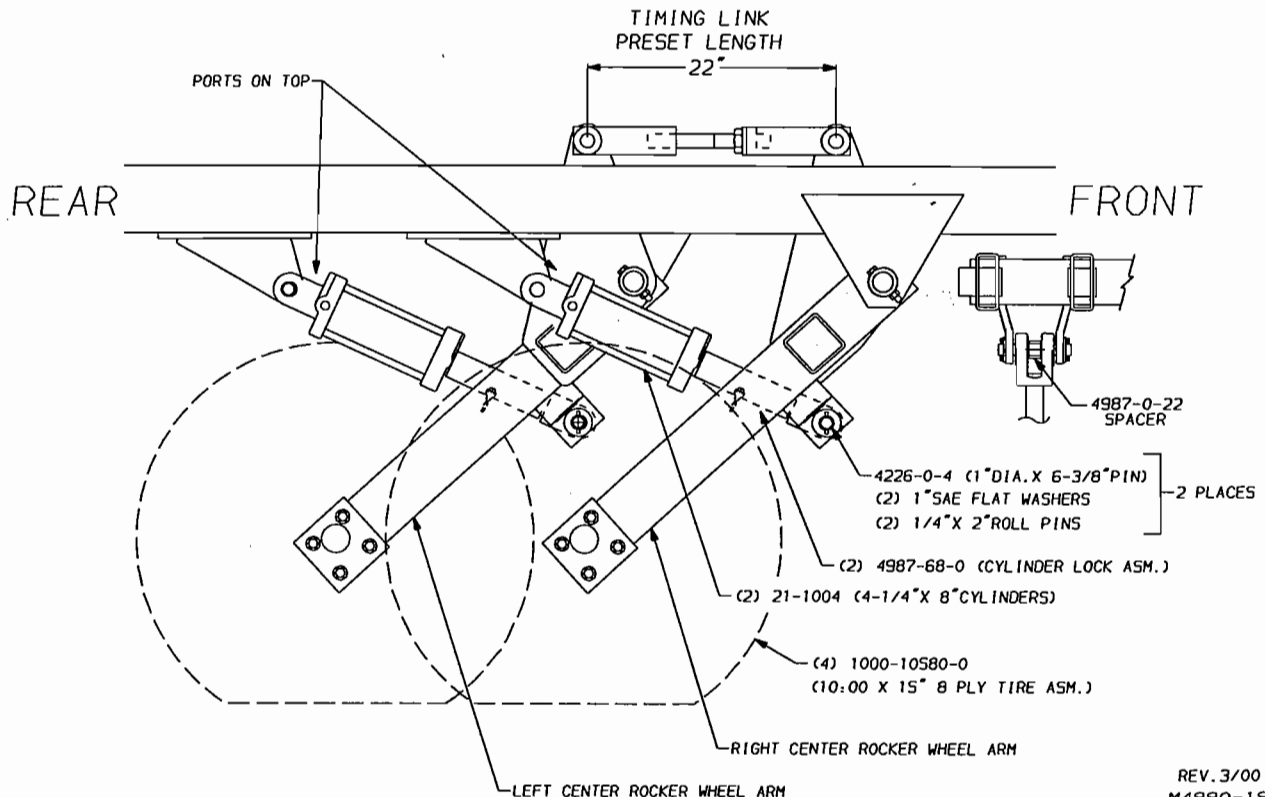

REV. 3/00
M4990-19

5. Assemble the cylinder locks onto the extended cylinder rods and retain them with P.T.O. Pins. Both cylinder locks must be used.

6. Lift rear end of frame assembly until the stands can be removed. The center assembly should now be free standing.

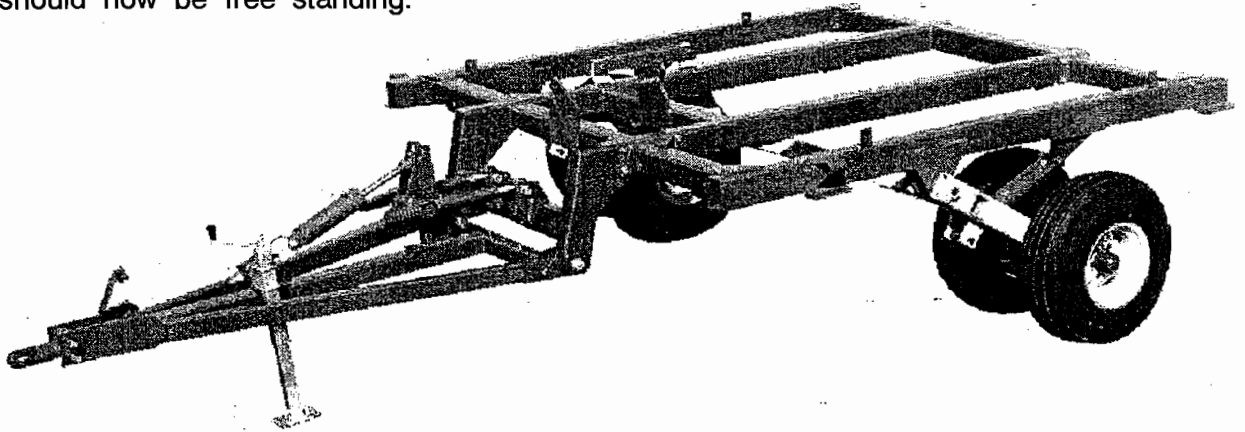

IV. CENTER GANG ATTACHMENT

(Bolt Sack #4987-62-0)

1. Refer to the Placement pages in the back of this manual to help select the correct location for each disc gang.
 - a) The center gangs have hinge tubes.
 - b) The rear gangs have mounting holes drilled through the gang beam.
 - c) The front center gangs have mounting sleeves welded on the side.
 - d) Left and right can be identified by hinge tube alignment.
2. Roll each disc gang assembly under the frame at their specific locations.

⚠ Danger: Due to their sharpness and weight, serious injury can be inflicted by blades and gangs if not handled safely. Watch for unsafe conditions. Keep your co-workers safety in mind. Should personal injury occur, have medical treatment administered immediately.

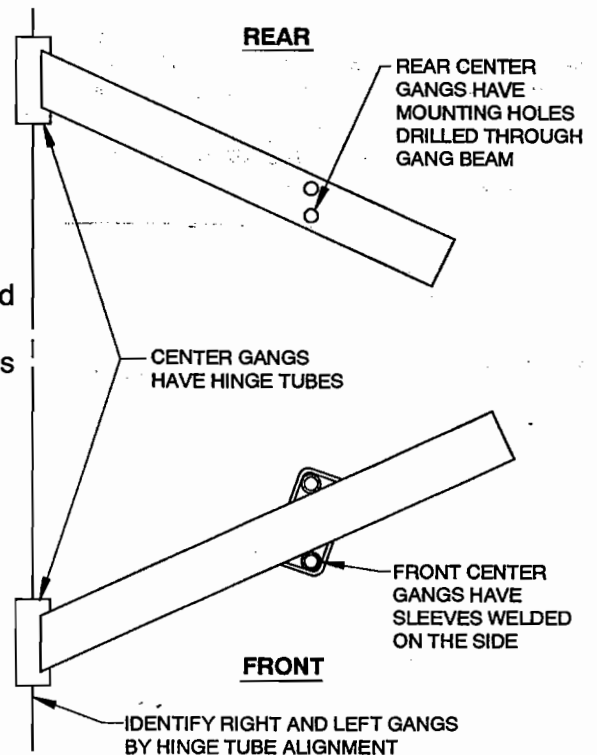

M4990-35

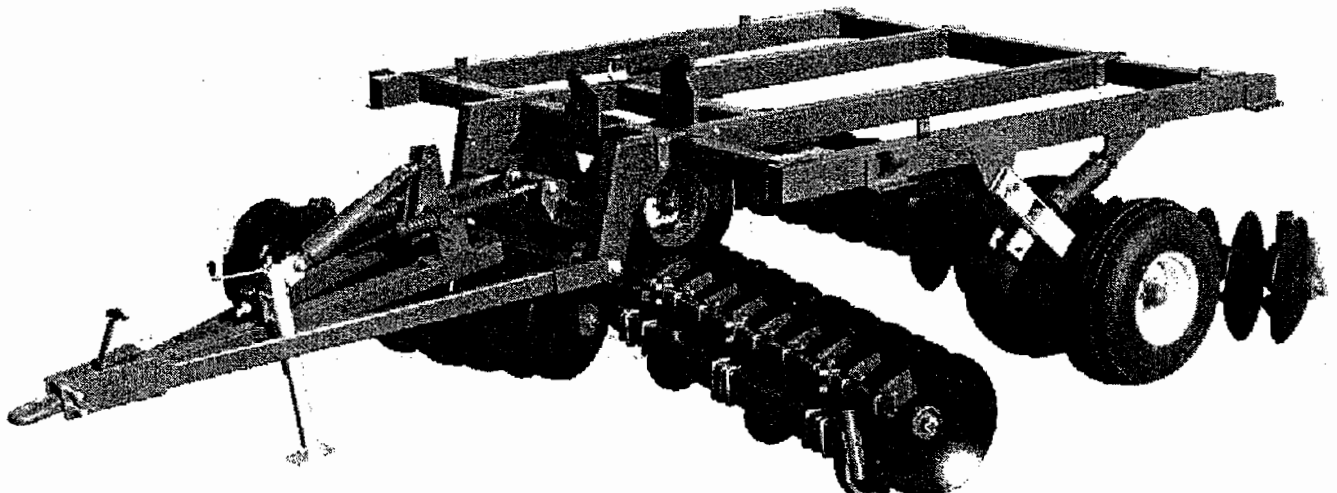

M4990-37

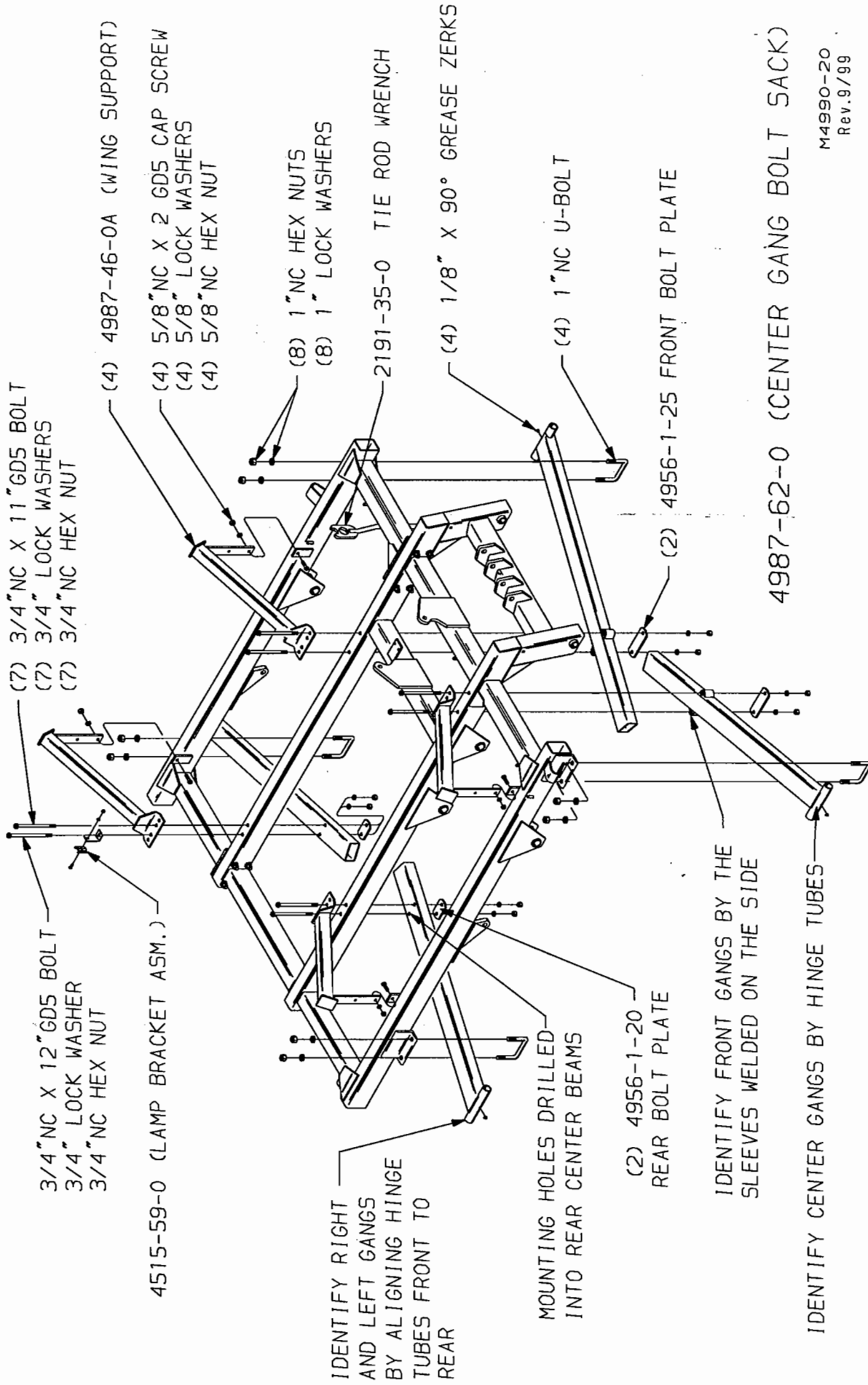

M4990-20
Rev. 9/99

3. Bolt the FOUR (4987-46-0A) WING SUPPORTS to the center frame outer beams with 5/8NC x 2" GRD. 5 Cap Screws, Lock Washers, and Hex Nuts.
4.
 - a) Starting with the front disc gang, loop a length of chain around the center spacer spool and gang beam.
 - b) Raise the assembly until it is against the bottom of the center frame.
 - c) Position a BOLT PLATE under the inside end of the gang beam and fasten the bolt plate, gang beam and wing support to the center frame with 3/4NC x 11" GRD. 5 Bolts, Lock Washers, and Hex Nuts.
 - d) Attach the outer end of the center gangs to the frame angles with 1" DIA. U-Bolts, Lock Washers and Hex Nuts.
 - e) Do not tighten center gang mounting U-Bolts until the wing frames have been assembled.
 - f) Screw in 1/8NPT x 90° Zerks into each hinge tube.

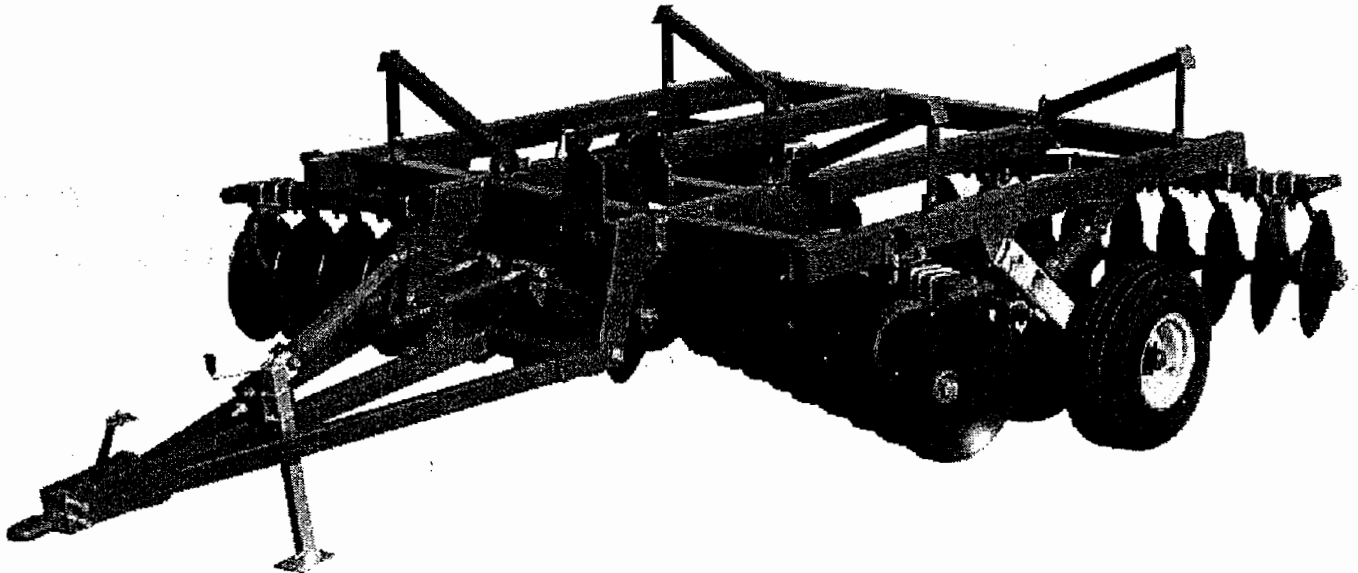

COMPLETED CENTER SECTION

4988-63-0 (WING & GANG BOLT SACK)

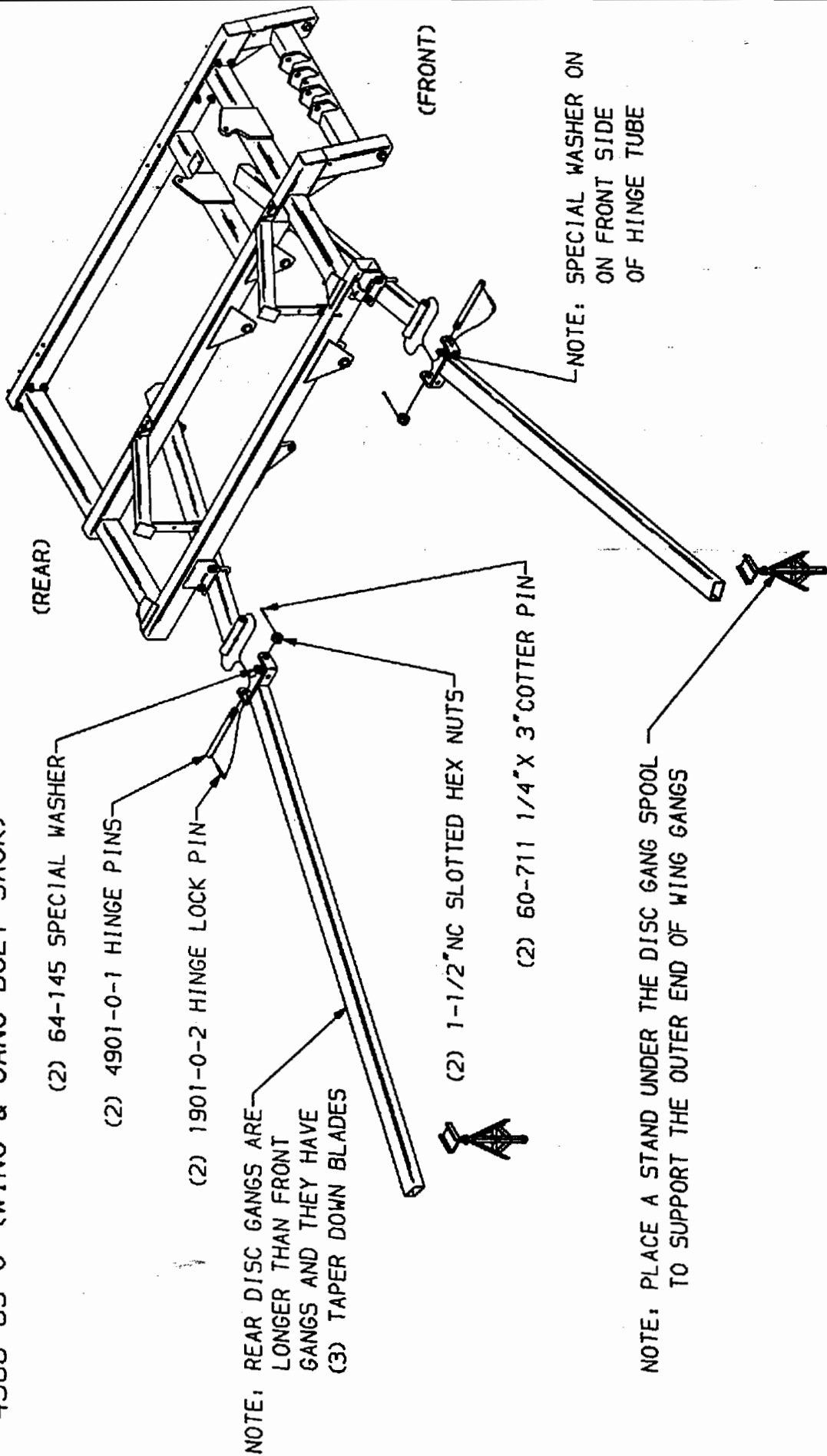

V. WING FRAME ASSEMBLY

(Bolt Sack #4988-63-0)

FRONT GANG

M4990-39

1. Attach the wing gang assemblies to the center frame hinge tubes.

The rear wing gang assemblies are longer than the front gang beams.

BACK

NOTE: Make sure that the **SPECIAL WASHER** is on the **FRONT** side of the hinge tube.

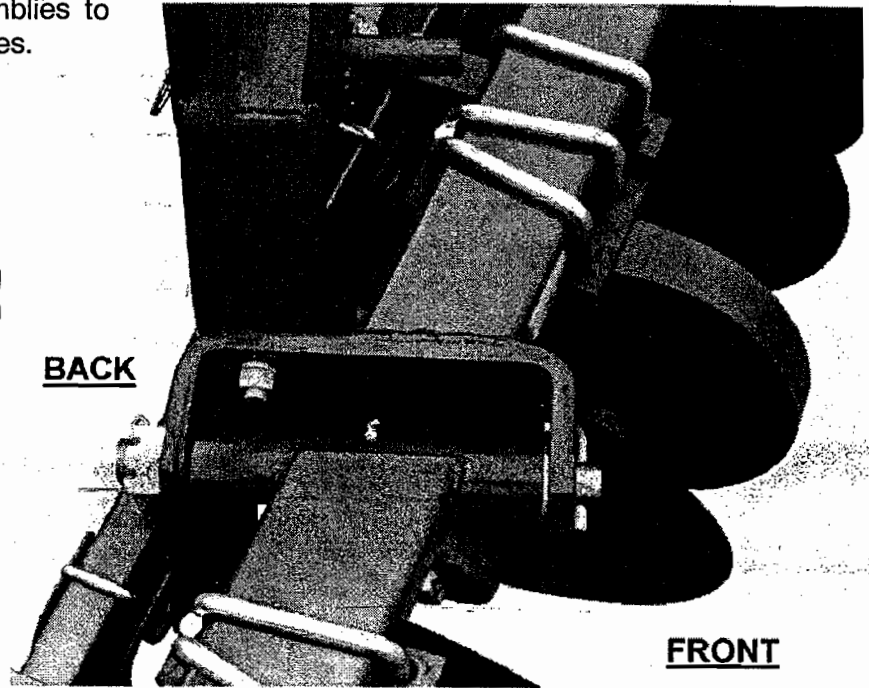

FRONT

2. Support the outer end of the wing gangs with frame stands.

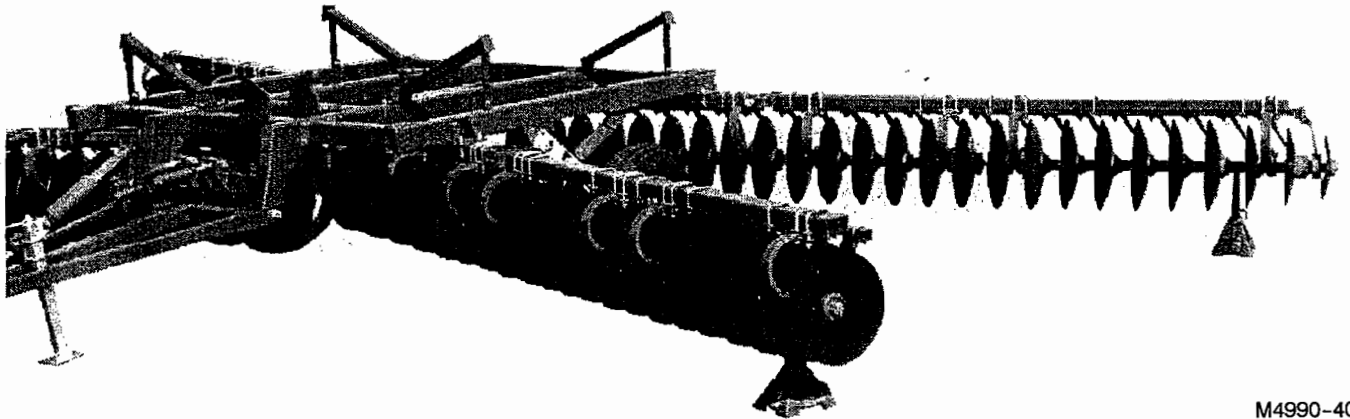

M4990-40

4988-63-0 (WING & GANG BOLT SACK)

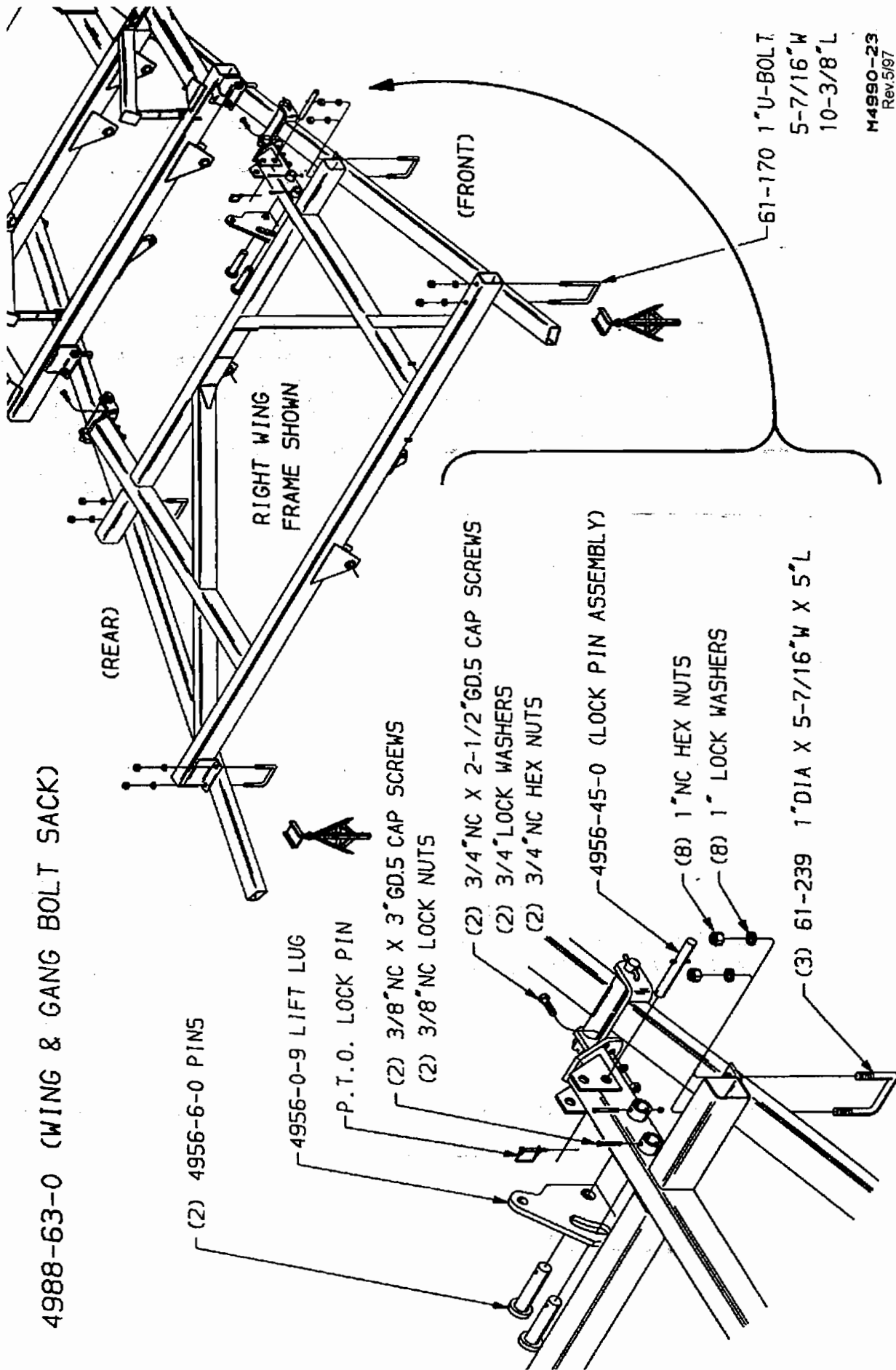

3. Place the wing frames on top of the gang beams. The wing lock plates and wing lift lugs should be on top and toward the front.
4. Bolt the wing to the hinge clevis with 3/4NC x 2-1/2" Cap Screws, Lock Washers and Hex Nuts.
5. Fasten the wing to the rear gang and inside front gang with 1" DIA. U-Bolts with 5" legs.
6. Fasten the front outer end with a 1" DIA. U-Bolt with 10-3/8" legs.
7. Assemble the wing lift lugs (4956-0-9) to the wing frame with (2) PINS (4956-6-0). Retain the pins with 3/8NC x 3" Cap Screws, and 3/8NC Lock Nuts.
8. Assemble WING LOCK PIN ASSEMBLY (4956-45-0) the storage hole as shown.

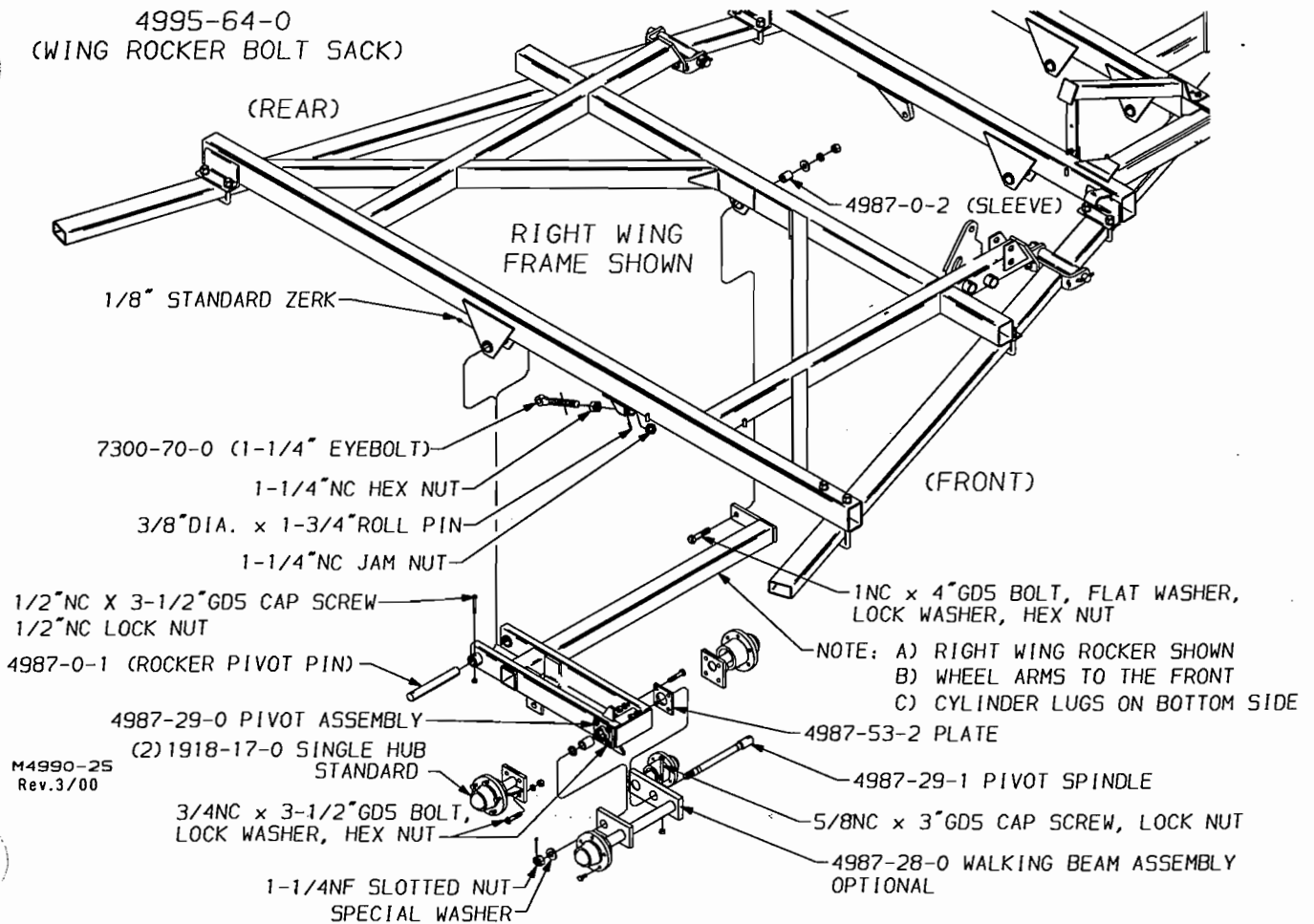
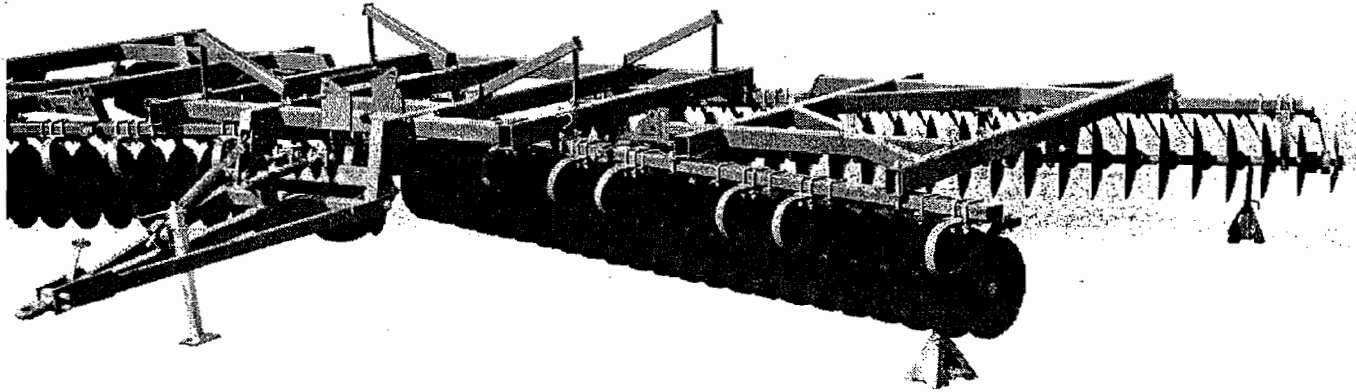

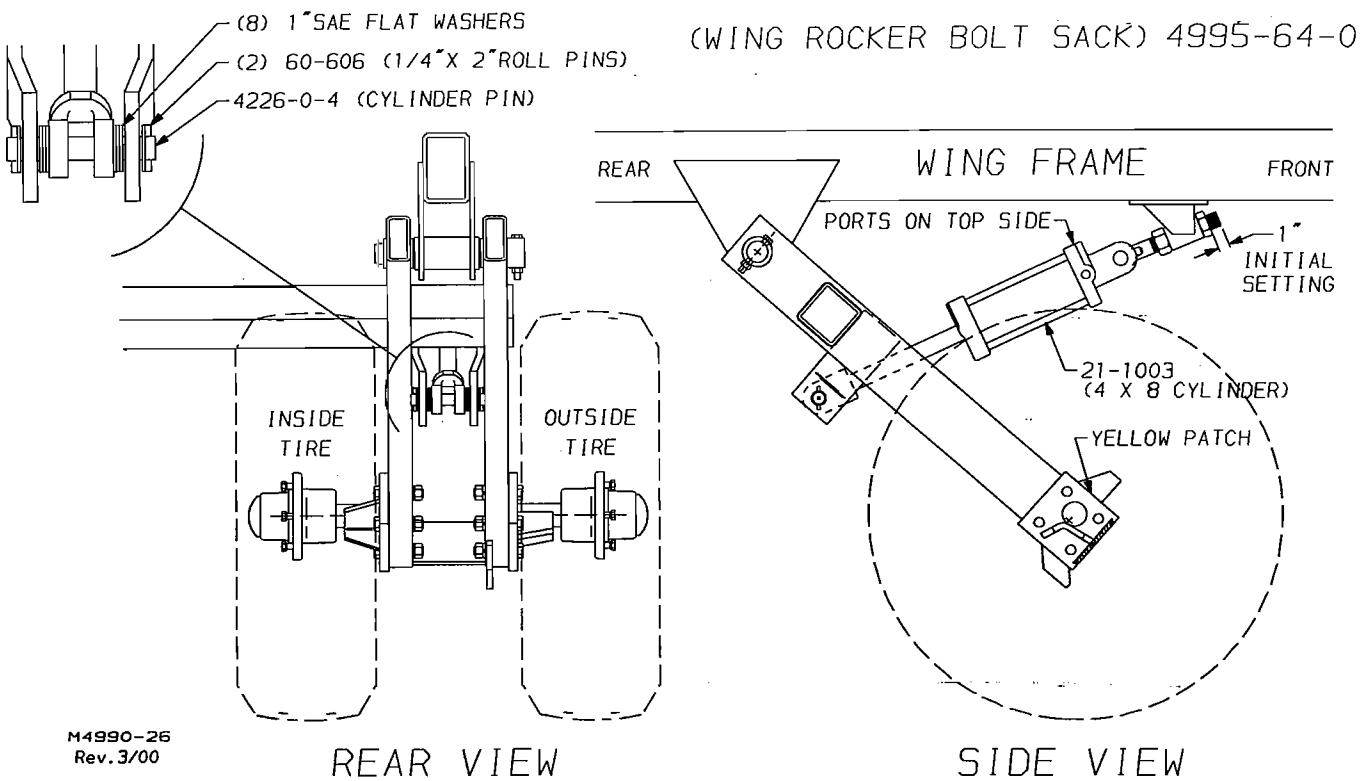

VI. WING ROCKER ASSEMBLY (Bolt Sack #4995-64-0)

1. Lay the wing rockers underneath the wing frames. The wheel arms should be towards the front and the cylinder lugs should be down.
2. Pin the outer end of the wing frame with a (4987-0-1) pivot pin (1-3/4" Dia. x 12-1/2").
3. Fasten the inside end of the wing rocker to the frame with a 1NC x 4" GD. 5 Bolt, 4987-0-2 Sleeve, 1" STD. Flat Washer, 1" STD. Lock Washer, and 1NC Hex Nut.
4. Fasten the wing rocker adjustment Eyebolt to the wing frame with a 1-1/4NC Hex JAM Nut on the **FRONT** side. Insert a 3/8" DIA. x 1-3/4" Roll Pin through tube slot and wing rocker adjustment eyebolt to keep eyebolt from rotating. For initial setting, there should be 1" of thread showing.
5. Assemble a 21-1003 (4" x 8" Series Cylinder) to each wing rocker with a (4226-0-4) 1" DIA. x 6-3/8" Pin in the rod end. There are (8) 1" SAE Flat Washers required, (3) on each side of the rod end clevis and (1) on the outside of each rocker lug.
6. Standard Dual Wheels -- Attach the dual wheel hub assembly to the wheel arms using 3/4NC x 3-1/2" GD5 Bolts, Lock Washers and Hex Nuts. Be sure that the yellow patch on the spindle plate is positioned on the top. Torque wheel bolts to 90-95 Ft. Lbs.

Optional Walking Beams -- Remove the zerk from the Walking Beam Pivot Assembly (4987-29-0), see illustration on page A15, and slide it into the hole in the wing wheel arms. Position the zerk hole so that it points toward the long rocker cross beam. Slide the Retainer Plate (4987-53-2) over the pivot and secure both ends with 3/4NC x 3-1/2" GD5 Bolts, Lock Washers and Hex Nuts. Remove the Center Spindle (4987-29-1) from the Pivot Assembly and position the Walking Beam weldment (4987-28-0) with the cross spindle to the bottom of the wheel arms between the rotation stops and reinsert the Center Spindle. Torque the Center Spindle Nut to 25-30 Ft. Lbs. Reinstall zerk and fill pivot tube with grease. Torque wheel bolts from 90 to 95 Ft. Lbs.

IMPORTANT: CHECK THE HUBS FOR EXCESSIVE END PLAY. IF NECESSARY, ADJUST WHEEL HUB AT THIS TIME IN THE ASSEMBLY.

DO NOT ALLOW DIRT AND DUST TO ENTER THE HUBS. DIRT IN THE HUBS MAY RESULT IN BEARING FAILURE DURING OPERATION.

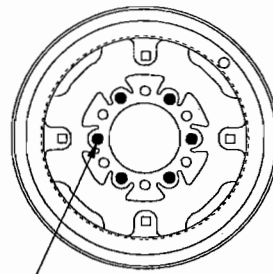

ALWAYS BOLT WHEEL TO HUB THROUGH COUNTERSUNK HOLES.

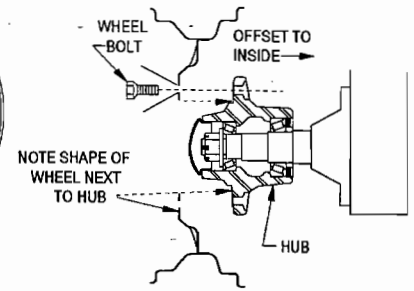

NOTE SHAPE OF WHEEL NEXT TO HUB

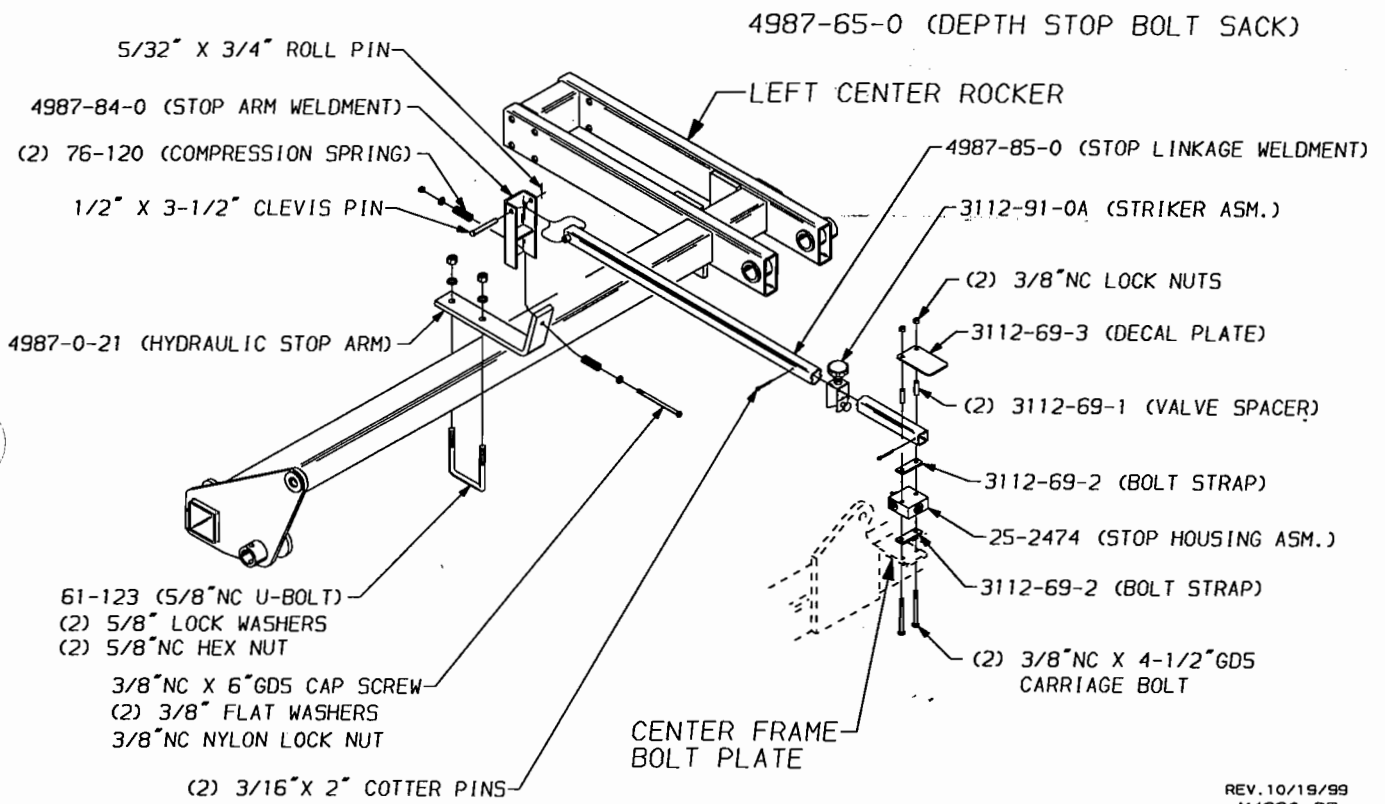

REV. 10/19/99
 M4990-27

VII. DEPTH STOP LINKAGE ASSEMBLY (Bolt Sack #4987-65-0)

1. Locate the center frame stop valve bolt plate.
2. Assemble the linkage as shown on page A17.
3. Tighten the 3/8NC x 6" Bolt on the STOP ARM WELDMENT until the spring length is 1-13/16" as shown below.

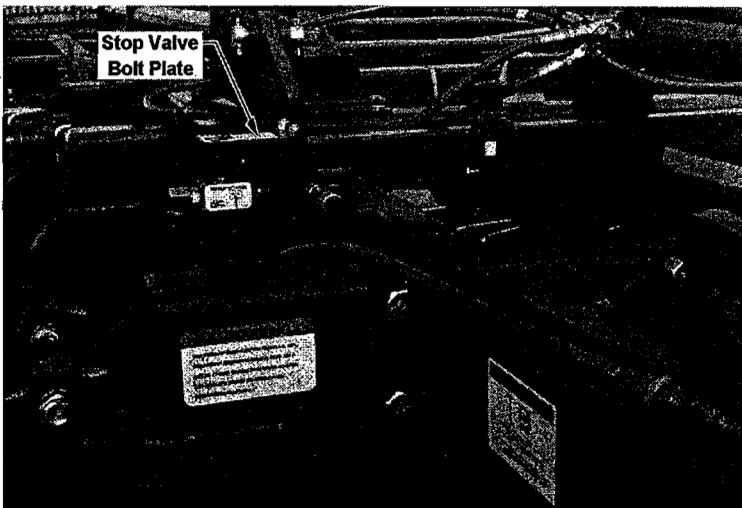
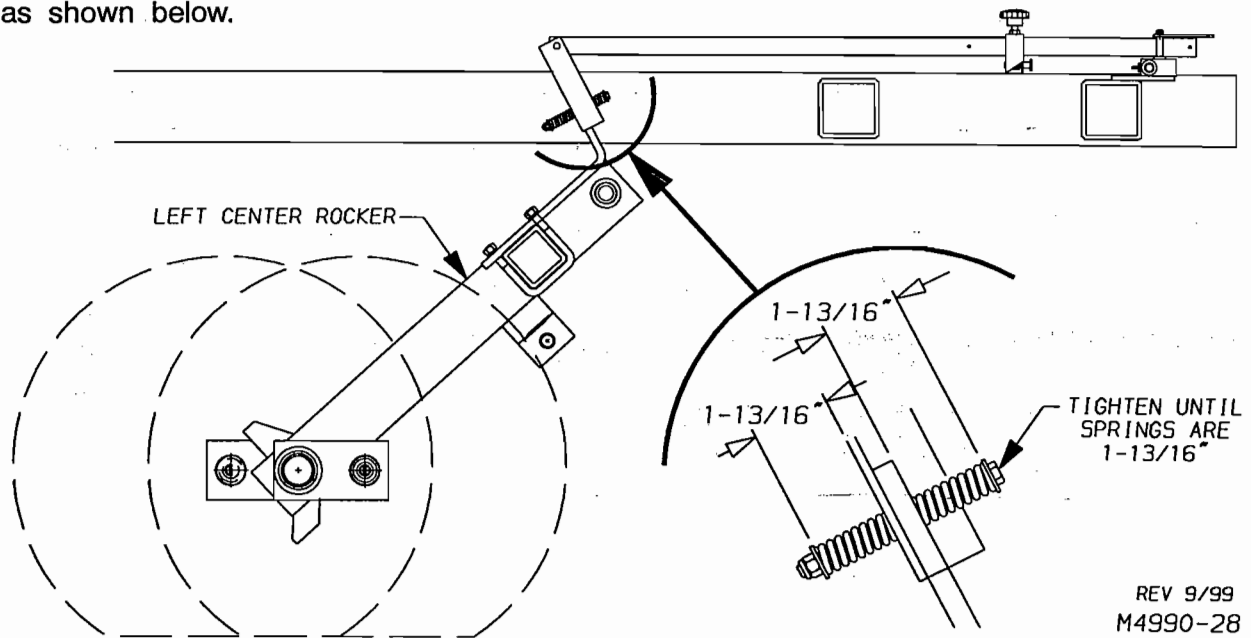

M4990-64

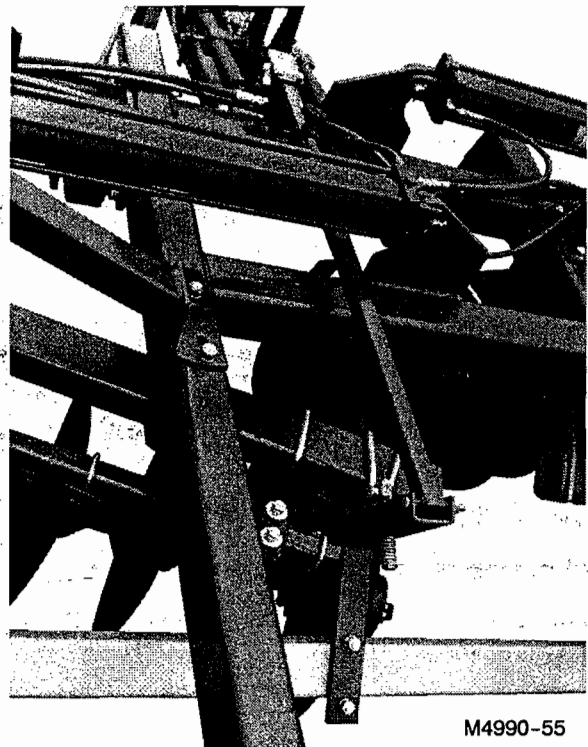

M4990-55

VIII. HYDRAULICS ASSEMBLY

⚠ Caution: Use only hydraulic hose that meets or exceeds 3,000 P.S.I. working pressure.

IMPORTANT: DO NOT PIN THE ROD END OF THE WING FOLD CYLINDERS UNTIL ALL HYDRAULIC ASSEMBLY IS COMPLETE AND THE SYSTEM HAS BEEN PURGED OF AIR AND FILLED WITH OIL.

WING LIFT CYLINDER ASSEMBLY

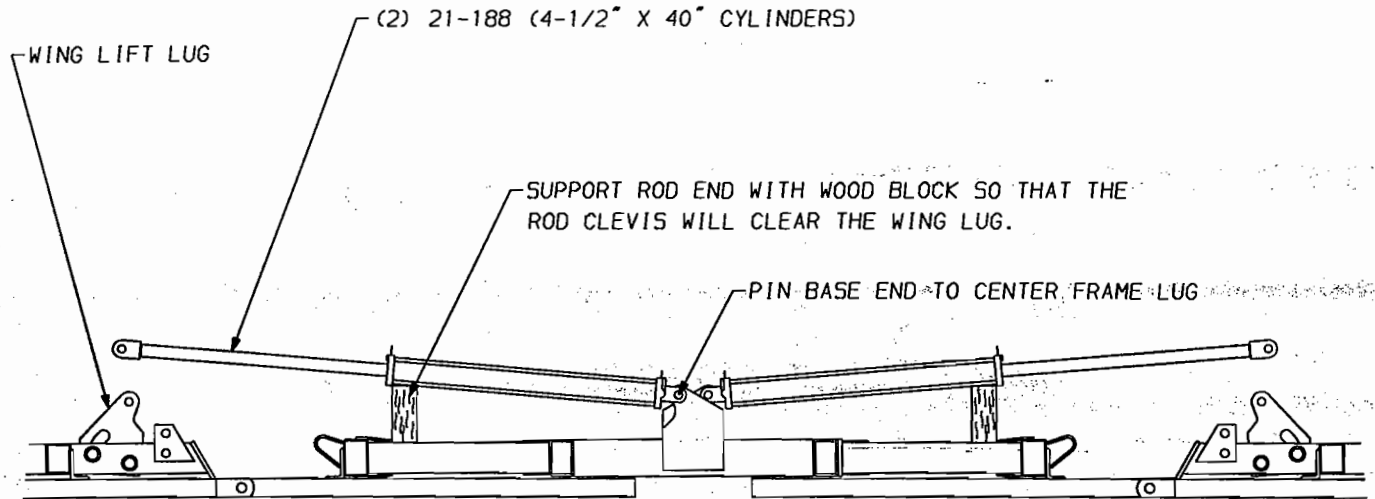

M4990-30
REV. 9/99

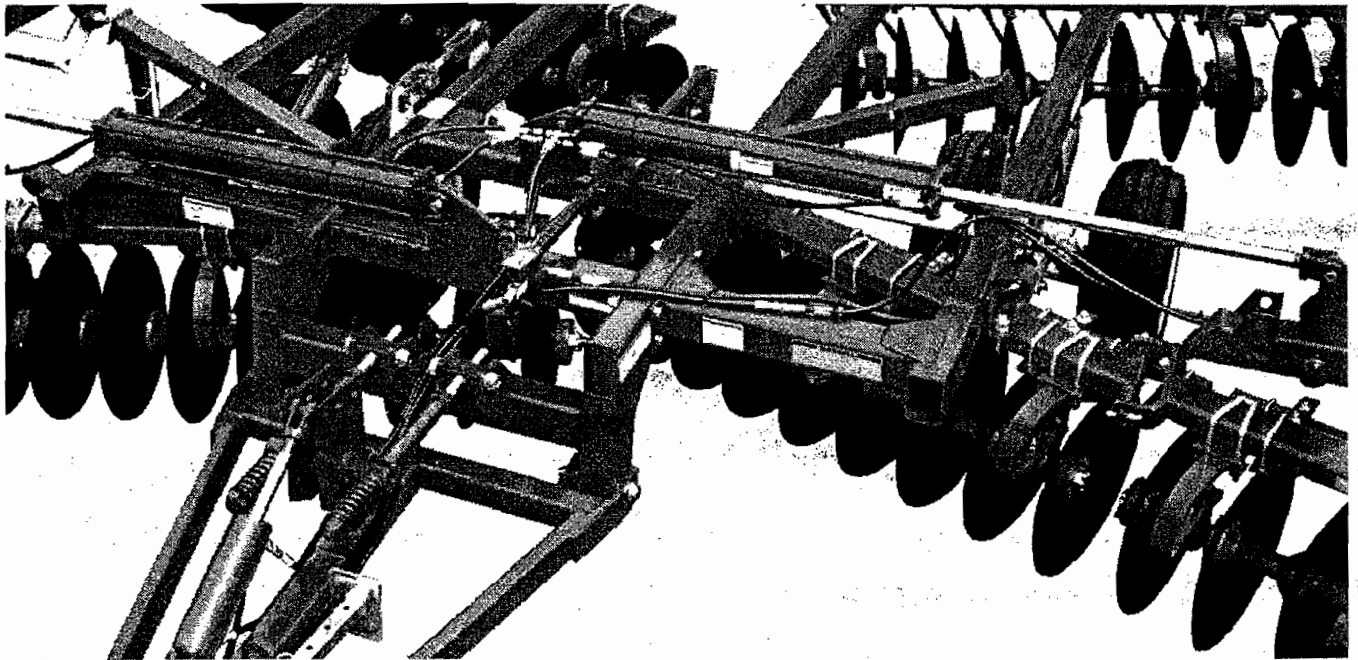

M4990-92

1. Pin the base end of the (2) 21-188 4-1/2" x 40" Wing Lift Cylinders to the center frame lugs, and block up the rod ends to clear lugs. (See figure M4990-28 on previous page)
2. PLUMBING --

NOTE: No tape or sealant is necessary on O-Ring / 37° Flare Fittings.

Refer to the parts section Hydraulic Hose Kit pages P29 through P33 and the following photographs for the correct assembly of hoses, fittings, and hose clamps.

IMPORTANT: A 90° RESTRICTOR SHOULD BE ASSEMBLED INTO BOTH ROD END AND BASE END PORTS OF EACH WING LIFT CYLINDERS. THE RESTRICTOR CAN BE IDENTIFIED BY A TAG ATTACHED TO IT. PROPER LOCATION OF THESE FITTINGS IS IMPORTANT TO PREVENT THE IMPLEMENT WINGS FROM FREE-FALLING IF A HYDRAULIC FAILURE SHOULD OCCUR.

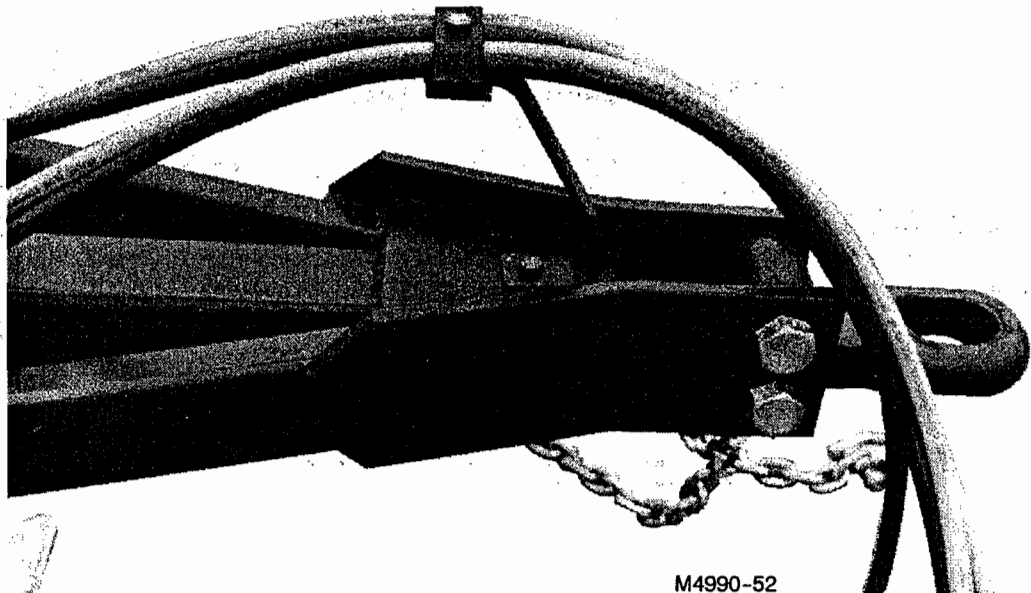
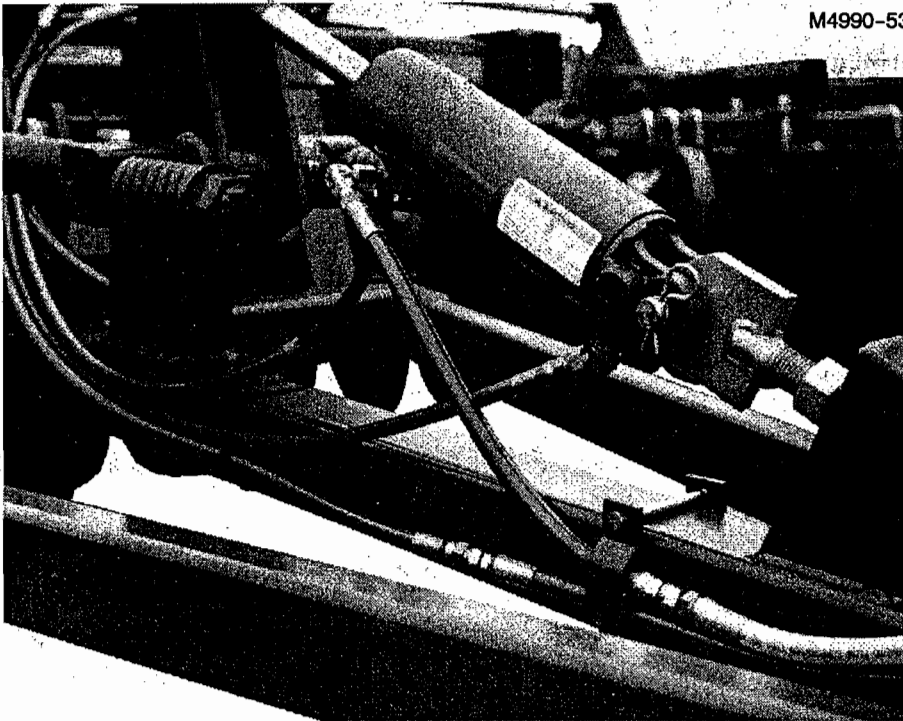

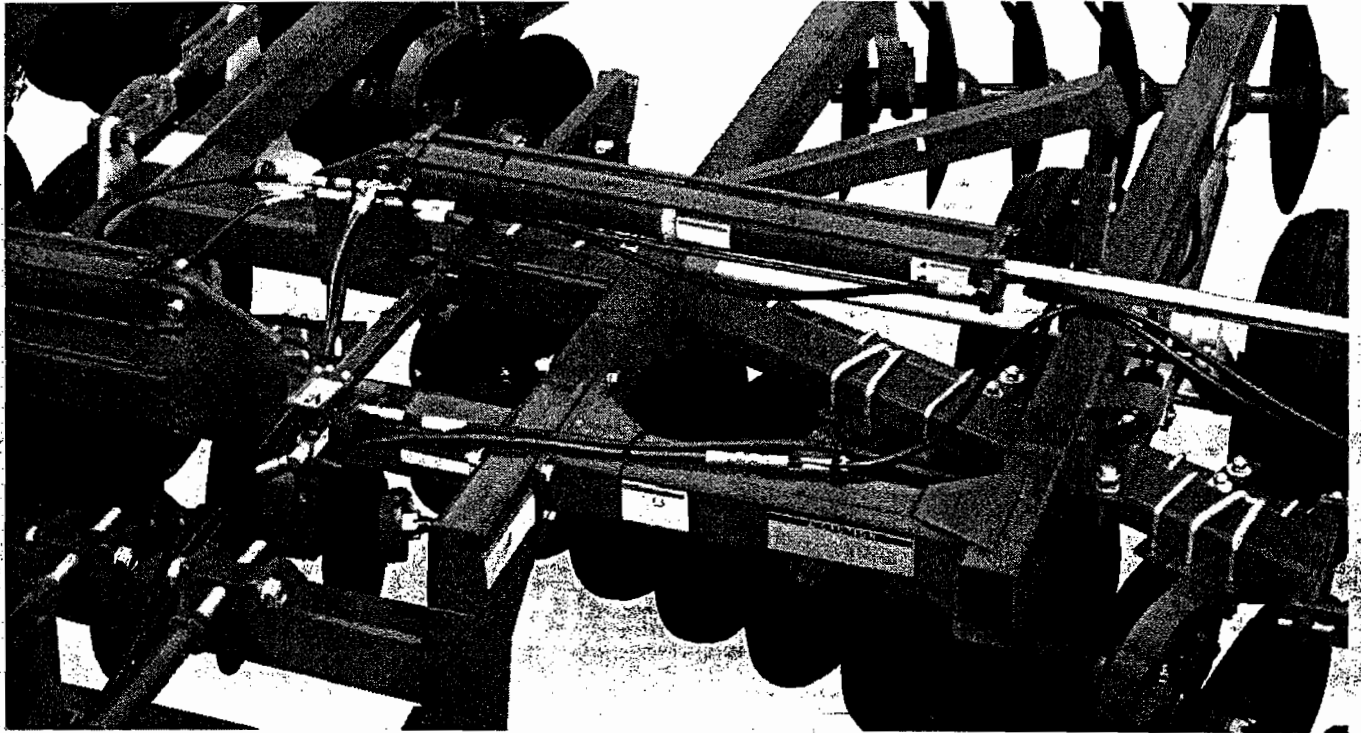

M4990-91

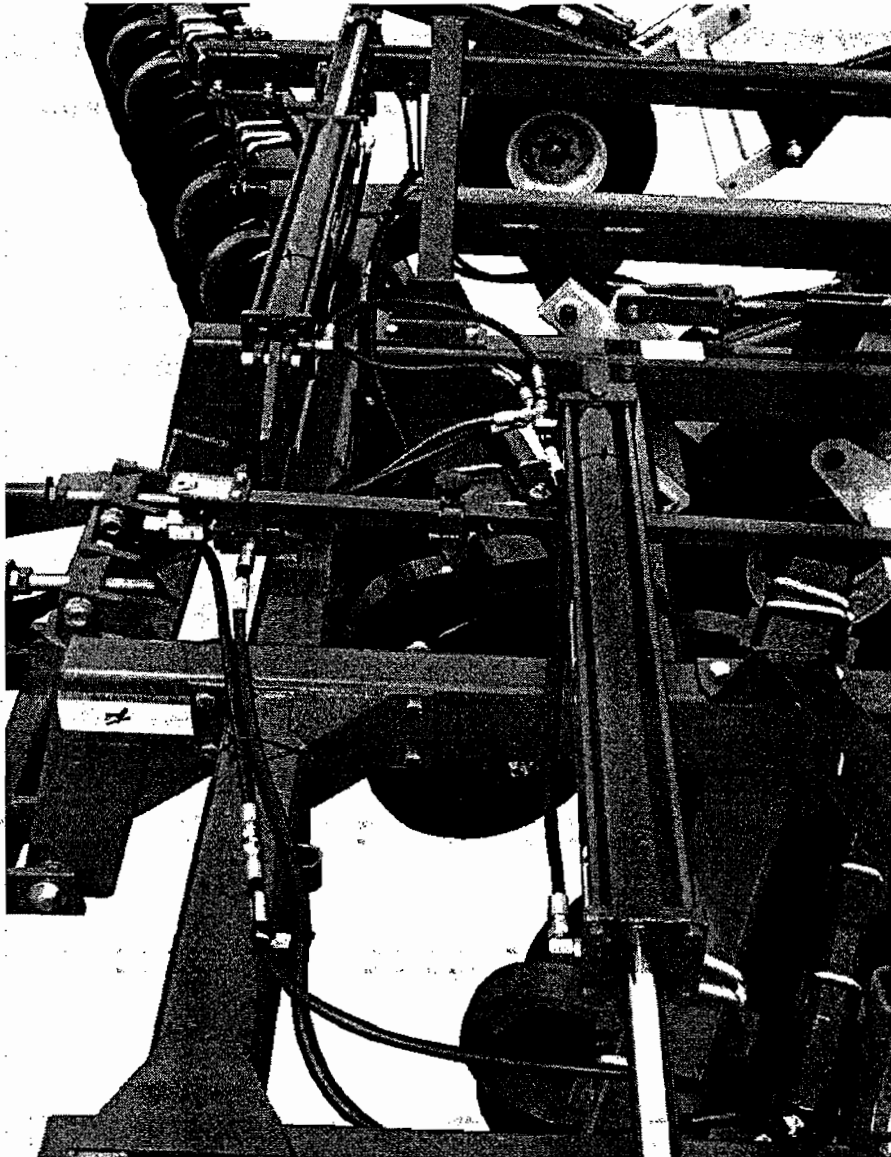

M4990-95

**LEFT FRONT CENTER
FRAME SHOWN**

M4990-48

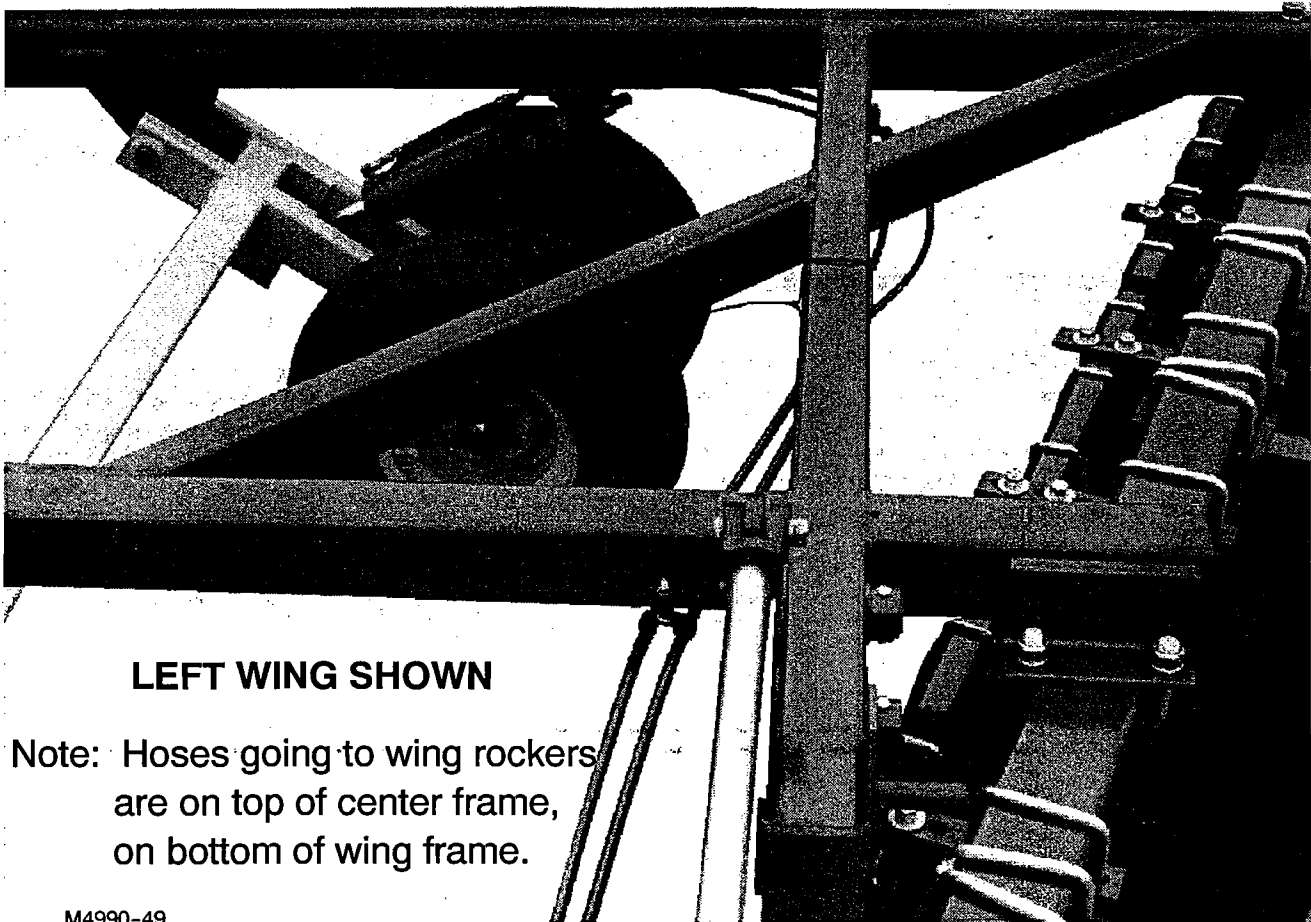

LEFT WING SHOWN

Note: Hoses going to wing rockers
are on top of center frame,
on bottom of wing frame.

M4990-49

3. CHARGING THE CYLINDERS --

- a) After all hose and fittings are assembled, check the blocks under the wing cylinders. Make sure that they are raised high enough to clear any attaching lugs.
- b) Attach hydraulic hoses to the tractor. Check the tractor hydraulic reservoir and make sure it is full of the tractor manufacturer's recommended oil.
- c) If you are sure all connections are tight and leakproof, begin filling the system by extending and retracting the cylinders.
- d) The rocker shaft cylinders have rephasing grooves that will allow the oil to pass by the piston when the disc is fully raised. Open the road lock valve and raise the unit. Hold the tractor lever in the raised position to fill each rocker shaft cylinder. When the cylinders are fully extended, remove the cylinder locks on the master cylinders and place them in the storage position on the vertical leg of the wing support weldments.

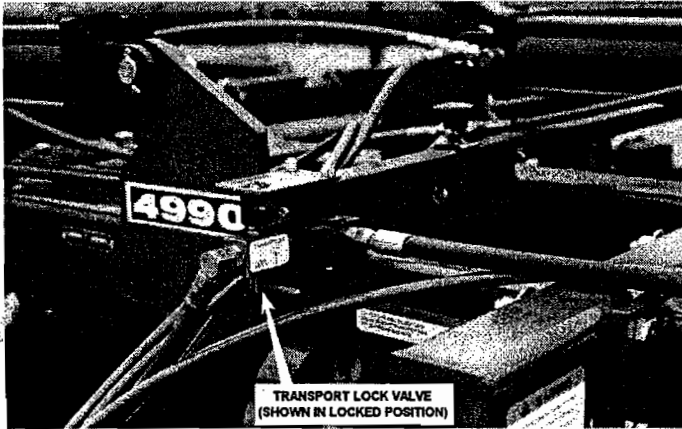

M4990-47

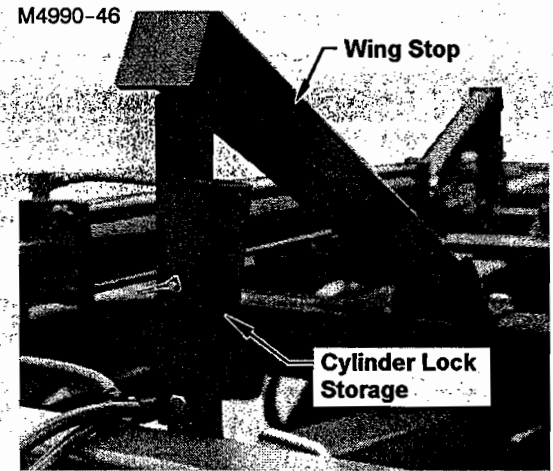

M4990-46

- e) Cycle the hydraulic cylinders until all air is purged from the system. When cycling the rocker shaft cylinders, hold the lever for 30 to 45 seconds in the fully raised position to rephase the cylinders.
- f) Continue the cycles until the cylinders respond with immediate solid actuation.

⚠ Warning: Escaping fluid under pressure can penetrate the skin causing serious injury. Avoid the hazard by relieving pressure before disconnecting hydraulic lines. Tighten all connections before applying pressure.

Search for leaks with a piece of cardboard. Protect hands and body from high pressure fluids.

If an accident occurs, see a doctor immediately. Any fluid injected into the skin must be surgically removed within a few hours or gangrene may result.



- g) After the wing cylinders are full, extend them to maximum length and remove the wood blocks.

IMPORTANT: AFTER PURGING THE HYDRAULIC SYSTEM OF AIR, PIN THE ROD ENDS OF THE 4-1/2" X 40" WING LIFT CYLINDERS WITH #21-859 CLEVIS PINS. SECURE THE CLEVIS PINS WITH (2) #21-860 ROLL PINS.

IX. WING LOCKS

1. 1-1/4" x 9-3/8" Lock Pins are used to lock the wings for transport.
2. The lock pins are held in place with P.T.O. Pins.
3. There is an additional hole in the wing lock bracket that is for pin storage when not in use.

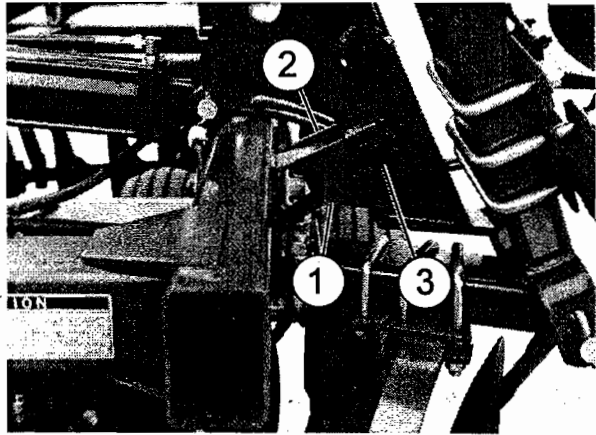

X. DECAL ATTACHMENT & SMV EMBLEM

It is very important that all decals be placed on the harrow as shown in the parts drawing on page P39 of this manual. These decals, reflectors, safety, and operating messages are just as important as the parts that have been assembled. NOTE: Wipe frame members clean before applying decals for better adhesion. If decals or reflectors should become faded or damaged be sure to replace them. Insert the SMV emblem and mounting spade into the SMV bracket bolted to the left rear wing support weldment.

XI. LIGHT KIT

Always comply with state and local laws pertaining to lighting. Install the Light Kit as shown pages P40 and A25 in this manual.

FINAL CHECK

1. Check the hydraulic system for leaks.
2. Lubricate all grease points.
3. Fully extend depth control cylinders. Close transport lock valve.
4. Lower tongue jack.
5. Check tire pressure and wheel bolt torque.
6. Perform final inspection. See Dealer Predelivery Check Sheet (follows Warranty page at the front of this manual.)

⚠ Caution: Explosive separation of a tire and rim parts can cause serious injury or death.

Always maintain the correct tire pressure. Do not inflate the tires above the recommended pressure. Inspect tires and wheels daily. Do not operate with low pressure, cuts, bubbles, damaged rims or missing lug bolts and nuts.

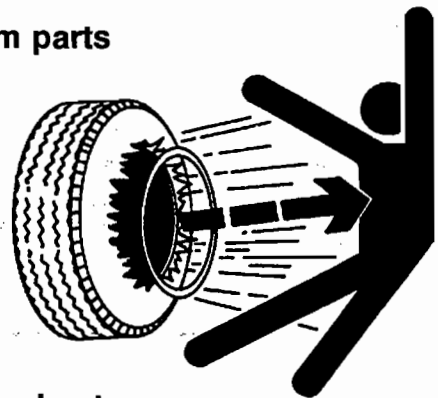

4995
LEFT REAR HINGE

4995
RIGHT REAR HINGE

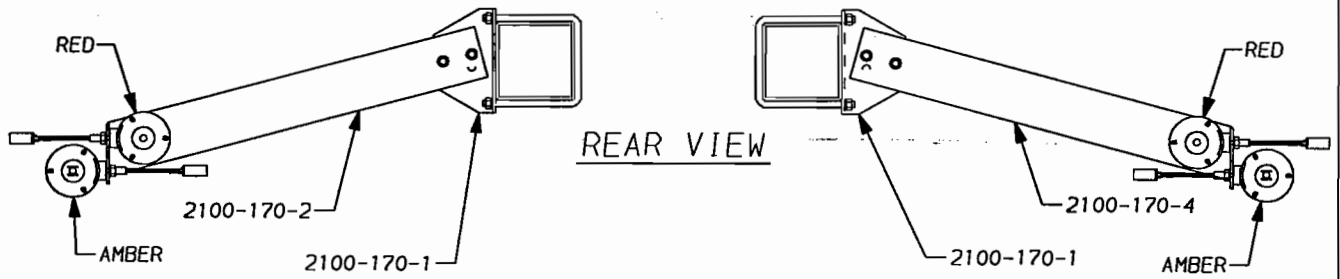
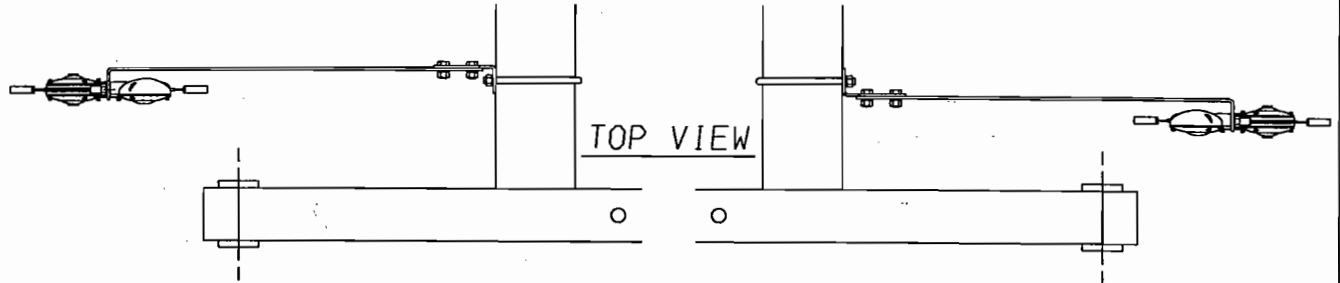

M4990-109
REV. 9/99

MODELS 4995-28N AND 4995-28NR 22" BLADES 8" SPACING

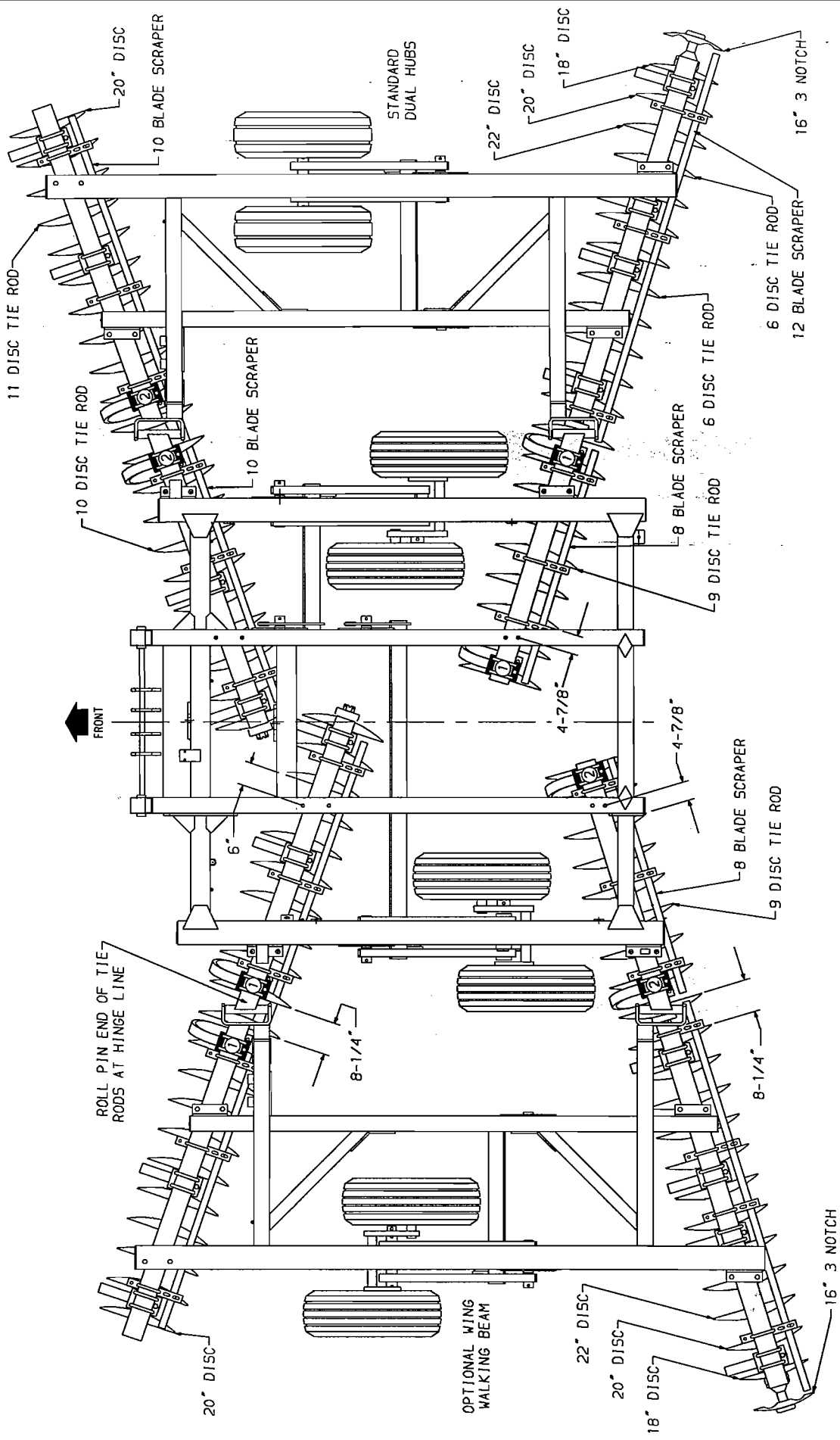

- 1 LEFT FLEX SHANK ASSEMBLY WITH 31-198 SHANK.
- 2 RIGHT FLEX SHANK ASSEMBLY WITH 31-197 SHANK.
- 3 FLEX SHANK ASSEMBLY WITH 31-196 SHANK.

REV. 3/00
M4990-1

MODELS 4995-28N & 4995-28NR WITH 22" DISC BLADES

9/99

TIE RODS		DISC BLADES -- 4995-28N		DISC BLADES -- 4995-28NR			
LOCATION	QTY. DISC	SPACING	TIE ROD NUMBER	LENGTH	PART NUMBER	DIAMETER	QTY.
Center Front	10	8"	4995-0-6	78-1/2"	30-223	22"	78
Center Rear	9	8"	4995-0-5	70-1/2"	30-225	20"	4
Wing Front	11	8"	1541-20-1	86-1/2"	30-235	18"	2
Wing Rear Inside	6	8"	2430-18-1	46-1/2"	30-148	16" Cut Out	2
Wing Rear Outside	6	8"	2430-18-1	46-1/2"	30-100	16" Cut Out	2

SPRING LOADED SCRAPERS

RIGID SCRAPERS (5")



LOCATION	NUMBER SCRAPERS	SCRAPER ASSEMBLY	SCRAPER BAR	LENGTH	SCRAPER ASSEMBLY	SCRAPER BAR	LENGTH
Left Front Center	10	2008-100-0A	2008-1-795	79-1/2"	* 4908-100-0A	2008-1-795	79-1/2"
Right Front Center	10	2008-100-0B	2008-1-795	79-1/2"	* 4908-100-0B	2008-1-795	79-1/2"
Left Rear Center	8	* 2008-080-0B	2008-1-625	62-1/2"	4908-080-0B	2008-1-625	62-1/2"
Right Rear Center	8	* 2008-080-0A	2008-1-625	62-1/2"	4908-080-0A	2008-1-625	62-1/2"
Left Front Wing	10	2008-100-0A	2008-1-795	79-1/2"	* 4908-100-0A	2008-1-795	79-1/2"
Right Front Wing	10	2008-100-0B	2008-1-795	79-1/2"	* 4908-100-0B	2008-1-795	79-1/2"
Left Rear Wing	12 + EXT.	* 2008-121-0B	2008-1-104	104"	4908-121-0B	2008-1-104	104"
Right Rear Wing	12 + EXT.	* 2008-121-0A	2008-1-104	104"	4908-121-0A	2008-1-104	104"

* COMBINATION SCRAPERS (5" Rigid Scrapers on FRONT, Spring Scrapers on REAR)

MODELS 4995-28W AND 4995-28WR

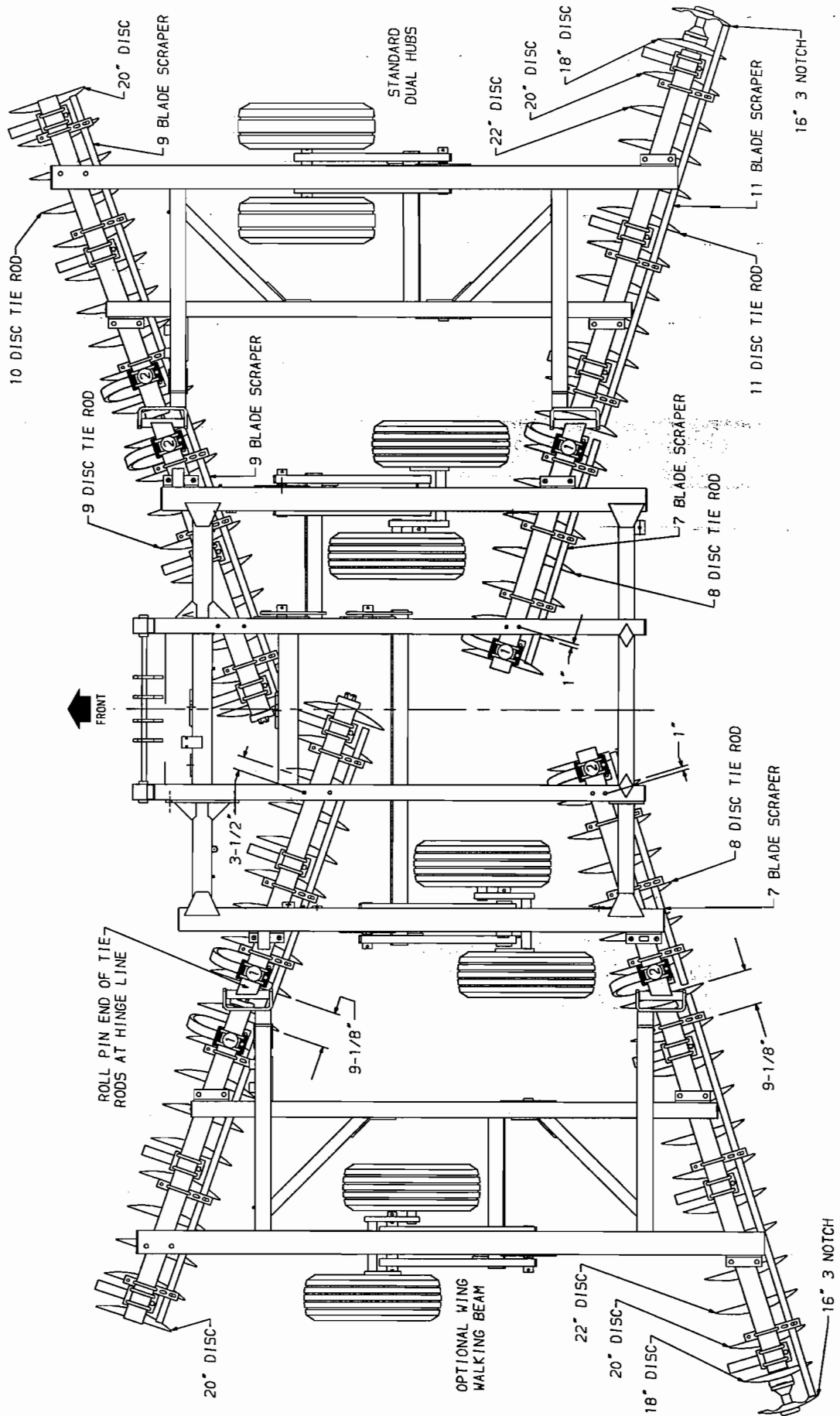
22" BLADES 9-1/8" SPACING



-  LEFT FLEX SHANK ASSEMBLY WITH 31-198 SHANK.
-  RIGHT FLEX SHANK ASSEMBLY WITH 31-197 SHANK.
-  FLEX SHANK ASSEMBLY WITH 31-196 SHANK.

REV. 3/00
M4990-2

MODELS 4995-28W & 4995-28WR WITH 22" DISC BLADES

9/99

TIE RODS		DISC BLADES -- 4995-28W			DISC BLADES -- 4995-28WR		
LOCATION	QTY. DISC	SPACING	TIE ROD NUMBER	LENGTH	PART NUMBER	DIAMETER	QTY.
Center Front	9	9-1/8"	4995-0-7	79-1/2"	30-223	22"	70
Center Rear	8	9-1/8"	4995-0-5	70-1/2"	30-225	20"	4
Wing Front	10	9-1/8"	4995-0-8	88-5/8"	30-235	18"	2
Wing Rear	11	9-1/8"	4995-0-9	97-7/8"	30-148	16" Cut Out	2

SPRING LOADED SCRAPER

RIGID SCRAPER (5")



LOCATION	NUMBER SCRAPER	SCRAPER ASSEMBLY	SCRAPER BAR	LENGTH	SCRAPER ASSEMBLY	SCRAPER BAR	LENGTH
Left Front Center	9	2009-090-0A	2008-1-795	79-1/2"	* 4907-185-0	2008-1-795	79-1/2"
Right Front Center	9	2009-090-0B	2008-1-795	79-1/2"	* 4907-186-0	2008-1-795	79-1/2"
Left Rear Center	7	* 2009-070-0B	2008-1-625	62-1/2"	4901-179-0	2008-1-625	62-1/2"
Right Rear Center	7	* 2009-070-0A	2008-1-625	62-1/2"	4901-180-0	2008-1-625	62-1/2"
Left Front Wing	9	2008-090-0A	2008-1-795	79-1/2"	* 4907-185-0	2008-1-795	79-1/2"
Right Front Wing	9	2009-090-0B	2008-1-795	79-1/2"	* 4907-186-0	2008-1-795	79-1/2"
Left Rear Wing	11 + EXT.	* 2009-111-0B	2008-1-104	104"	4907-183-0	2008-1-104	104"
Right Rear Wing	11 + EXT.	* 2009-111-0A	2008-1-104	104"	4907-184-0	2008-1-104	104"

* COMBINATION SCRAPER (5" Rigid Scrapers on FRONT, Spring Scrapers on REAR)

MODELS 4995-28W AND 4995-28WR

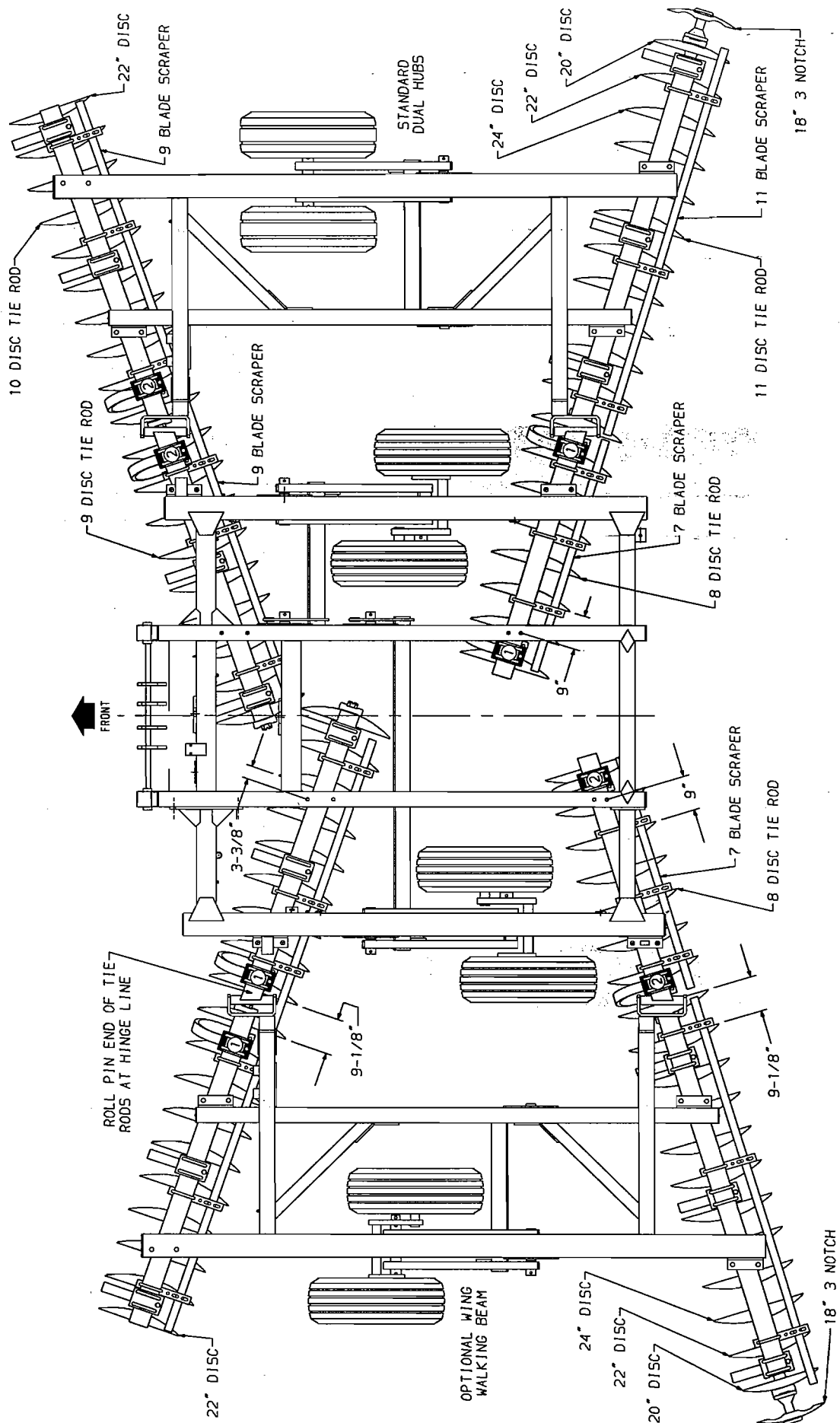
24" BLADES 9-1/8" SPACING



-  LEFT FLEX SHANK ASSEMBLY WITH 31-198 SHANK.
-  RIGHT FLEX SHANK ASSEMBLY WITH 31-197 SHANK.
-  FLEX SHANK ASSEMBLY WITH 31-196 SHANK.

REV. 3/00
M4995D-3

MODELS 4995-28W & 4995-28WR WITH 24" DISC BLADES

9/99

TIE RODS				DISC BLADES -- 4995-28W				DISC BLADES -- 4995-28WR			
LOCATION	QTY. DISC	SPACING	TIE ROD NUMBER	BLADE SIZE	LENGTH	PART NUMBER	DIAMETER	QTY.	PART NUMBER	DIAMETER	QTY.
Center Front	9	9-1/8"	4995-0-7	24"	79-1/2"	30-219	24"	70	30-220	24"	70
Center Rear	8	9-1/8"	4995-0-5	24"	70-1/2"	30-223	22"	4	30-241	22"	4
Wing Front	10	9-1/8"	4995-0-8	24"	88-5/8"	30-225	20"	2	30-225	20"	2
Wing Rear	11	9-1/8"	4995-0-9	24"	97-7/8"	30-147	18" Cut Out	2	30-102	18"	2

SPRING LOADED SCRAPERS

RIGID SCRAPERS (5")



LOCATION	NUMBER SCRAPERS	SCRAPER ASSEMBLY		SCRAPER BAR	LENGTH
		SCRAPER ASSEMBLY	SCRAPER BAR		
Left Front Center	9	2009-090-0A	2008-1-795	2008-1-795	79-1/2"
Right Front Center	9	2009-090-0B	2008-1-795	2008-1-795	79-1/2"
Left Rear Center	7	*2009-070-0B	2008-1-625	2008-1-625	62-1/2"
Right Rear Center	7	*2009-070-0A	2008-1-625	2008-1-625	62-1/2"
Left Front Wing	9	2008-090-0A	2008-1-795	2008-1-795	79-1/2"
Right Front Wing	9	2009-090-0B	2008-1-795	2008-1-795	79-1/2"
Left Rear Wing	11 + EXT.	*2009-111-0B	2008-1-104	2008-1-104	104"
Right Rear Wing	11 + EXT.	*2009-111-0A	2008-1-104	2008-1-104	104"

* COMBINATION SCRAPERS (5" Rigid Scrapers on FRONT, Spring Scrapers on REAR)

MODELS 4995-31N AND 4995-31NR

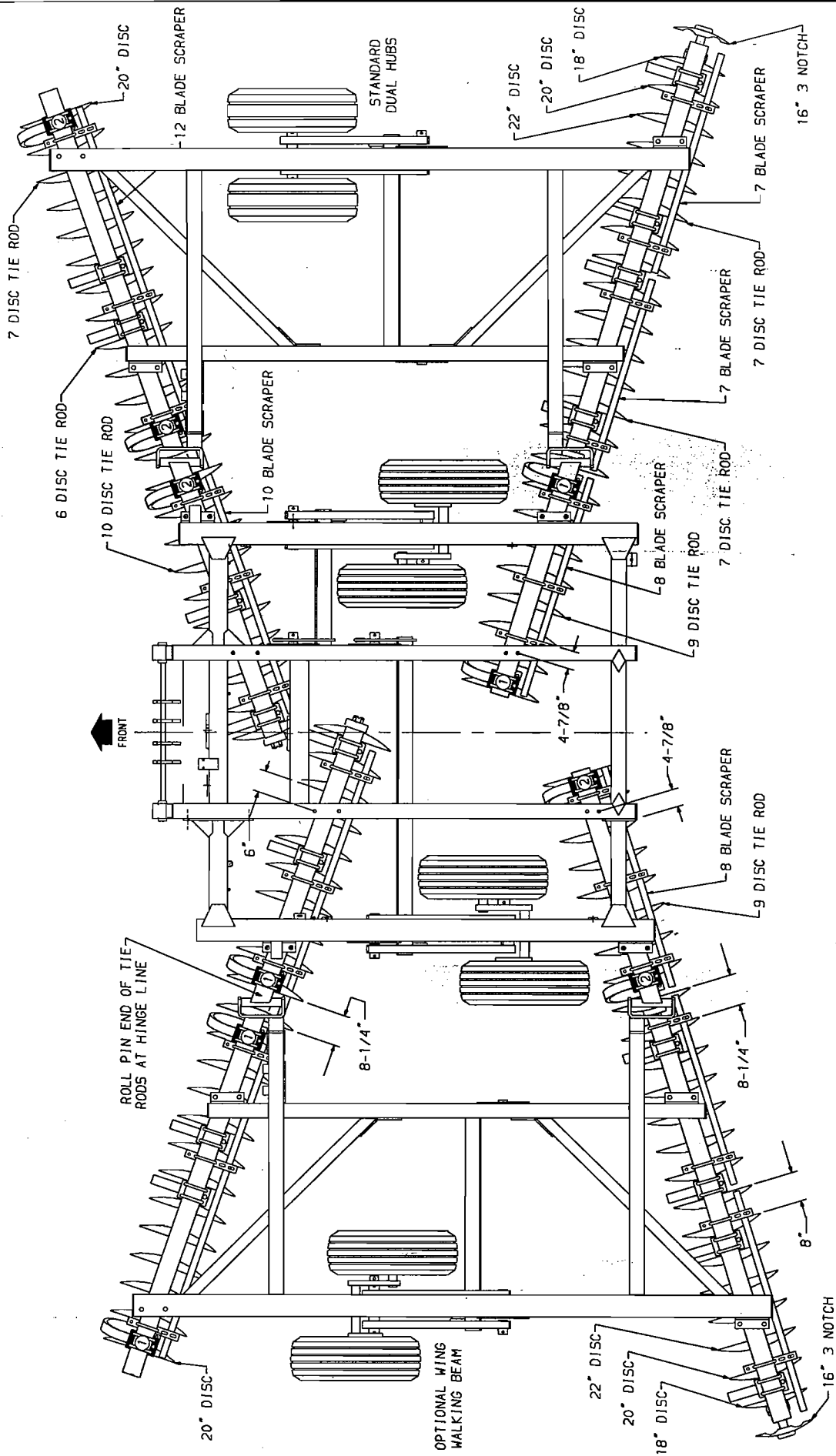
22" BLADES 8" SPACING



- 
LEFT FLEX SHANK ASSEMBLY WITH 31-198 SHANK.
- 
RIGHT FLEX SHANK ASSEMBLY WITH 31-197 SHANK.
- 
FLEX SHANK ASSEMBLY WITH 31-196 SHANK.

REV. 3/00
M4990-4

MODELS 4995-31N & 4995-31NR WITH 22" DISC BLADES

9/99

TIE RODS	QTY. DISC	SPACING	TIE ROD NUMBER	LENGTH	BLADE SIZE	DISC BLADES -- 4995-31N	DISC BLADES -- 4995-31-NR
LOCATION						PART NUMBER	PART NUMBER
						DIAMETER	DIAMETER
						QTY.	QTY.
Center Front	10	8"	4995-0-6	78-1/2"	22"	30-223	30-241
Center Rear	9	8"	4995-0-5	70-1/2"	22"	30-225	30-225
Wing Front Inside	6	8"	2430-18-1	46-1/2"	22"	30-235	30-235
Wing Front Outside	7	8"	4995-0-2	54-5/8"	22"	30-148	30-100
Wing Rear Inside	7	8"	4995-0-2	54-5/8"	22"	16" Cut Out	16" Cut Out
Wing Rear Outside	7	8"	4995-0-2	54-5/8"	22"		

SPRING LOADED SCRAPERS

RIGID SCRAPERS (5")

LOCATION	NUMBER SCRAPERS	SCRAPER ASSEMBLY	SCRAPER BAR	LENGTH	SCRAPER ASSEMBLY	SCRAPER BAR	LENGTH
Left Front Center	10	2008-100-0A	2008-1-795	79-1/2"	* 4908-100-0A	2008-1-795	79-1/2"
Right Front Center	10	2008-100-0B	2008-1-795	79-1/2"	* 4908-100-0B	2008-1-795	79-1/2"
Left Rear Center	8	* 2008-080-0B	2008-1-625	62-1/2"	4908-080-0B	2008-1-625	62-1/2"
Right Rear Center	8	* 2008-080-0A	2008-1-625	62-1/2"	4908-080-0A	2008-1-625	62-1/2"
Left Front Wing	12	2008-120-0A	2008-1-945	94-1/2"	* 4908-120-0A	2008-1-945	94-1/2"
Right Front Wing	12	2008-120-0B	2008-1-945	94-1/2"	* 4908-120-0B	2008-1-945	94-1/2"
L.R. Inside Wing	7	* 2008-070-0B	2008-1-535	53-1/2"	4908-070-0B	2008-1-535	53-1/2"
L.R. Outside Wing 7 + EXT.		* 2008-071-0B	2008-1-625	62-1/2"	4908-071-0B	2008-1-625	62-1/2"
R.R. Inside Wing	7	* 2008-070-0A	2008-1-535	53-1/2"	4908-070-0A	2008-1-535	53-1/2"
R. R. Outside Wing 7 + EXT.		* 2008-071-0A	2008-1-625	62-1/2"	4908-071-0A	2008-1-625	62-1/2"

* COMBINATION SCRAPERS (5" Rigid Scrapers on FRONT, Spring Scrapers on REAR)

MODELS 4995-31W AND 4995-31WR

22" BLADES 9-1/8" SPACING

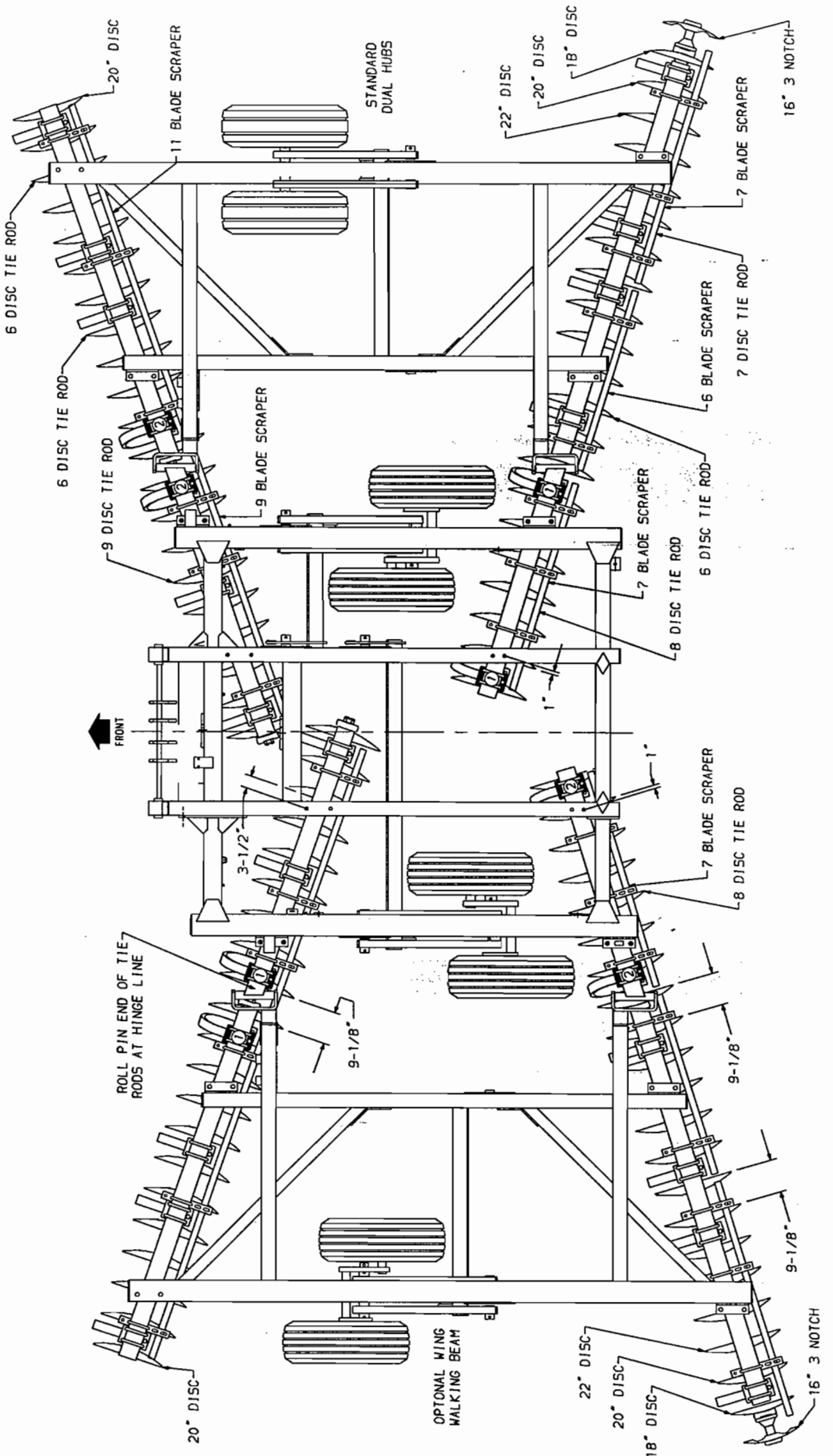

-  LEFT FLEX SHANK ASSEMBLY WITH 31-198 SHANK.
-  RIGHT FLEX SHANK ASSEMBLY WITH 31-197 SHANK.
-  FLEX SHANK ASSEMBLY WITH 31-196 SHANK.

REV. 3/00
M4990-5

MODELS 4995-31W & 4995-31WR WITH 22" DISC BLADES

9/99

TIE RODS

LOCATION	QTY. DISC	SPACING	TIE ROD NUMBER	LENGTH	BLADE SIZE	DISC BLADES -- 4995-31W	DISC BLADES -- 4995-31WR
						PART NUMBER	PART NUMBER
Center Front	9	9-1/8"	4995-0-7	79-1/2"	22"	30-223	30-241
Center Rear	8	9-1/8"	4995-0-5	70-1/2"	22"	30-225	30-225
Wing Front Inside	6	9-1/8"	4995-0-1	52-1/8"	22"	30-235	30-235
Wing Front Outside	6	9-1/8"	4995-0-1	52-1/8"	22"	30-148	30-100
Wing Rear Inside	6	9-1/8"	4995-0-1	52-1/8"	22"		16" Cut Out
Wing Rear Outside	7	9-1/8"	4995-0-3	61-3/8"	22"		16" Cut Out

SPRING LOADED SCRAPERS

LOCATION	NUMBER SCRAPERS	SCRAPER ASSEMBLY	SCRAPER BAR	LENGTH	SCRAPER ASSEMBLY	SCRAPER BAR	LENGTH
Left Front Center	9	2009-090-0A	2008-1-795	79-1/2"	* 4907-185-0	2008-1-795	79-1/2"
Right Front Center	9	2009-090-0B	2008-1-795	79-1/2"	* 4907-186-0	2008-1-795	79-1/2"
Left Rear Center	7	* 2009-070-0B	2008-1-625	62-1/2"	4901-179-0	2008-1-625	62-1/2"
Right Rear Center	7	* 2009-070-0A	2008-1-625	62-1/2"	4901-180-0	2008-1-625	62-1/2"
Left Front Wing	11	2009-110-0A	2008-1-975	97-1/2"	* 4907-180-0	2008-1-975	97-1/2"
Right Front Wing	11	2009-110-0B	2008-1-975	97-1/2"	* 4907-179-0	2008-1-975	97-1/2"
L.R. Inside Wing	6	* 2009-060-0B	2008-1-535	53-1/2"	4970-179-0	2008-1-535	53-1/2"
L.R. Outside Wing	7 + EXT.	* 2008-071-0B	2008-1-68	68"	4907-181-0	2008-1-68	68"
R.R. Inside Wing	6	* 2009-060-0A	2008-1-535	53-1/2"	4970-180-0	2008-1-535	53-1/2"
R. R. Outside Wing	7 + EXT.	* 2008-071-0A	2008-1-68	68"	4970-182-0	2008-1-68	68"

* COMBINATION SCRAPERS (5" Rigid Scrapers on FRONT, Spring Scrapers on REAR)

MODELS 4995-34N & 4995-34NR WITH 22" DISC BLADES

9/99

TIE RODS		DISC BLADES -- 4995-34N		DISC BLADES -- 4995-34NR				
LOCATION	QTY.	TIE ROD NUMBER	BLADE SIZE	PART NUMBER	DIAMETER	PART NUMBER	DIAMETER	QTY.
Center Front	10	4995-0-6	24"	30-223	22"	30-241	22"	98
Center Rear	9	4995-0-5	24"	30-225	20"	30-225	20"	4
Wing Front Inside	8	4995-0-4	24"	30-235	18"	30-235	18"	2
Wing Front Outside	8	4995-0-4	24"	30-148	16" Cut Out	30-100	16" Cut Out	2
Wing Rear Inside	9	4995-0-5	24"					
Wing Rear Outside	8	4995-0-4	24"					

SPRING LOADED SCRAPER

RIGID SCRAPER (5")

LOCATION	NUMBER SCRAPER	SCRAPER ASSEMBLY	SCRAPER BAR	LENGTH	SCRAPER ASSEMBLY	SCRAPER BAR	LENGTH
Left Front Center	10	2008-100-0A	2008-1-795	79-1/2"	* 4908-100-0A	2008-1-795	79-1/2"
Right Front Center	10	2008-100-0B	2008-1-795	79-1/2"	* 4908-100-0B	2008-1-795	79-1/2"
Left Rear Center	8	* 2008-080-0B	2008-1-625	62-1/5"	4908-080-0B	2008-1-625	62-1/2"
Right Rear Center	8	* 2008-080-0A	2008-1-625	62-1/2"	4908-080-0A	2008-1-625	62-1/2"
L.F. Inside Wing	8	2008-080-0A	2008-1-625	62-1/2"	* 4908-080-0A	2008-1-625	62-1/2"
L.F. Outside Wing	7	2008-070-0A	2008-1-535	53-1/2"	* 4908-070-0A	2008-1-535	53-1/2"
R.F. Inside Wing	8	2008-080-0B	2008-1-625	62-1/2"	* 4908-080-0B	2008-1-625	62-1/2"
R.F. Outside Wing	7	2008-070-0B	2008-1-535	53-1/2"	* 4908-070-0B	2008-1-535	53-1/2"
L.R. Inside Wing	9	* 2008-090-0B	2008-1-705	70-1/2"	4908-090-0B	2008-1-705	70-1/2"
L.R. Outside Wing	8 + EXT.	* 2008-081-0B	2008-1-705	70-1/2"	4908-081-0B	2008-1-705	70-1/2"
R.R. Inside Wing	9	* 2008-090-0A	2008-1-705	70-1/2"	4908-090-0A	2008-1-705	70-1/2"
R. R. Outside Wing	8 + EXT.	* 2008-081-0A	2008-1-705	70-1/2"	4908-081-0A	2008-1-705	70-1/2"

* COMBINATION SCRAPER (5" Rigid Scrapers on FRONT, Spring Scrapers on REAR)

MODELS 4995-34W & 4995-34WR WITH 22" DISC BLADES

9/99

TIE RODS		DISC BLADES -- 4995-34W		DISC BLADES -- 4995-34WR				
LOCATION	QTY. DISC	TIE ROD NUMBER	SPACING	BLADE LENGTH	BLADE SIZE	PART NUMBER	DIAMETER	QTY.
Center Front	9	4995-0-7	9-1/8"	79-1/2"	22"	30-223	22"	86
Center Rear	8	4995-0-5	9-1/8"	70-1/2"	22"	30-225	20"	4
Wing Front Inside	7	4995-0-3	9-1/8"	61-3/8"	22"	30-235	18"	2
Wing Front Outside	7	4995-0-3	9-1/8"	61-3/8"	22"	30-148	16" Cut Out	2
Wing Rear Inside	8	4995-0-5	9-1/8"	70-1/2"	22"			
Wing Rear Outside	7	4995-0-3	9-1/8"	61-3/8"	22"			

SPRING LOADED SCRAPER

LOCATION	NUMBER SCRAPER	SCRAPER ASSEMBLY	SCRAPER BAR	LENGTH
Left Front Center	9	2009-090-0A	2008-1-795	79-1/2"
Right Front Center	9	2009-090-0B	2008-1-795	79-1/2"
Left Rear Center	7	* 2009-070-0B	2008-1-625	62-1/2"
Right Rear Center	7	* 2009-070-0A	2008-1-625	62-1/2"
L.F. Inside Wing	7	2009-070-0A	2008-1-625	62-1/2"
L.F. Outside Wing	6	2009-060-0A	2008-1-535	53-1/2"
R.F. Inside Wing	7	2009-070-0B	2008-1-625	62-1/2"
R.F. Outside Wing	6	2009-060-0B	2008-1-535	53-1/2"
L.R. Inside Wing	8	* 2009-080-0B	2008-1-705	70-1/2"
L.R. Outside Wing	7 + EXT.	* 2009-071-0B	2008-1-68	68"
R.R. Inside Wing	8	* 2009-080-0A	2008-1-705	70-1/2"
R. R. Outside Wing	7 + EXT.	* 2009-071-0A	2008-1-68	68"

RIGID SCRAPER (5")

LOCATION	NUMBER SCRAPER	SCRAPER ASSEMBLY	SCRAPER BAR	LENGTH
Left Front Center	9	* 4907-185-0	2008-1-795	79-1/2"
Right Front Center	9	* 4907-186-0	2008-1-795	79-1/2"
Left Rear Center	7	4901-179-0	2008-1-625	62-1/2"
Right Rear Center	7	4901-180-0	2008-1-625	62-1/2"
L.F. Inside Wing	7	* 4901-180-0	2008-1-625	62-1/2"
L.F. Outside Wing	6	* 4970-180-0	2008-1-535	53-1/2"
R.F. Inside Wing	7	* 4901-179-0	2008-1-625	62-1/2"
R.F. Outside Wing	6	* 4970-179-0	2008-1-535	53-1/2"
L.R. Inside Wing	8	4906-186-0	2008-1-705	70-1/2"
L.R. Outside Wing	7 + EXT.	4907-181-0	2008-1-68	68"
R.R. Inside Wing	8	4906-185-0	2008-1-705	70-1/2"
R. R. Outside Wing	7 + EXT.	4907-182-0	2008-1-68	68"

* COMBINATION SCRAPER (5" Rigid Scrapers on FRONT, Spring Scrapers on REAR)

MODELS 4995-34W AND 4995-34WR

24" BLADES 9-1/8" SPACING

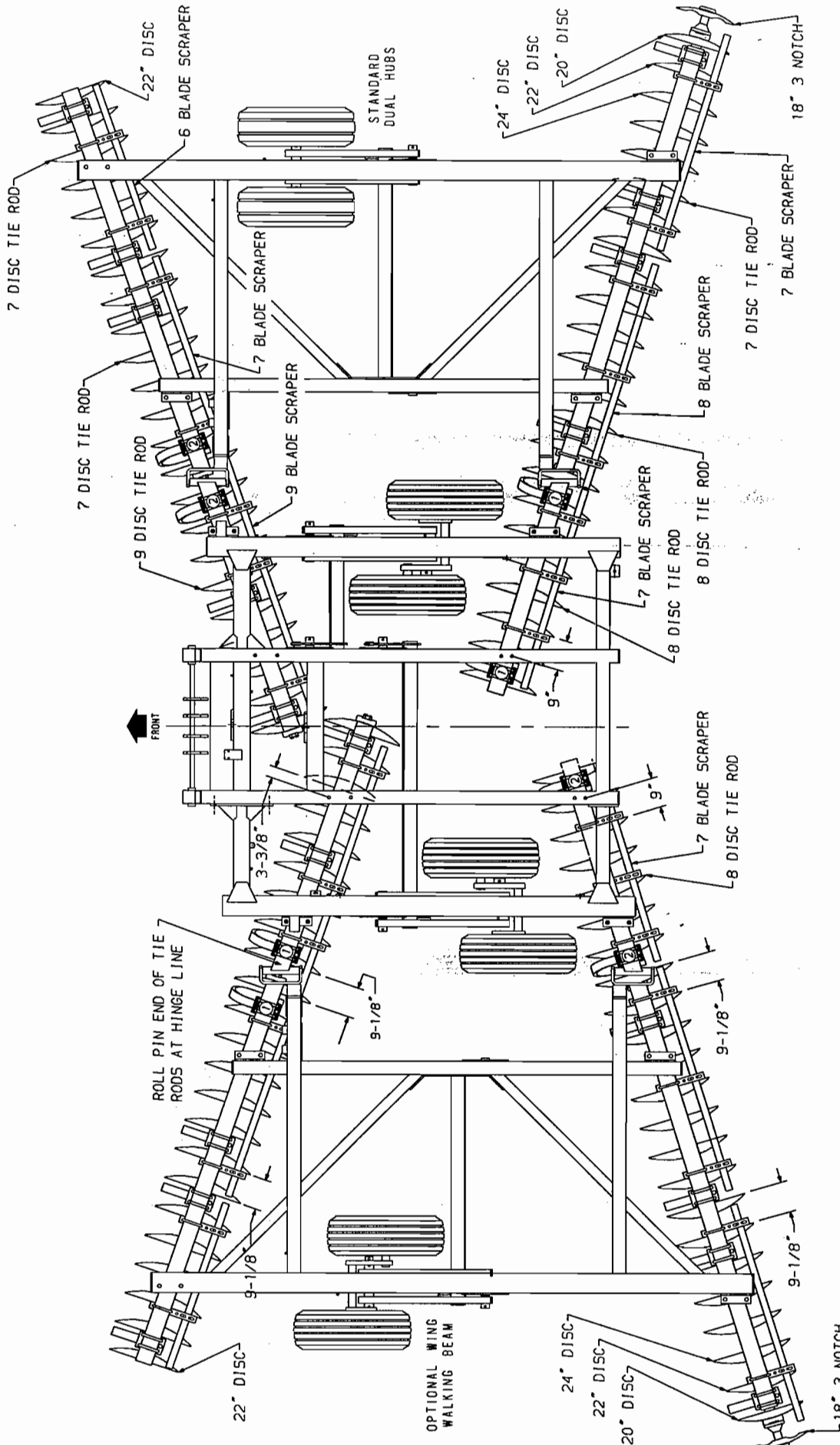

-  LEFT FLEX SHANK ASSEMBLY WITH 31-198 SHANK.
-  RIGHT FLEX SHANK ASSEMBLY WITH 31-197 SHANK.
-  FLEX SHANK ASSEMBLY WITH 31-196 SHANK.

REV. 3/00
M4990-9

MODELS 4995-34W & 4995-34WR WITH 24" DISC BLADES

9/99

TIE RODS		DISC BLADES -- 4995-34W		DISC BLADES -- 4995-34WR						
LOCATION	QTY.	DISC	SPACING	TIE ROD NUMBER	BLADE SIZE	PART NUMBER	DIAMETER	PART NUMBER	DIAMETER	QTY.
Center Front	9	9-1/8"	9-1/8"	4995-0-7	24"	30-219	24"	30-220	24"	86
Center Rear	8	9-1/8"	9-1/8"	4995-0-5	24"	30-223	22"	30-241	22"	4
Wing Front Inside	7	9-1/8"	9-1/8"	4995-0-3	24"	30-225	20"	30-225	20"	2
Wing Front Outside	7	9-1/8"	9-1/8"	4995-0-3	24"	30-147	18" Cut Out	30-102	18"	2
Wing Rear Inside	8	9-1/8"	9-1/8"	4995-0-5	24"					
Wing Rear Outside	7	9-1/8"	9-1/8"	4995-0-3	24"					

SPRING LOADED SCRAPER

LOCATION	NUMBER SCRAPER	SCRAPER ASSEMBLY	SCRAPER BAR	LENGTH
Left Front Center	9	2009-090-0A	2008-1-795	79-1/2"
Right Front Center	9	2009-090-0B	2008-1-795	79-1/2"
Left Rear Center	7	* 2009-070-0B	2008-1-625	62-1/2"
Right Rear Center	7	* 2009-070-0A	2008-1-625	62-1/2"
L.F. Inside Wing	7	2009-070-0A	2008-1-625	62-1/2"
L.F. Outside Wing	6	2009-060-0A	2008-1-535	53-1/2"
R.F. Inside Wing	7	2009-070-0B	2008-1-625	62-1/2"
R.F. Outside Wing	6	2009-060-0B	2008-1-535	53-1/2"
L.R. Inside Wing	8	* 2009-080-0B	2008-1-705	70-1/2"
L.R. Outside Wing	7 + EXT.	* 2009-071-0B	2008-1-68	68"
R.R. Inside Wing	8	* 2009-080-0A	2008-1-705	70-1/2"
R. R. Outside Wing	7 + EXT.	* 2009-071-0A	2008-1-68	68"

RIGID SCRAPER (5")

LOCATION	NUMBER SCRAPER	SCRAPER ASSEMBLY	SCRAPER BAR	LENGTH
Left Front Center	9	* 4907-185-0	2008-1-795	79-1/2"
Right Front Center	9	* 4907-186-0	2008-1-795	79-1/2"
Left Rear Center	7	4901-179-0	2008-1-625	62-1/2"
Right Rear Center	7	4901-180-0	2008-1-625	62-1/2"
L.F. Inside Wing	7	* 4901-180-0	2008-1-625	62-1/2"
L.F. Outside Wing	6	* 4970-180-0	2008-1-535	53-1/2"
R.F. Inside Wing	7	* 4901-179-0	2008-1-625	62-1/2"
R.F. Outside Wing	6	* 4970-179-0	2008-1-535	53-1/2"
L.R. Inside Wing	8	4906-186-0	2008-1-705	70-1/2"
L.R. Outside Wing	7 + EXT.	4907-181-0	2008-1-68	68"
R.R. Inside Wing	8	4906-185-0	2008-1-705	70-1/2"
R. R. Outside Wing	7 + EXT.	4907-182-0	2008-1-68	68"

* COMBINATION SCRAPER (5" Rigid Scrapers on FRONT, Spring Scrapers on REAR)

MODELS 4995-36W AND 4995-36WR

22" BLADES 9-1/8" SPACING

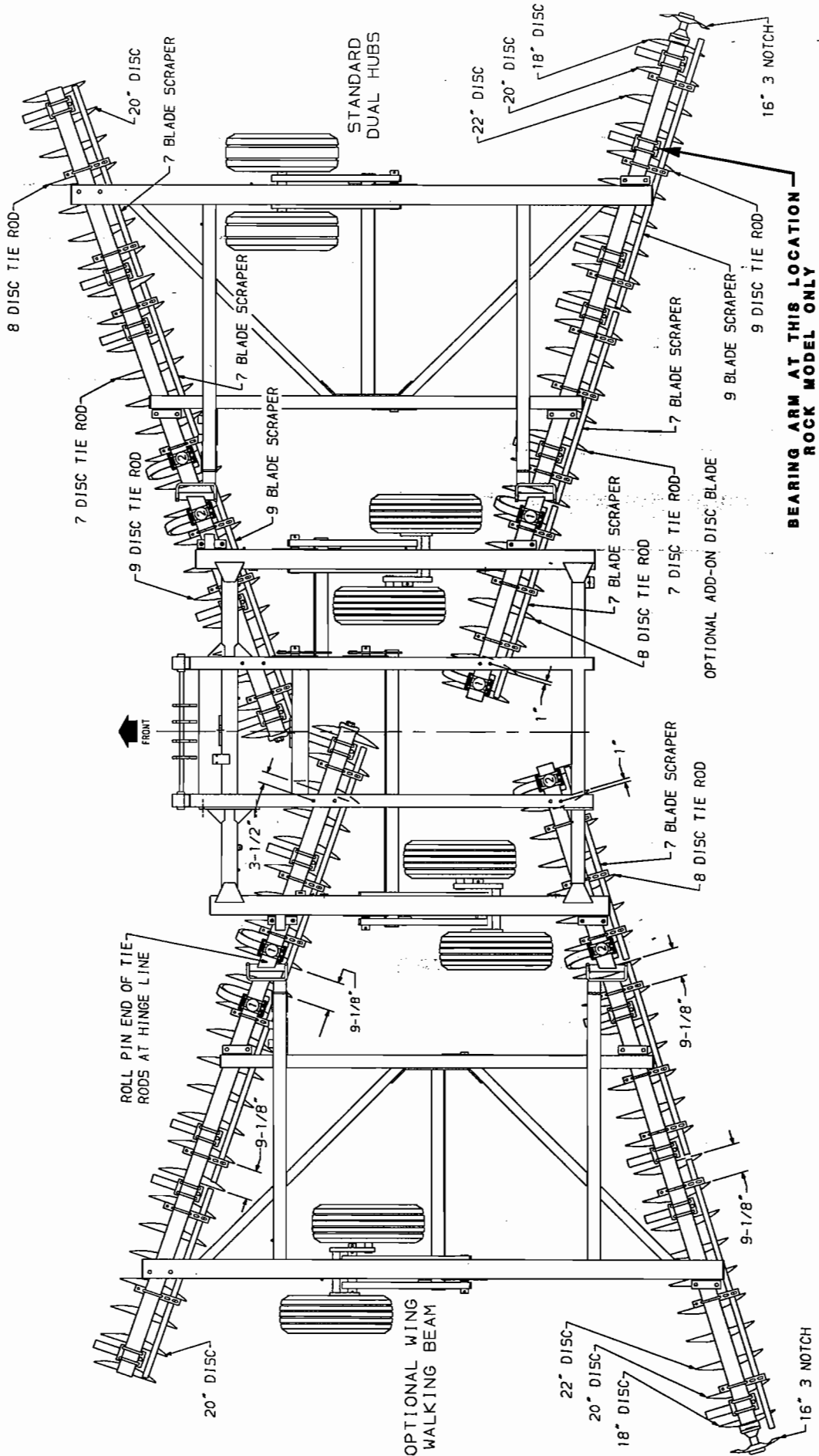

 LEFT FLEX SHANK ASSEMBLY WITH 31-198 SHANK.
 RIGHT FLEX SHANK ASSEMBLY WITH 31-197 SHANK.
 FLEX SHANK ASSEMBLY WITH 31-196 SHANK.
**BEARING ARM AT THIS LOCATION
ROCK MODEL ONLY**

REV. 3/00
M4990-110

MODELS 4995-36W & 4995-36WR WITH 22" DISC BLADES

9/99

TIE RODS	QTY.	DISC SPACING	TIE ROD NUMBER	BLADE LENGTH	BLADE SIZE	DISC BLADES -- 4995-36W	DISC BLADES -- 4995-36WR
LOCATION	DISC		NUMBER			PART NUMBER	PART NUMBER
						DIAMETER	DIAMETER
						QTY.	QTY.
Center Front	9	9-1/8"	4995-0-7	79-1/2"	22"	30-223	30-241
Center Rear	8	9-1/8"	4995-0-5	70-1/2"	22"	30-225	30-225
Wing Front Inside	7	9-1/8"	4995-0-3	61-3/8"	22"	30-235	30-235
Wing Front Outside	8	9-1/8"	4995-0-5	70-1/2"	22"	30-148	30-235
Wing Rear Inside	7	9-1/8"	4995-0-3	61-3/8"	22"		30-100
Wing Rear Outside	9	9-1/8"	4995-0-7	79-1/2"	22"		30-100

SPRING LOADED SCRAPER

LOCATION	NUMBER SCRAPER	SCRAPER ASSEMBLY	SCRAPER BAR	SCRAPER BAR	LENGTH
Left Front Center	9	2009-090-0A	2008-1-795	2008-1-795	79-1/2"
Right Front Center	9	2009-090-0B	2008-1-795	2008-1-795	79-1/2"
Left Rear Center	7	*2009-070-0B	2008-1-625	2008-1-625	62-1/2"
Right Rear Center	7	*2009-070-0A	2008-1-625	2008-1-625	62-1/2"
L.F. Inside Wing	7	2009-070-0A	2008-1-625	2008-1-625	62-1/2"
L.F. Outside Wing	7	2009-070-0A	2008-1-625	2008-1-625	62-1/2"
R.F. Inside Wing	7	2009-070-0B	2008-1-625	2008-1-625	62-1/2"
R.F. Outside Wing	7	2009-070-0B	2008-1-625	2008-1-625	62-1/2"
L.R. Inside Wing	7	*2009-070-0B	2008-1-625	2008-1-625	62-1/2"
L.R. Outside Wing	9 + EXT.	*2009-091-0B	2008-1-875	2008-1-875	87-1/2"
R.R. Inside Wing	7	*2009-070-0A	2008-1-625	2008-1-625	62-1/2"
R.R. Outside Wing	9 + EXT.	*2009-091-0A	2008-1-875	2008-1-875	87-1/2"

RIGID SCRAPER (5")

LOCATION	NUMBER SCRAPER	SCRAPER ASSEMBLY	SCRAPER BAR	SCRAPER BAR	LENGTH
Left Front Center	9	*4907-185-0	2008-1-795	2008-1-795	79-1/2"
Right Front Center	9	*4907-186-0	2008-1-795	2008-1-795	79-1/2"
Left Rear Center	7	4901-179-0	2008-1-625	2008-1-625	62-1/2"
Right Rear Center	7	4901-180-0	2008-1-625	2008-1-625	62-1/2"
L.F. Inside Wing	7	*4901-180-0	2008-1-625	2008-1-625	62-1/2"
L.F. Outside Wing	7	*4901-180-0	2008-1-625	2008-1-625	62-1/2"
R.F. Inside Wing	7	*4901-179-0	2008-1-625	2008-1-625	62-1/2"
R.F. Outside Wing	7	*4901-179-0	2008-1-625	2008-1-625	62-1/2"
L.R. Inside Wing	7	4901-179-0	2008-1-625	2008-1-625	62-1/2"
L.R. Outside Wing	9 + EXT.	4906-179-0	2008-1-875	2008-1-875	87-1/2"
R.R. Inside Wing	7	4901-180-0	2008-1-625	2008-1-625	62-1/2"
R.R. Outside Wing	9 + EXT.	4906-180-0	2008-1-875	2008-1-875	87-1/2"

* COMBINATION SCRAPER (5" Rigid Scrapers on FRONT, Spring Scrapers on REAR)

This page intentionally left blank.